





SiC Power Devices

CONTENTS

■ Schottky Barrier Diodes	P.232
■ SiC-MOSFET	P.235
■ Full SiC Power Modules	P.236

Schottky Barrier Diodes

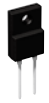
Quick Reference

V _{RM} (V)	I _F (A)	Leaded Type			
		 TO-220AC [2pin]	 TO-220FM [2pin]	 TO-247 [3pin]	 LPTL [4pin]
600	6	SCS106AG	SCS106AM		
	8	SCS108AG	SCS108AM		
	10	SCS110AG	SCS110AM		
	12	SCS112AG	SCS112AM		
	20	SCS120AG		SCS120AE2	
	40			SCS140AE2	
650	6	SCS206AG*	SCS206AM*		New SCS206AJ*
	8	SCS208AG*	SCS208AM*		New SCS208AJ*
	10	SCS210AG*	SCS210AM*		New SCS210AJ*
	12	SCS212AG*	SCS212AM*		New SCS212AJ*
	15	New SCS215AG*	New SCS215AM*		New SCS215AJ*
	20	SCS220AG*	New SCS220AM*	SCS220AE2*	New SCS220AJ*
	30			New SCS230AE2*	
	40			SCS240AE2*	
1,200	5	SCS205KG* SCS105KG			
	10	SCS210KG* SCS110KG		SCS210KE2* SCS110KE2	
	15	SCS215KG*			
	20	SCS220KG* SCS120KG		SCS220KE2* SCS120KE2	
	30			New SCS230KE2*	
	40			New SCS240KE2*	

*: 2nd Generation

2nd Generation low-V_F SiC-SBD

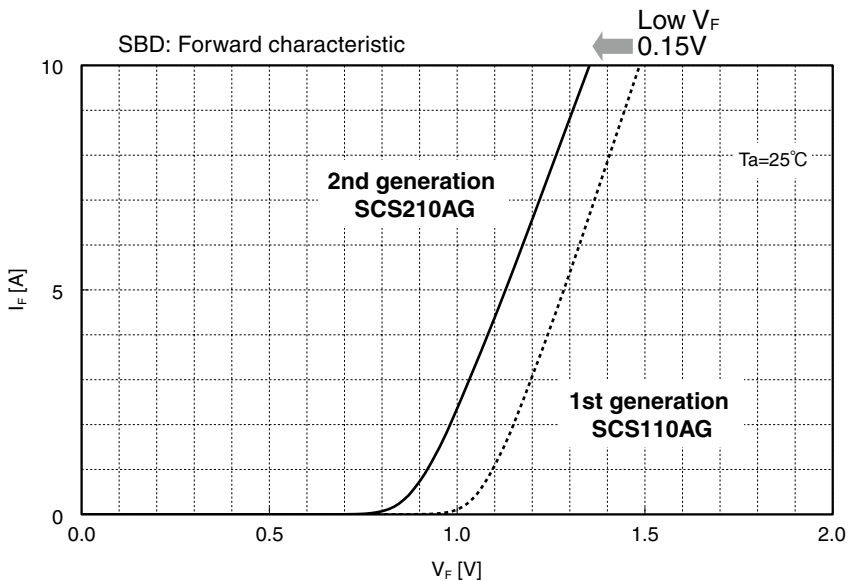

Product Lineup

• 2nd Generation (Low VF)

Part No.	Automotive Grade Available* ¹	Absolute Maximum Ratings (Ta=25°C)				Electrical Characteristics (Ta=25°C)				Package	Equivalent Circuit Diagram
		V _{RM} (V)	V _R (V)	I _F (A)	I _{FSM} (A) 60Hz.1	V _F (V) Typ.	I _F (A)	I _R (μA) Max.	V _R (V)		
New SCS206AJ	—	650	650	6	24	1.35	6	120	600	LPTL (4pin)	
New SCS208AJ	—	650	650	8	31	1.35	8	160	600		
New SCS210AJ	—	650	650	10	40	1.35	10	200	600		
New SCS212AJ	—	650	650	12	45	1.35	12	240	600		
New SCS215AJ	—	650	650	15	55	1.35	15	300	600		
New SCS220AJ	—	650	650	20	71	1.35	20	400	600		
SCS206AG	Yes	650	650	6	24	1.35	6	120	600	TO-220AC (2pin)	
SCS208AG	Yes	650	650	8	31	1.35	8	160	600		
SCS210AG	Yes	650	650	10	40	1.35	10	200	600		
SCS212AG	Yes	650	650	12	45	1.35	12	240	600		
New SCS215AG	Yes	650	650	15	55	1.35	15	300	600		
SCS220AG	Yes	650	650	20	71	1.35	20	400	600		
SCS206AM	—	650	650	6	24	1.35	6	120	600	TO-220FM (2pin)	
SCS208AM	—	650	650	8	31	1.35	8	160	600		
SCS210AM	—	650	650	10	40	1.35	10	200	600		
SCS212AM	—	650	650	12	45	1.35	12	240	600		
New SCS215AM	—	650	650	15	55	1.35	15	300	600		
New SCS220AM	—	650	650	20	71	1.35	20	400	600		
SCS220AE2	Yes	650	650	10/20* ²	40/80* ²	1.35	10	200	600	TO-247 (3pin)	
New SCS230AE2	—	650	650	15/30* ²	55/110* ²	1.35	15	300	600		
SCS240AE2	—	650	650	20/40* ²	71/140* ²	1.35	20	400	600		
SCS205KG	Yes	1,200	1,200	5	23	1.4	5	100	1,200	TO-220AC (2pin)	
SCS210KG	Yes	1,200	1,200	10	45	1.4	10	200	1,200		
SCS215KG	—	1,200	1,200	15	65	1.4	15	300	1,200		
SCS220KG	—	1,200	1,200	20	82	1.4	20	400	1,200		
SCS210KE2	—	1,200	1,200	5/10* ²	23/46* ²	1.4	5	100	1,200	TO-247 (3pin)	
SCS220KE2	—	1,200	1,200	10/20* ²	44/88* ²	1.4	10	200	1,200		
New SCS230KE2	—	1,200	1,200	15/30* ²	65/130* ²	1.4	15	300	1,200		
New SCS240KE2	—	1,200	1,200	20/40* ²	84/160* ²	1.4	20	400	1,200		

*¹ As of June, 2013.*² (Per Leg / Device)

• 1st Generation

Part No.	Automotive Grade Available	Absolute Maximum Ratings (Ta=25°C)				Electrical Characteristics (Ta=25°C)				Package	Equivalent Circuit Diagram
		V _{RM} (V)	V _R (V)	I _F (A)	I _{FSM} (A) 60Hz.1	V _F (V) Typ.	I _F (A)	I _R (μA) Max.	V _R (V)		
SCS106AG	—	600	600	6	21	1.5	6	120	600	TO-220AC (2pin)	
SCS108AG	—	600	600	8	29	1.5	8	160	600		
SCS110AG	—	600	600	10	40	1.5	10	200	600		
SCS112AG	—	600	600	12	41	1.5	12	240	600		
SCS120AG	—	600	600	20	76	1.5	20	400	600		
SCS106AM	—	600	600	6	21	1.5	6	120	600		
SCS108AM	—	600	600	8	29	1.5	8	160	600	TO-220FM (2pin)	
SCS110AM	—	600	600	10	40	1.5	10	200	600		
SCS112AM	—	600	600	12	41	1.5	12	240	600		
SCS120AE2	—	600	600	10/20*	40/80*	1.5	10	200	600	TO-247 (3pin)	
SCS140AE2	—	600	600	20/40*	76/152*	1.5	20	400	600		
SCS105KG	—	1,200	1,200	5	21	1.5	5	100	1,200	TO-220AC (2pin)	
SCS110KG	—	1,200	1,200	10	45	1.5	10	200	1,200		
SCS120KG	—	1,200	1,200	20	84	1.5	20	400	1,200		
SCS110KE2	—	1,200	1,200	5/10*	20/40*	1.5	5	100	1,200	TO-247 (3pin)	
SCS120KE2	—	1,200	1,200	10/20*	40/80*	1.5	10	200	1,200		

* (Per Leg / Device)

Schottky Barrier Diodes

■ Dimensions (Unit : mm)

• Leded Type

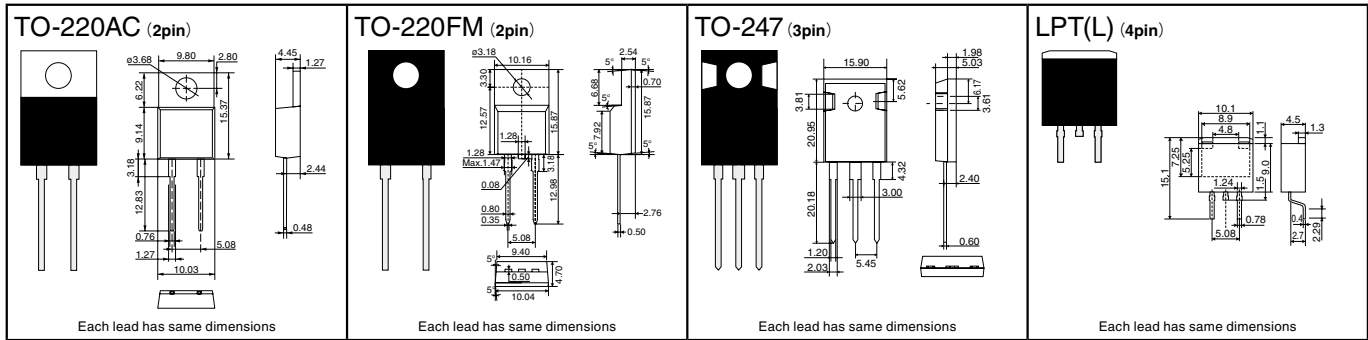

■ Part No. Explanation

• Schottky Barrier Diode Part No. Explanation

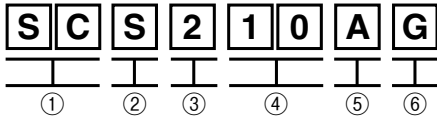

- ① SiC
- ② SBD
- ③ Generation
- ④ Current [A]
Example 05 → 5A
10 → 10A

- ⑤ Voltage
Example A → 600V/650V
K → 1200V
- ⑥ Package
Example E → TO-247(3pin)
G → TO-220AC (2pin)
M → TO-220FM (2pin)
J → LPT(L) (4pin)

SiC-MOSFET

Quick Reference

V _{DSS} (V)	R _{DS(ON)} (mΩ)	Leaded Type		SiC SBD
		TO-220AB (3pin)	TO-247 (3pin)	
400	120	New SCTMU001F		-
650	120	New SCT2120AF		-
1,200	80		SCH2080KE	Co-packed
	160		SCT2080KE	-
	280		New SCT2160KE	-
	450		New SCT2280KE	-
			New SCT2450KE	-

Product Lineup

•SWITCHING SERIES

Part No.	Polarity (ch)	V _{DSS} (V)	I _D (A)	P _D (W) (T _c = 25°C)	R _{DS(on)} Typ. (mΩ)	Q _g Typ. (nC)		Package
					V _{GS} = 18V	V _{GS} = 18V	Drive Voltage (V)	
New SCT2120AF [No avalanche guarantee]	N	650	29	165	120	61	18	TO-220AB
SCH2080KE [No avalanche guarantee]	N	1,200	35	179	80	106	18	TO-247
SCT2080KE [No avalanche guarantee]	N	1,200	35	179	80	106	18	
New SCT2160KE [No avalanche guarantee]	N	1,200	22	165	160	62	18	
New SCT2280KE [No avalanche guarantee]	N	1,200	14	108	280	36	18	
New SCT2450KE [No avalanche guarantee]	N	1,200	10	85	450	27	18	

•MUSIC SERIES

Part No.	Polarity (ch)	V _{DSS} (V)	I _D (A)	P _D (W) (T _c = 25°C)	R _{DS(on)} Typ. (mΩ)	Q _g Typ. (nC)		Package
					V _{GS} = 18V	V _{GS} = 18V	Drive Voltage (V)	
New SCTMU001F [No avalanche guarantee]	N	400	20	132	120	59	18	TO-220AB

Dimensions (Unit : mm)

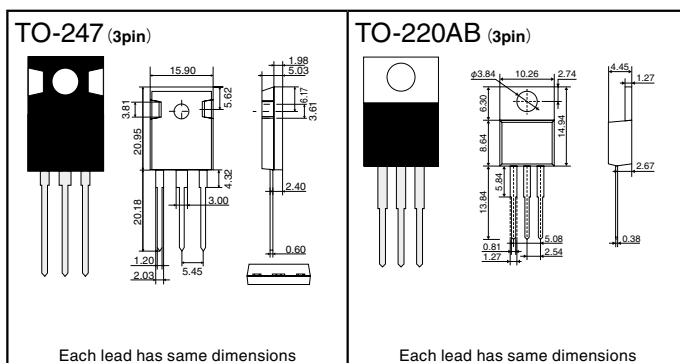

Internal circuit

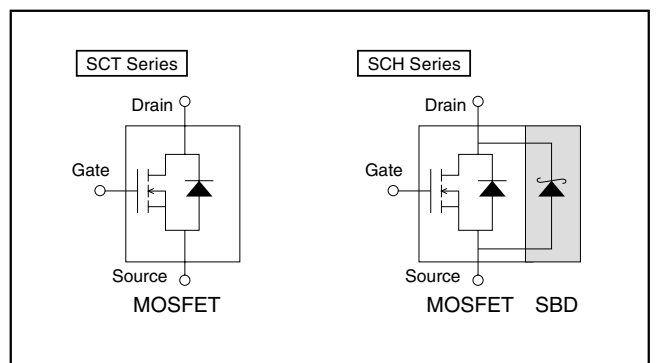

Part No. Explanation

•MOSFET Part No. Explanation

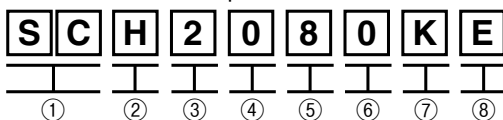

- ① SiC
- ② H → MOSFET+SBD
T → MOSFET
- ③ Generation
- ④
- ⑤ } ON-resistance [mΩ]
- ⑥ }
- ⑦ Voltage A → 650V K → 1200V
- ⑧ Package E → TO-247
F → TO-220AB (3pin)

Full SiC Power Modules

Quick Reference

V _{DSS} (V)	R _{DS(ON)} (mΩ)	Case Type
		
1,200	22	BSM120D12P2C005
	12.8	New BSM180D12P2C101

Product Lineup

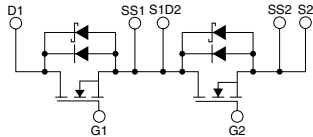
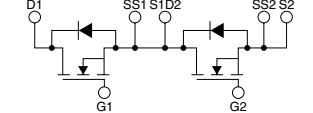
Part No.	Absolute Maximum Ratings (Ta=25°C)						Internal circuit
	V _{DS} (V)	V _{GS} (V)	I _D (A) (Tc=60°C)	T _J (°C)	T _{stg} (°C)	Visol (V) AC 1min.	
BSM120D12P2C005	1,200	-6 to +22	120	-40 to +150	-40 to +125	2,500	
New BSM180D12P2C101	1,200	-6 to +22	180	-40 to +150	-40 to +125	2,500	

Dimensions

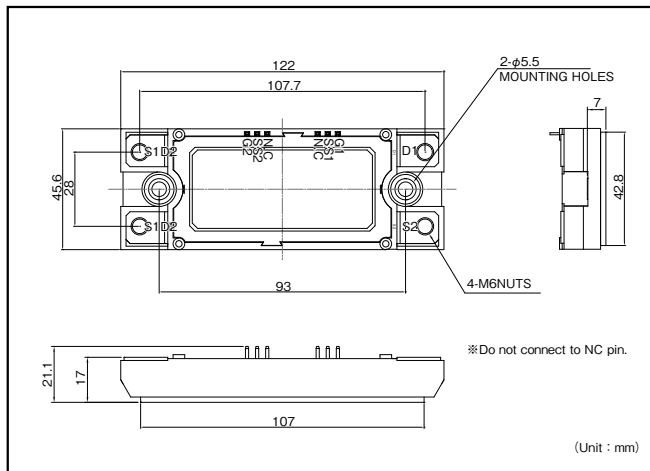

Feature

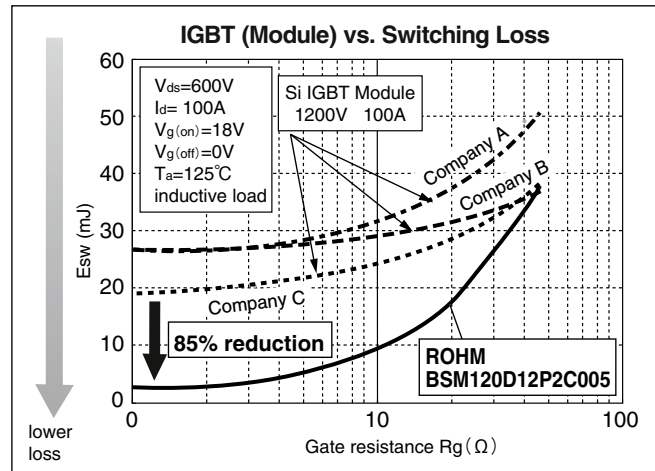

Part No. Explanation

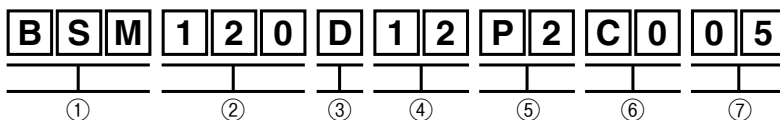

- ① SiC Power Module
- ② Rated Current
- ③ 2 in 1
- ④ Breakdown Voltage
Example 12 → 1200V
- ⑤ Device Type
- ⑥ Case Type
- ⑦ Additional Number

Packaging type

Package	Code	Packaging style	Basic ordering unit (pcs)
TO-220AC/AB	C	Tube	50
TO-220FM	C	Tube	50
TO-247	C	Tube	30
LPT(L)	TLL	Embossed Tape	1000

Notes

- 1) The information contained in this document is provided as of 1st. October, 2013.
- 2) The information contained herein is subject to change without notice. Before you use our Products, please contact our sales representative (as listed below) and verify the latest specifications.
- 3) Although ROHM is continuously working to improve product reliability and quality, semiconductors can break down and malfunction due to various factors. Therefore, in order to prevent personal injury or fire arising from failure, please take safety measures such as complying with the derating characteristics, implementing redundant and fire prevention designs, and utilizing backups and fail-safe procedures. ROHM shall have no responsibility for any damages arising out of the use of our Products beyond the rating specified by ROHM.
- 4) Examples of application circuits, circuit constants and any other information contained herein are provided only to illustrate the standard usage and operations of the Products. The peripheral conditions must be taken into account when designing circuits for mass production.
- 5) The technical information specified herein is intended only to show the typical functions of and examples of application circuits for the Products. ROHM does not grant you, explicitly or implicitly, any license to use or exercise intellectual property or other rights held by ROHM or any other parties. ROHM shall have no responsibility whatsoever for any dispute arising out of the use of such technical information.
- 6) The Products are intended for use in general electronic equipment (i.e. AV/OA devices, communication, consumer systems, gaming/entertainment sets) as well as the applications indicated in this document.
- 7) The Products specified in this document are not designed to be radiation tolerant.
- 8) For use of our Products in applications requiring a high degree of reliability (as exemplified below), please contact and consult with a ROHM representative: transportation equipment (i.e. cars, ships, trains), primary communication equipment, traffic lights, fire/crime prevention, safety equipment, medical systems, servers, solar cells, and power transmission systems.
- 9) Do not use our Products in applications requiring extremely high reliability, such as aerospace equipment, nuclear power control systems, and submarine repeaters.
- 10) ROHM shall have no responsibility for any damages or injury arising from non-compliance with the recommended usage conditions and specifications contained herein.
- 11) ROHM has used reasonable care to ensure the accuracy of the information contained in this document. However, ROHM does not warrant that such information is error-free and ROHM shall have no responsibility for any damages arising from any inaccuracy or misprint of such information.
- 12) Please use the Products in accordance with any applicable environmental laws and regulations, such as the RoHS Directive. For more details, including RoHS compatibility, please contact a ROHM sales office as listed below. ROHM shall have no responsibility for any damages or losses resulting non-compliance with any applicable laws or regulations.
- 13) When providing our Products and technologies contained in this document to other countries, you must abide by the procedures and provisions stipulated in all applicable export laws and regulations, including without limitation the US Export Administration Regulations and the Foreign Exchange and Foreign Trade Act.
- 14) This document, in part or in whole, may not be reprinted or reproduced without prior consent of ROHM.

[Compliance to RoHS Directive]

All of the products comply with the RoHS Directive.
With the exception of specific exemptions granted under the RoHS Directive and naturally occurring impurities, the products conforms to control limits on the six substances regulated by the RoHS Directive (lead, cadmium, mercury, hexavalent chromium, PBB, and PBDE). Indicates that the product's terminals and electrodes contain no lead. The products internal components other than those specifically exempted under the RoHS Directive. It should not be construed as guarantee of compliance with laws and regulations enacted by EU member states in response to the RoHS Directive.

[Viewing the catalog]

■ **New** indicates new product.

■ ☆ indicates product under development.