

IS31FL3743A

18 × 11 DOTS MATRIX LED DRIVER

Advance Information
May 2018

GENERAL DESCRIPTION

The IS31FL3743A is a general purpose 18×n (n=1~11) LED Matrix programmed via 1MHz I2C compatible interface. Each LED can be dimmed individually with 8-bit PWM data and 8-bit DC scaling data which allowing 256 steps of linear PWM dimming and 256 steps of DC current adjustable level.

Additionally each LED open and short state can be detected, IS31FL3743A store the open or short information in Open-Short Registers. The Open-Short Registers allowing MCU to read out via I2C compatible interface, inform MCU whether there are LEDs open or short and the locations of open or short LEDs.

The IS31FL3743A operates from 2.7V to 5.5V and features a very low shutdown and operational current.

IS31FL3743A is available in UQFN-40 (5mm×5mm) package. It operates from 2.7V to 5.5V over the temperature range of -40°C to +125°C.

FEATURES

- Supply voltage range: 2.7V to 5.5V
- 18 current sinks
- Support 18×n (n=1~11) LED matrix configurations
- Individual 256 PWM control steps
- Individual 256 DC current steps
- Global 256 DC current steps
- SDB rising edge reset I2C module
- Programmable H/L logic: 1.4V/0.4V, 2.4V/0.6V
- 24kHz PWM frequency
- 1MHz I2C-compatible interface
- State lookup registers
- Individual open and short error detect function
- 180 degree phase delay operation to reduce power noise
- De-Ghost
- Cascade for synchronization of chips
- UQFN-40 (5mm×5mm) package

APPLICATIONS

- Mobile phones and other hand-held devices for LED display
- Gaming device (Keyboard, Mouse etc.)
- LED in white goods application

TYPICAL APPLICATION CIRCUIT

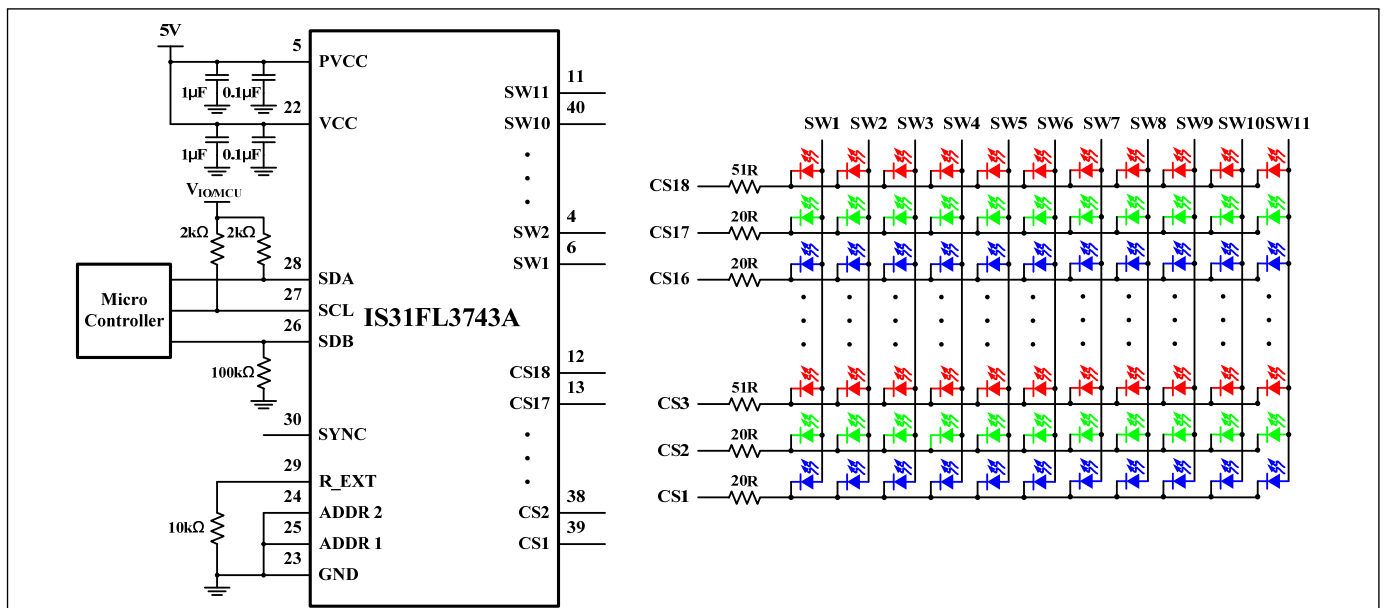

Figure 1 Typical Application Circuit: 66 RGBs

Note 1: For the mobile applications the IC should be placed far away from the mobile antenna in order to prevent the EMI.

Note 2: PVCC and VCC should use same power supply to avoid the additional I_{SD} , it is OK to use $PV_{CC}=V_{CC}=5V$ and $V_{IO}=3.3V$.

Note 3: The 20R and 50R between LED and IC is only for thermal reduction.

IS31FL3743A

TYPICAL APPLICATION CIRCUIT (CONTINUED)

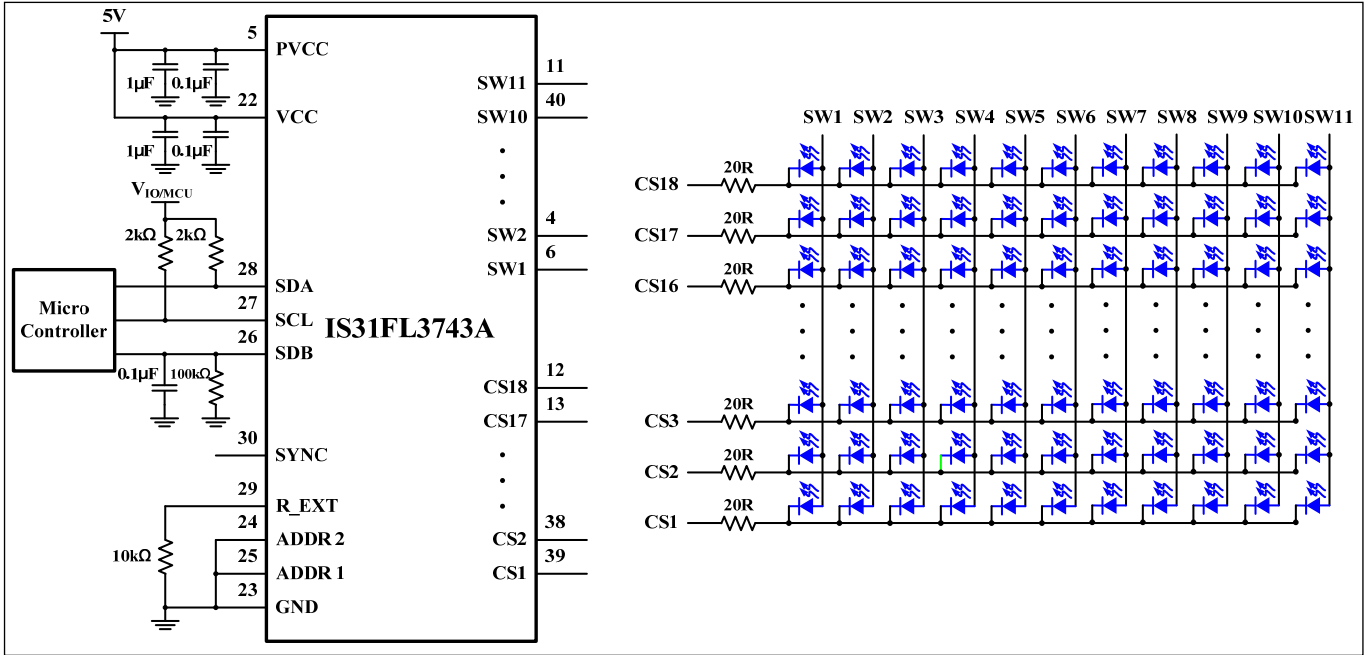

Figure 2 Typical Application Circuit: 198 mono color LEDs

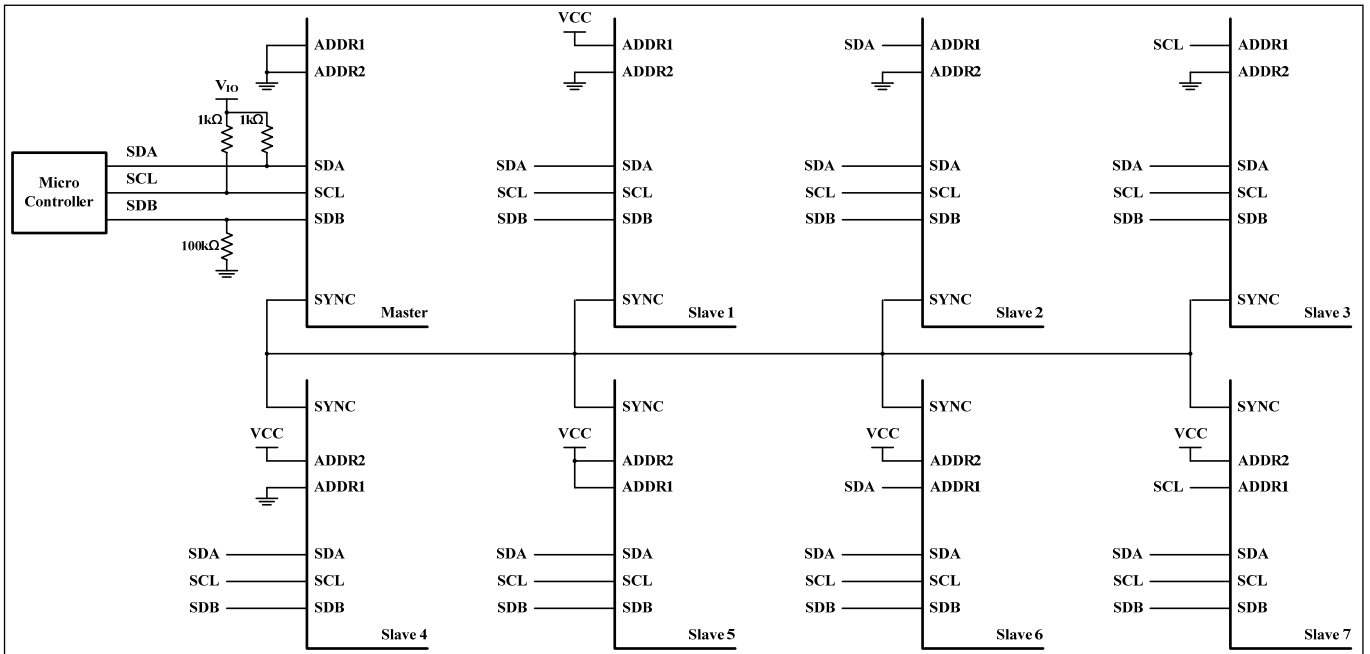

Figure 3 Typical Application Circuit (Eight Parts Synchronization-Work)

Note 4: One part is configured as master mode, all the other 7 parts configured as slave mode. Work as master mode or slave mode specified by Configuration Register (SYNC bits, register 25h, Page 2). Master part output master clock, and all the other parts which work as slave input this master clock.