

# THINKING ELECTRONIC INDUSTRIAL CO., LTD.

HEAD OFFICE: 8F-1, No.93, Ta-Shun 1st Rd., Kaohsiung, Taiwan  
 TEL: 886-7-5577660 FAX: 886-7-5570560

**MANUFACTURING SITE**

- KAOHSIUNG FACTORY: No.51, Kaifa Road, Nantze Export Processing Zone,  
Kaohsiung City 81170, Taiwan  
TEL: 886-7-9616668 FAX: 886-7-9616698
- CHANGZHOU FACTORY: No.6 Longmen Road, Wujin National High&New-Tech Industrial  
Development Zone, ChangZhou, JiangSu, China  
TEL: 86-519-86578999 FAX: 86-519-86558643
- DONG GUAN FACTORY: Chiao-Tou Tsun, Sha-Tao Hsiang, Chang-An Town,  
Dong-Guan City 523863, Guangdong, China  
TEL: 86-769-85542016 FAX: 86-769-85546890
- YICHANG FACTORY: No. 283 Xiaoting Avenue, Xiaoting Dist., Yichang  
City 443007, Hubei, China  
TEL: 86-717-6510010 FAX: 86-717-6511430



## SPECIFICATION FOR APPROVAL

<b>CUSTOMER</b>	_____
<b>CERTIFIED</b>	_____
<b>MODEL/TYPE</b>	TVR05431
<b>PART NO.</b>	TVR05431KFC3FY-H (RoHS)
<b>APPLICATION</b>	_____
<b>CUSTOMER P/N</b>	_____
<b>ISSUE DATE</b>	Jun.11.2019
<b>REV. NO</b>	_____
<b>REV. DATE</b>	_____

<b>FOR CUSTOMER APPROVAL</b>	<b>CHECKED BY</b>
	Yuan Yuan
	<b>APPROVED BY</b>
	Huaifang Zhang





**REVISED RECORD SHEET**

REV. NO	REV. DATE	REVISED CONTENT



<b>INDEX</b>	<b>Page</b>
■ <b>Part Number Code</b>	<b>1</b>
■ <b>Structure and Dimensions</b>	<b>2</b>
■ <b>Electrical Characteristics</b>	<b>2</b>
■ <b>Reliability</b>	<b>3 ~ 4</b>
■ <b>Soldering Recommendation</b>	<b>5</b>
■ <b>Power Derating Curve</b>	<b>6</b>
■ <b>RoHS Compliant Declaration</b>	<b>6</b>
■ <b>Warehouse Storage Conditions of Products</b>	<b>6</b>
■ <b>Safety Approvals</b>	<b>7</b>
■ <b>Certificates</b>	<b>7</b>
■ <b>Max. Surge Current Derating Curves</b>	<b>8</b>
■ <b>Max. Leakage Current and Max. Clamping Voltage Curve</b>	<b>9</b>

Part Number Code

Example :

**TVR**    **05**    **431**    **K**    **F**    **C3F**    **Y**    **-H**  
 (1)    (2)    (3)    (4)    (5)    (6)    (7)    (8)

No.	Item	Digit	Specification
(1)	Product Type	TVR	Thinking varistor TVR type
(2)	Body Size	05	φ 05 mm
(3)	Varistor Voltage	431	$43 \times 10^1 \text{ V} = 430\text{V} (V_{1\text{mA}})$
(4)	Tolerance of $V_{1\text{mA}}$	K	±10%
(5)	Appearance	F	Y Kink Lead, Epoxy Coating
(6)	Packaging	C3F	Cut 3.5 mm Lead & bulk
(7)	Optional Suffix	Y	RoHS compliance
(8)	Customer code	-H	Design Location Region

Structure and Dimensions

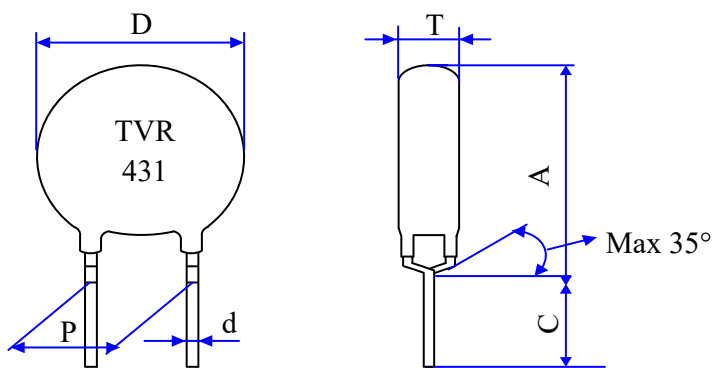

( unit : mm )

Body Size	D	P	d	A max.	C	T
φ 05	5.0~7.0	5.0±0.5	0.60±0.02	9.5	3.5±0.5	3.0~5.1

\*Coating material rating:UL 94 V-0

Electrical Characteristics ( Ambient  $T_a=25^{\circ}\text{C}$  )

Part No.	Varistor Voltage (@ 1mA DC)	Max. Continuous Voltage		Max. Clamping Voltage (8/20μS)		Max. Surge Current (8/20μS)	Max. Energy (10/1000μS)
	$V_{1mA}$ (V)	$V_{AC}(rms)$ (V)	$V_{DC}$ (V)	$V_p$ (V)	$I_p$ (A)	I (A)	W (J)
TVR05431KFC3FY-H	430 ± 10 %	275	350	745	5	400	13

Part No.	Rated Power	Impulse Response Time	Max. Leakage Current at 75% $V_{1mA}$	Operating Temperature Range	Storage temperature Range
	P (W)	nSec	$I_L(\mu A)$	( $^{\circ}\text{C}$ )	( $^{\circ}\text{C}$ )
TVR05431KFC3FY-H	0.1	<25	20	-40 ~ +105	-40 ~ +125

**Reliability**

Item	Standard	Test conditions / Methods	Specifications															
Tensile Strength of Terminals	IEC60068-2-21	Gradually applying the force specified and keeping the unit fixed for 10±1 sec.  <table style="margin-left: auto; margin-right: auto;"> <tr> <td style="text-align: center;">Terminal diameter (mm)</td> <td style="text-align: center;">Force (Kg)</td> </tr> <tr> <td style="text-align: center;">0.5&lt;d≤0.8</td> <td style="text-align: center;">1.0</td> </tr> <tr> <td style="text-align: center;">0.8&lt;d≤1.25</td> <td style="text-align: center;">2.0</td> </tr> <tr> <td style="text-align: center;">1.25&lt;d</td> <td style="text-align: center;">4.0</td> </tr> </table>	Terminal diameter (mm)	Force (Kg)	0.5<d≤0.8	1.0	0.8<d≤1.25	2.0	1.25<d	4.0	No visible damage   $\Delta V/V_{1mA}$   ≤5%							
Terminal diameter (mm)	Force (Kg)																	
0.5<d≤0.8	1.0																	
0.8<d≤1.25	2.0																	
1.25<d	4.0																	
Bending Strength of Terminals	IEC60068-2-21	Hold specimen and apply the force specified below to each lead. Bend the specimen to 90°, then return to the original position. Repeat the procedure in the opposite direction.  <table style="margin-left: auto; margin-right: auto;"> <tr> <td style="text-align: center;">Terminal diameter (mm)</td> <td style="text-align: center;">Force (Kg)</td> </tr> <tr> <td style="text-align: center;">0.5&lt;d≤0.8</td> <td style="text-align: center;">0.5</td> </tr> <tr> <td style="text-align: center;">0.8&lt;d≤1.25</td> <td style="text-align: center;">1.0</td> </tr> <tr> <td style="text-align: center;">1.25&lt;d</td> <td style="text-align: center;">2.0</td> </tr> </table>	Terminal diameter (mm)	Force (Kg)	0.5<d≤0.8	0.5	0.8<d≤1.25	1.0	1.25<d	2.0	No visible damage   $\Delta V/V_{1mA}$   ≤5%							
Terminal diameter (mm)	Force (Kg)																	
0.5<d≤0.8	0.5																	
0.8<d≤1.25	1.0																	
1.25<d	2.0																	
Vibration	IEC 60068-2-6	Frequency range:10~55Hz Amplitude:0.75mm or 98m/S <sup>2</sup> Direction:3 mutually perpendicular directions,2hrs each.	$\Delta V/V_{1mA}$   ≤5%    No visible damage															
Solderability	IEC60068-2-20	245 ± 3 °C , 3 ± 0.3 sec	At least 95% of terminal electrode is covered by new solder															
Resistance to Soldering Heat	IEC60068-2-20	260 ± 3 °C , 5 ± 1 sec	No visible damage   $\Delta V/V_{1mA}$   ≤5%															
High Temperature Storage	IEC60068-2-2	125 ± 5 °C , 1000 ± 24 hrs	No visible damage   $\Delta V/V_{1mA}$   ≤5%															
Damp Heat, Steady State	IEC 60068-2-78	The test is divided into two groups . a.40 ± 2°C , 90 ~ 95 % RH , 1344 hrs b.40 ± 2°C , 90 ~ 95 % RH , at 10%V <sub>DC</sub> , 1344 hrs	No visible damage   $\Delta V/V_{1mA}$   ≤10% Insulation Resistance ≥ 100MΩ															
Rapid Change of Temperature	IEC60068-2-14	The conditions shown below shall be repeated 5 cycles  <table border="1" style="margin-left: auto; margin-right: auto;"> <thead> <tr> <th>Step</th> <th>Temperature (°C)</th> <th>Period (minutes)</th> </tr> </thead> <tbody> <tr> <td style="text-align: center;">1</td> <td style="text-align: center;">-40 ± 3</td> <td style="text-align: center;">30 ± 3</td> </tr> <tr> <td style="text-align: center;">2</td> <td style="text-align: center;">Room temperature</td> <td style="text-align: center;">5 ± 3</td> </tr> <tr> <td style="text-align: center;">3</td> <td style="text-align: center;">105 ± 2</td> <td style="text-align: center;">30 ± 3</td> </tr> <tr> <td style="text-align: center;">4</td> <td style="text-align: center;">Room temperature</td> <td style="text-align: center;">5 ± 3</td> </tr> </tbody> </table>	Step	Temperature (°C)	Period (minutes)	1	-40 ± 3	30 ± 3	2	Room temperature	5 ± 3	3	105 ± 2	30 ± 3	4	Room temperature	5 ± 3	No visible damage   $\Delta V/V_{1mA}$   ≤5%
Step	Temperature (°C)	Period (minutes)																
1	-40 ± 3	30 ± 3																
2	Room temperature	5 ± 3																
3	105 ± 2	30 ± 3																
4	Room temperature	5 ± 3																
High Temp. Load	MIL-STD-202 Method 108	105 ± 2 °C , 1000 ± 24 hrs, at V <sub>DC</sub> or V <sub>rms</sub> (Max. Operating Voltage)	$\Delta V/V_{1mA}$   ≤10% No visible damage															



# Zinc Oxide Varistor TVR Type

Part No. :TVR05431KFC3FY-H

Item	Standard	Test conditions / Methods	Specifications
8/20 $\mu$ S Surge Life	IEC 61051-1 4.6	8/20us waveform, 10 surge currents, unipolar, interval 30secs, amplitude corresponding to max. Surge current derating curves for 20 $\mu$ s	$ \Delta V/V_{1mA}  \leq 10\%$ No visible damage
10/1000 $\mu$ S Surge Life	IEC 61051-1 4.6	10/1000 $\mu$ S waveform, 10 surge currents, unipolar, interval 2mins, amplitude corr. to max. surge current derating curves for 1000 $\mu$ S	$ \Delta V/V_{1mA}  \leq 10\%$ No visible damage
Varistor Voltage Temp. Coefficient	Specification Standard	$\frac{V_{1mA} \text{ at } 105^{\circ}\text{C} - V_{1mA} \text{ at } 25^{\circ}\text{C}}{V_{1mA} \text{ at } 25^{\circ}\text{C}} \times \frac{1}{80} \times 100 (\% / ^{\circ}\text{C})$ $\frac{V_{1mA} \text{ at } -40^{\circ}\text{C} - V_{1mA} \text{ at } 25^{\circ}\text{C}}{V_{1mA} \text{ at } 25^{\circ}\text{C}} \times \frac{1}{65} \times 100 (\% / ^{\circ}\text{C})$	$-0.05 \leq TC \leq 0.05 (\% / ^{\circ}\text{C})$
Voltage Proof	IEC 61051-1 4.9	Metal balls method, 2500 Vac 1 min	No visible damage

## Soldering Recommendation

### Wave Soldering Profile

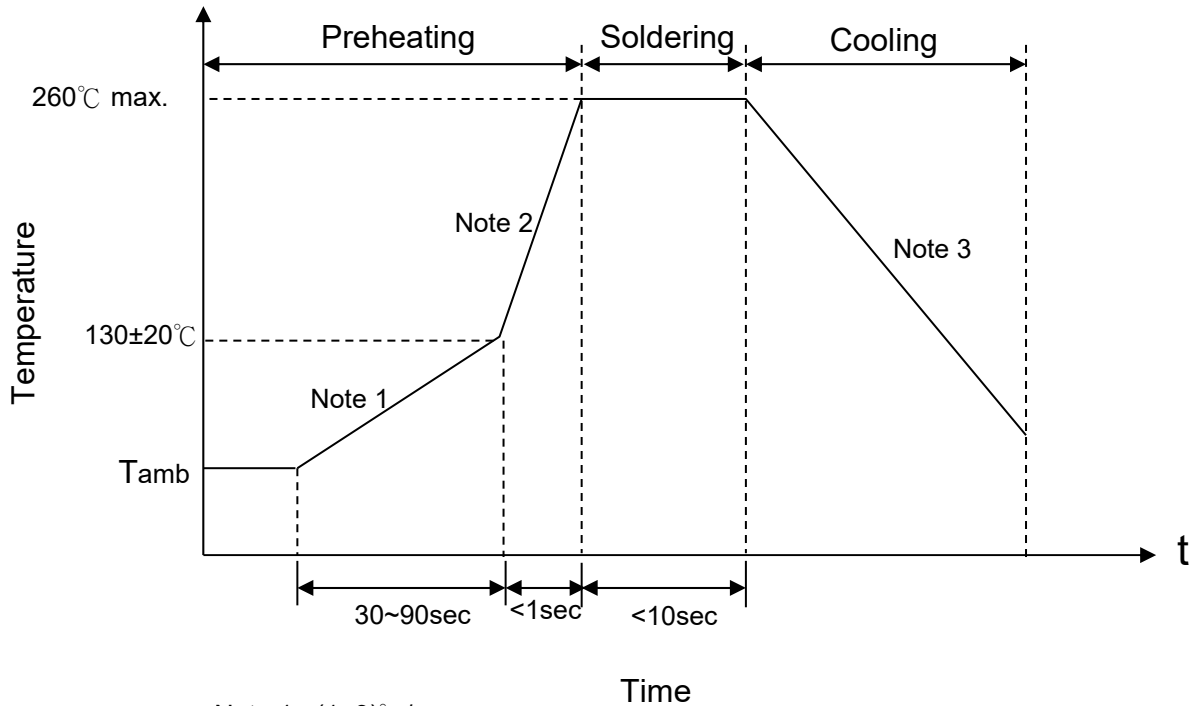

- Note 1 : (1~3)°C/sec  
 Note 2 : Approx. 200°C/sec  
 Note 3 : 5°C/sec Max

### Recommended Reworking Conditions with Soldering Iron

Item	Conditions
Temperature of Soldering Iron-tip	360°C (max.)
Soldering Time	3 sec (max.)
Distance from Varistor	2 mm (min.)



### Power Derating Curve

When operating temperature exceeds 105°C, the power, the Max.continuous operation Voltage, the Max.Surge Current and the Max.Energy should be derated as below figure, the derated coefficient is -5%.

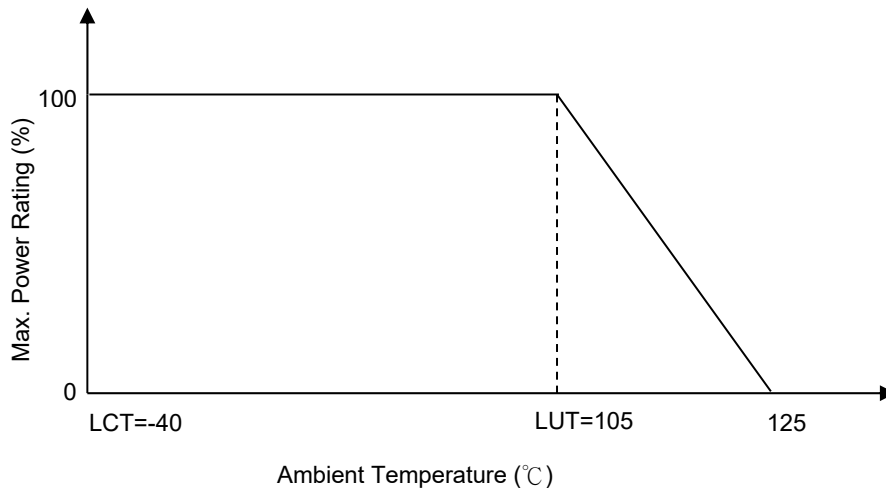

### RoHS Compliant Declaration

We hereby declare that the components delivered to your company are compliant with RoHS directive 2015/863/EU.

### Warehouse Storage Conditions of Products

(I) Storage Conditions :

- 1.Storage Temperature : -10°C~+40°C
- 2.Relative Humidity :  $\leq 75\%RH$
- 3.Keep away from corrosive atmosphere and sunlight.

(II) Period of Storage : 1 year

Safety Approvals (Certified Model/Type :TVR05431)

\* UL 1449 4th / cUL recognized (File # E314979)



\* TUV recognized (File J50411784)



\* CQC GB/T10193-1997 ` GB/T10194-1997 recognized  
(File # CQC03001005165/CQC03001007654)

Certificates

- (1) IATF 16949 certificate
- (2) ISO 9001 certificate

Test Report

- (1) RoHS test report



Max. Surge Current Derating Curves

TVR05431KFC3FY-H

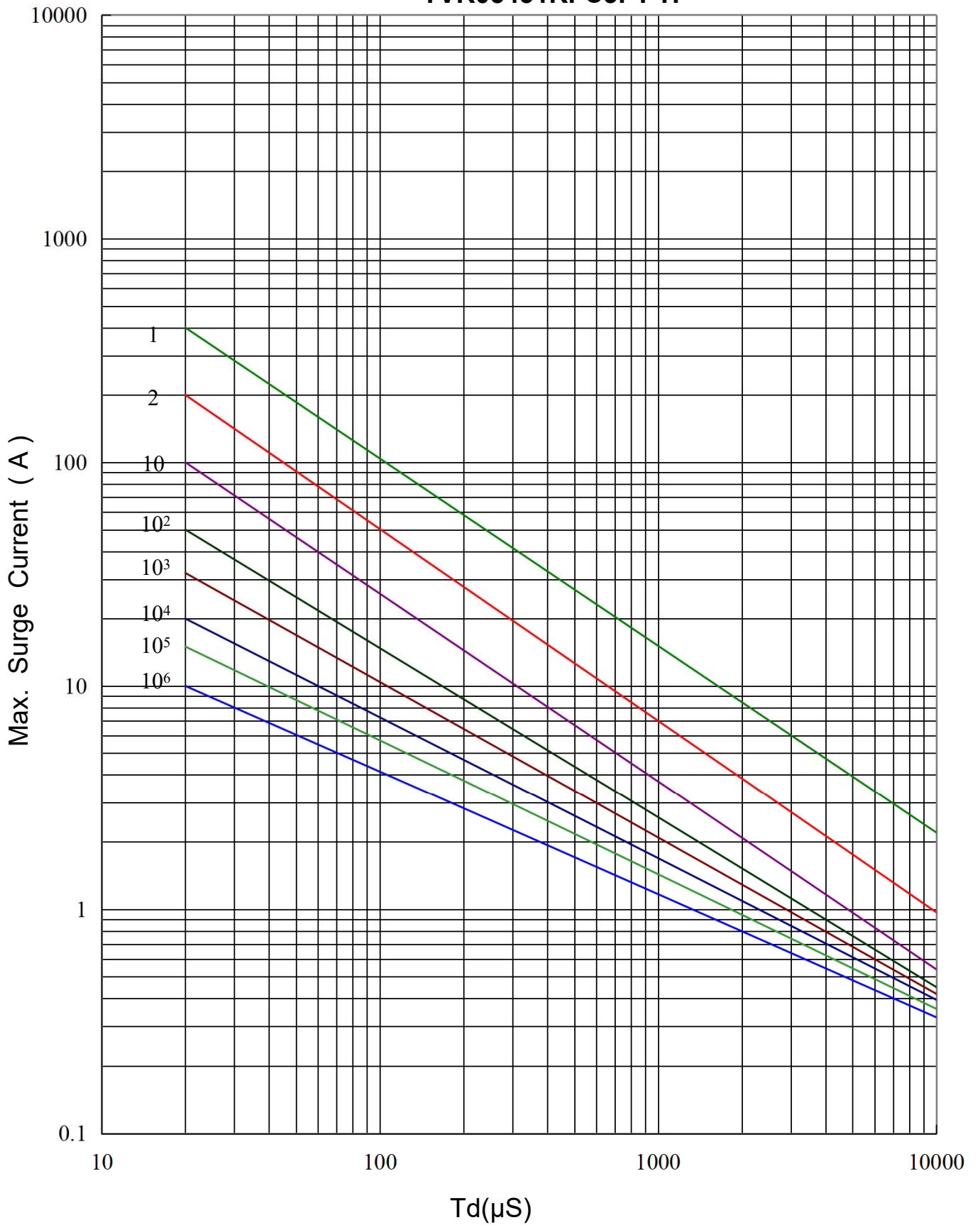



Max. Leakage Current and Max. Clamping Voltage Curve

TVR05431KFC3FY-H

