



THINKING ELECTRONIC INDUSTRIAL CO., LTD.

HEAD OFFICE: 12F, No.93, Dashun 1st Rd., Zuoying Dist., Kaohsiung, Taiwan
TEL: 886-7-5577660 FAX: 886-7-5570560

MANUFACTURING SITE

- KAOHSIUNG FACTORY 1: No. 51, Kaifa Rd., N.E.P.Z, Kaohsiung City 81170, Taiwan
TEL: 886-7-9616668 FAX: 886-7-9616698
- KAOHSIUNG FACTORY 2: No. 2-2, Xinjian S. Rd., N.E.P.Z., Kaohsiung City 81170, Taiwan
TEL: 886-7-9630001 FAX: 886-7-3635113
- CHANGZHOU FACTORY: No.6 Longmen Rd., Wujin High & New-Tech Industrial
Development Zone, Changzhou, Jiangsu, China 213161
TEL: 86-519-86578999 FAX: 86-519-86558643
- DONG GUAN FACTORY: No.45, East Rd., Sha-Tao Dist., Chang-An Town,
Dongguan City, Guangdong, China 523863
TEL: 86-769-85542016 FAX: 86-769-85546890
- YICHANG FACTORY: No. 283 Xiaoting Avenue, Xiaoting Dist., Yichang
City 443007, Hubei, China
TEL: 86-717-6510010 FAX: 86-717-6511430



SPECIFICATION FOR APPROVAL

CUSTOMER _____

CERTIFIED
MODEL/TYPE

TVA32112 -G

PART NO.

TVA32112KGKGE500(RoHS)

APPLICATION _____

CUSTOMER P/N _____

ISSUE DATE

Sep.01.2020

REV. NO. _____

REV. DATE _____

FOR CUSTOMER APPROVAL	CHECKED BY
	Yuan Yuan
	APPROVED BY
	Huaifang Zhang





REVISED RECORD SHEET

REV. NO	REV. DATE	REVISED CONTENT



INDEX	Page
■ Part Number Code	1
■ Structure and Dimensions	2
■ Electrical Characteristics	2
■ Reliability	3 ~ 4
■ Soldering Recommendation	5
■ Power Derating Curve	6
■ RoHS Compliant Declaration	6
■ Warehouse Storage Conditions of Products	6
■ Safety Approvals	7
■ Certificates	7
■ Max. Surge Current Derating Curves	8
■ Max. Leakage Current and Max. Clamping Voltage Curve	9

Part Number Code

Example :

TVA **32** **112** **K** **G** **KG** **E** **5** **00**
 (1) (2) (3) (4) (5) (6) (7) (8) (9)

No.	Item	Digit	Specification
(1)	Product Type	TVA	Thinking varistor TVA type
(2)	Size	32	φ 32 mm
(3)	Varistor Voltage	112	11 x 10 ² V = 1100V (V _{1mA})
(4)	Tolerance of V _{1mA}	K	±10%
(5)	Structure Type	G	Lead type
(6)	Terminal Type	KG	Straight type
(7)	Coating Material	E	Epoxy
(8)	RoHS Compliance	5	RoHS compliance
(9)	Optional Suffix	00	None special requirement

Structure and Dimensions

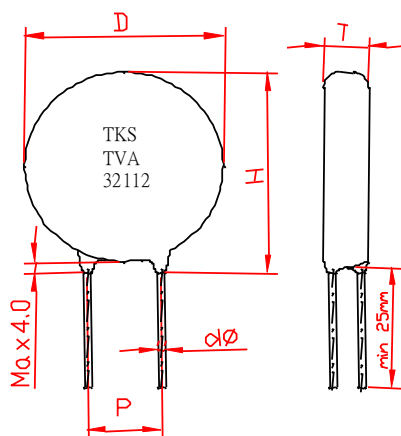

(unit : mm)

D	P	H	d	Tmax
32.5~36	15±1.0	33.5~41	1.5±0.02	8.8

Electrical Characteristics (Ambient Ta=25 °C)

Part No.	Varistor Voltage (@ 1mA DC)	Max. Continuous Voltage		Max. Clamping Voltage (8/20µS)		Max. Surge Current (8/20µS)	Max. Energy (2mS)
	V _{1mA} (V)	V _{AC(rms)} (V)	V _{DC} (V)	V _p (V)	I _p (A)	I (A)	W (J)
TVA32112KGKGE500	1100±10%	680	895	1815	200	25000	760

Part No.	Rated Power	Impulse Response Time	Max. Leakage Current at 75%V _{1mA}	Reference Capacitance @1KHZ	Operating Temperature Range	Storage temperature Range
	P (W)	nSec	I _L (µA)	C (pF)	(°C)	(°C)
TVA32112KGKGE500	1.2	<25	20	750	-40 ~ +85	-40 ~ +110



Reliability

Item	Standard	Test conditions / Methods	Specifications															
Tensile Strength of Terminals	IEC60068-2-21	<p>Gradually applying the force specified and keeping the unit fixed for 10±1 sec.</p> <table border="1"> <thead> <tr> <th>Terminal cross-sectional area(mm²)</th> <th>Terminal diameter (mm)</th> <th>Force (Kg)</th> </tr> </thead> <tbody> <tr> <td>0.5<S≤1.2</td> <td>0.8<d≤1.25</td> <td>2.0</td> </tr> <tr> <td>1.2<S</td> <td>1.25<d</td> <td>4.0</td> </tr> </tbody> </table>	Terminal cross-sectional area(mm ²)	Terminal diameter (mm)	Force (Kg)	0.5<S≤1.2	0.8<d≤1.25	2.0	1.2<S	1.25<d	4.0	<p>No visible damage ΔV/V_{1mA} ≤5%</p>						
Terminal cross-sectional area(mm ²)	Terminal diameter (mm)	Force (Kg)																
0.5<S≤1.2	0.8<d≤1.25	2.0																
1.2<S	1.25<d	4.0																
Vibration	IEC 1051-1	<p>Frequency range:10~55Hz Amplitude:0.75mm or 98m/S² Direction:3 mutually perpendicular directions,2hrs each.</p>	<p>No visible damage ΔV/V_{1mA} ≤5%</p>															
Solderability	IEC60068-2-20	245°C±3°C , 3±0.3S	At least 95% of terminal electrode is covered by new solder															
Resistance to Soldering Heat	IEC60068-2-20	260 ± 3 °C , 10 ± 1 sec	<p>No visible damage ΔV/V_{1mA} ≤5%</p>															
High Temperature Storage	IEC60068-2-2	110 ± 5 °C , 1000 ± 24 hrs	<p>No visible damage ΔV/V_{1mA} ≤5%</p>															
Damp Heat, Steady State	IEC 60068-2-78	<p>The test is divided into two groups . a.40 ± 2°C , 90 ~ 95 % RH , 1344 hrs b.40 ± 2°C , 90 ~ 95 % RH , at 10%V_{DC}, 1344 hrs</p>	<p>No visible damage ΔV/V_{1mA} ≤5% Insulation Resistance ≥ 100MΩ</p>															
Rapid Change of Temperature	IEC60068-2-14	<p>The conditions shown below shall be repeated 5 cycles</p> <table border="1"> <thead> <tr> <th>Step</th> <th>Temperature (°C)</th> <th>Period (minutes)</th> </tr> </thead> <tbody> <tr> <td>1</td> <td>-40 ± 3</td> <td>30 ± 3</td> </tr> <tr> <td>2</td> <td>Room temperature</td> <td>15 ± 3</td> </tr> <tr> <td>3</td> <td>85 ± 2</td> <td>30 ± 3</td> </tr> <tr> <td>4</td> <td>Room temperature</td> <td>15 ± 3</td> </tr> </tbody> </table>	Step	Temperature (°C)	Period (minutes)	1	-40 ± 3	30 ± 3	2	Room temperature	15 ± 3	3	85 ± 2	30 ± 3	4	Room temperature	15 ± 3	<p>No visible damage ΔV/V_{1mA} ≤5%</p>
Step	Temperature (°C)	Period (minutes)																
1	-40 ± 3	30 ± 3																
2	Room temperature	15 ± 3																
3	85 ± 2	30 ± 3																
4	Room temperature	15 ± 3																
Endurance at Upper Category Temperature	IEC61051-4.20	85 ± 2 °C , 1000 ± 24 hrs, at V _{DC} or V _{rms} (Max. Operating Voltage)	<p> ΔV/V_{1mA} ≤10% No visible damage</p>															
8/20μS Surge Life	CECC42000	10,000 pulses (8/20μS) ,unipolar, interval 10 secs ,amplitude corr. to max. Surge current derating curves for 20μS	<p> ΔV/V_{1mA} ≤ 10% No visible damage</p>															



Reliability

Item	Standard	Test conditions / Methods	Specifications
10/1000 μ S Surge Life	CECC42000	10/1000 μ S waveform, 10 surge currents, unipolar, interval 2mins, amplitude corr. to max. surge current derating curves for 1000 μ S	$ \Delta V/V_{1mA} \leq 10\%$ No visible damage
Varistor Voltage Temp. Coefficient	Specification Standard	$\frac{V_{1mA} \text{ at } 85^{\circ}\text{C} - V_{1mA} \text{ at } 25^{\circ}\text{C}}{V_{1mA} \text{ at } 25^{\circ}\text{C}} \times \frac{1}{60} \times 100 (\% / ^{\circ}\text{C})$ $\frac{V_{1mA} \text{ at } -40^{\circ}\text{C} - V_{1mA} \text{ at } 25^{\circ}\text{C}}{V_{1mA} \text{ at } 25^{\circ}\text{C}} \times \frac{1}{65} \times 100 (\% / ^{\circ}\text{C})$	$-0.05 \leq TC \leq 0.05 (\% / ^{\circ}\text{C})$
Voltage Proof	IEC61051-4.9	Metal balls method, 2500 Vac 1 min	No visible damage

Soldering Recommendation

■ Wave Soldering Profile

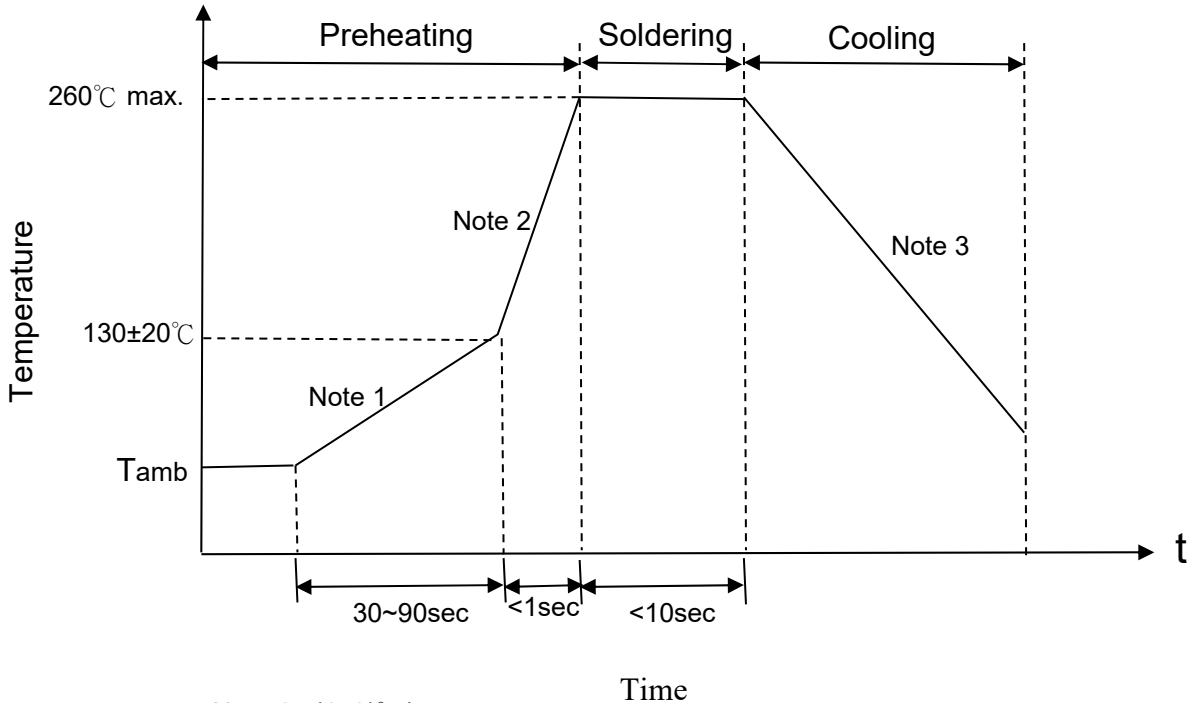

- Note 1 : $(1\sim 3)^\circ\text{C/sec}$
 Note 2 : Approx. 200°C/sec
 Note 3 : 5°C/sec Max

■ Recommended Reworking Conditions with Soldering Iron

Item	Conditions
Temperature of Soldering Iron-tip	360°C (max.)
Soldering Time	3 sec (max.)
Distance from Varistor	2 mm (min.)

Power Derating Curve

When operating temperature exceeds 85°C, the power, the Max.continuous operation Voltage,the Max.Surge Current and the Max.Energy should be derated as below figure, the derated coefficient is -4%.

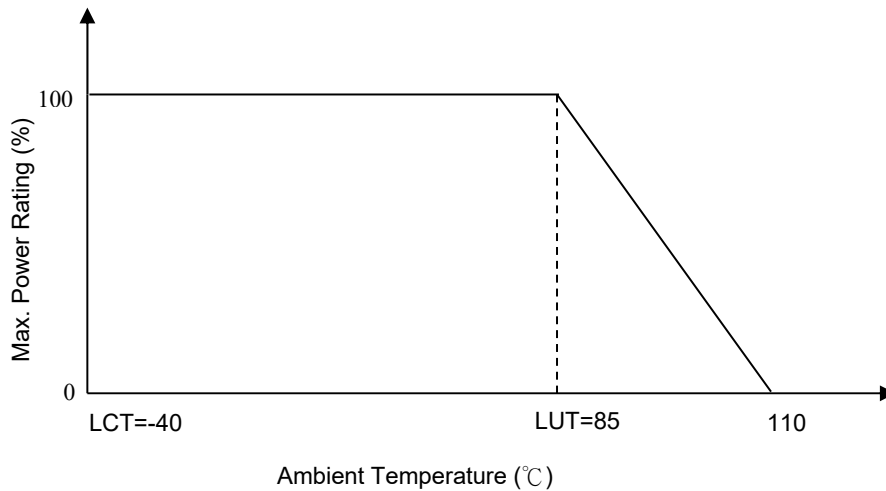

RoHS Compliant Declaration

We hereby declare that the components delivered to your company are compliant with RoHS directive 2011/65/EU.

Warehouse Storage Conditions of Products

(I) Storage Conditions :

- 1.Storage Temperature : -10°C~+40°C
- 2.Relative Humidity : $\leq 75\%RH$
- 3.Keep away from corrosive atmosphere and sunlight.

(II) Period of Storage : 1 year

Safety Approvals (Certified Model/Type :TVA32112-G)



* UL 1449 4th / cUL recognized (File # E314979)

Certificates

- (1) IATF 16949 certificate
- (2) ISO 9001 certificate

Test Report

- (1) RoHS test report



Max. Surge Current Derating Curves

TVA32112KGKGE500

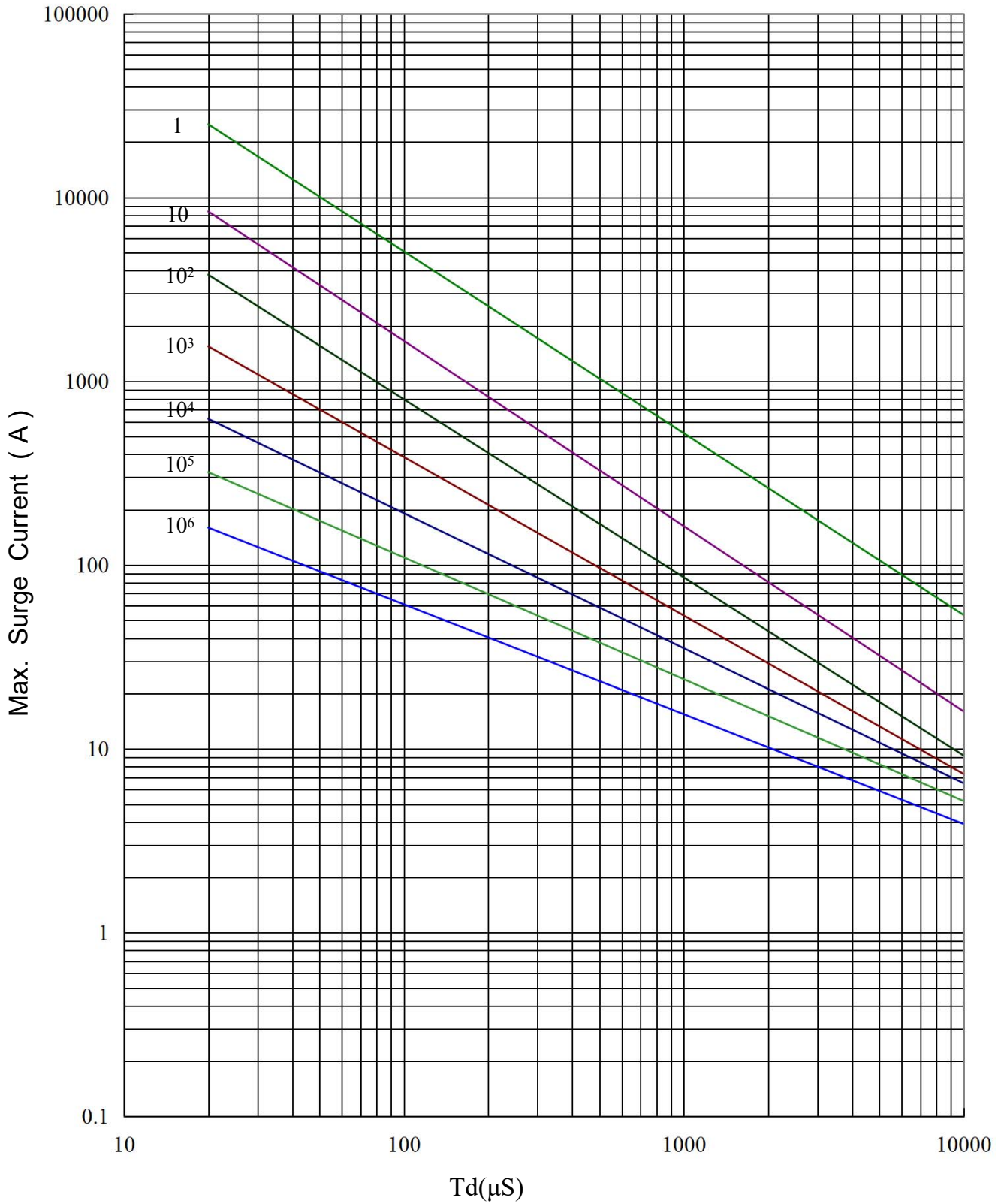

Max. Leakage Current and Max. Clamping Voltage Curves

