

## N-Channel Trench Power MOSFET

### General Description

The HL20N04 uses advanced trench technology to provide excellent  $R_{DS(ON)}$ , low gate charge and operation with gate voltages as low as 4.5V. This device is suitable for use as a wide variety of applications.

### Features

- $V_{DS} = 40V, I_D = 20A$   
 $R_{DS(ON)} < 20m\Omega @ V_{GS} = 10V$   
 $R_{DS(ON)} < 34m\Omega @ V_{GS} = 4.5V$
- High Power and current handling capability
- Lead free product is acquired
- Surface Mount Package

### Application

- PWM applications
- Load switch
- Power management

**100% UIS TESTED!**  
**100%  $\Delta V_{ds}$  TESTED!**

### SOT-89-3L

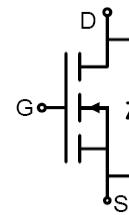
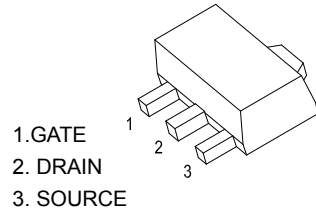

**Schematic Diagram**

### Package Marking and Ordering Information

Device Marking	Device	Device Package	Quantity
HL20N04	HL20N04	SOT-89	1000

**Table 1. Absolute Maximum Ratings ( $T_A=25^\circ C$ )**

Symbol	Parameter	Value	Unit
$V_{DS}$	Drain-Source Voltage ( $V_{GS}=0V$ )	40	V
$V_{GS}$	Gate-Source Voltage ( $V_{DS}=0V$ )	$\pm 20$	V
$I_D$	Drain Current-Continuous( $T_C=25^\circ C$ )	20	A
	Drain Current-Continuous( $T_C=100^\circ C$ )	21	A
$I_{DM (pluse)}$	Drain Current-Continuous@ Current-Pulsed <sup>(Note 1)</sup>	120	A
$P_D$	Maximum Power Dissipation( $T_C=25^\circ C$ )	38	W
	Maximum Power Dissipation( $T_C=100^\circ C$ )	19	W
$E_{AS}$	Avalanche energy <sup>(Note 2)</sup>	100	mJ
$T_J, T_{STG}$	Operating Junction and Storage Temperature Range	-55 To 175	$^\circ C$

**Table 2. Thermal Characteristic**

Symbol	Parameter	Value	Unit
$R_{\theta JC}$	Thermal Resistance, Junction-to-Case	4	$^\circ C/W$

**Table 3. Electrical Characteristics (TA=25°C unless otherwise noted)**

Symbol	Parameter	Conditions	Min	Typ	Max	Unit
<b>On/Off States</b>						
$BV_{DSS}$	Drain-Source Breakdown Voltage	$V_{GS}=0V, I_D=250\mu A$	40			V
$I_{DSS}$	Zero Gate Voltage Drain Current	$V_{DS}=40V, V_{GS}=0V$			1	$\mu A$
$I_{GSS}$	Gate-Body Leakage Current	$V_{GS}=\pm 20V, V_{DS}=0V$			$\pm 100$	nA
$V_{GS(th)}$	Gate Threshold Voltage	$V_{DS}=V_{GS}, I_D=250\mu A$	1	2	3	V
$g_{FS}$	Forward Transconductance	$V_{DS}=5V, I_D=10A$		18		S
$R_{DS(ON)}$	Drain-Source On-State Resistance	$V_{GS}=10V, I_D=20A$		14	20	m $\Omega$
		$V_{GS}=4.5V, I_D=15A$		24	34	m $\Omega$
<b>Dynamic Characteristics</b>						
$C_{iss}$	Input Capacitance	$V_{DS}=25V, V_{GS}=0V, f=1.0MHz$		840		pF
$C_{oss}$	Output Capacitance			92		pF
$C_{rss}$	Reverse Transfer Capacitance			60		pF
$R_g$	Gate resistance	$V_{GS}=0V, V_{DS}=0V, f=1.0MHz$		2.7		$\Omega$
<b>Switching Times</b>						
$t_{d(on)}$	Turn-on Delay Time	$V_{GS}=10V, V_{DS}=15V, R_L=0.75\Omega, R_{GEN}=3\Omega$		5		nS
$t_r$	Turn-on Rise Time			12		nS
$t_{d(off)}$	Turn-Off Delay Time			20		nS
$t_f$	Turn-Off Fall Time			4.5		nS
$Q_g$	Total Gate Charge	$V_{GS}=10V, V_{DS}=15V, I_D=20A$		20		nC
$Q_{gs}$	Gate-Source Charge			2.5		nC
$Q_{gd}$	Gate-Drain Charge			4.5		nC
<b>Source-Drain Diode Characteristics</b>						
$I_{SD}$	Source-Drain Current(Body Diode)				20	A
$V_{SD}$	Forward on Voltage	$V_{GS}=0V, I_S=20A$			1.2	V
$t_{rr}$	Body Diode Reverse Recovery Time	$I_F=20A, di/dt=100A/\mu s$		7		ns
$Q_{rr}$	Body Diode Reverse Recovery Charge	$I_F=20A, di/dt=100A/\mu s$		5		nC

Notes 1.Repetitive Rating: Pulse width limited by maximum junction temperature

 Notes 2.EAS condition:  $T_J=25^\circ C, V_{DD}=15V, V_G=10V, R_G=25\Omega$

## Test Circuit

### 1) $E_{AS}$ Test Circuits

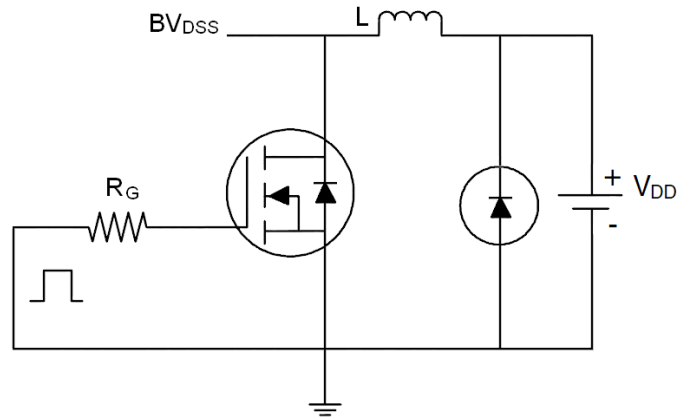
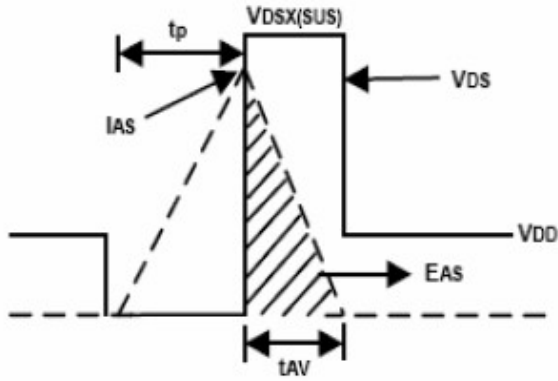

### 2) Gate Charge Test Circuit:

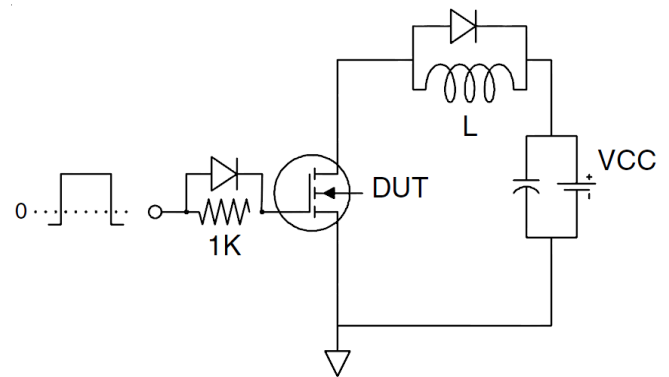
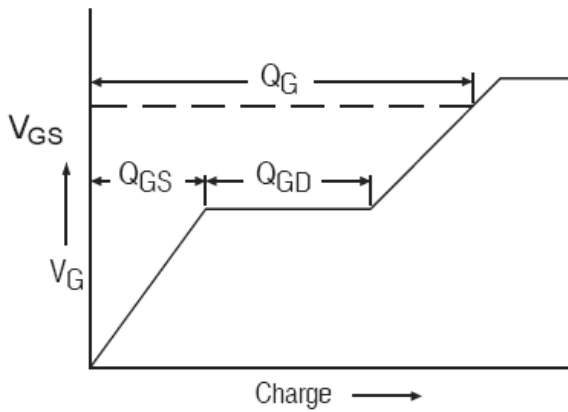

### 3) Switch Time Test Circuit:

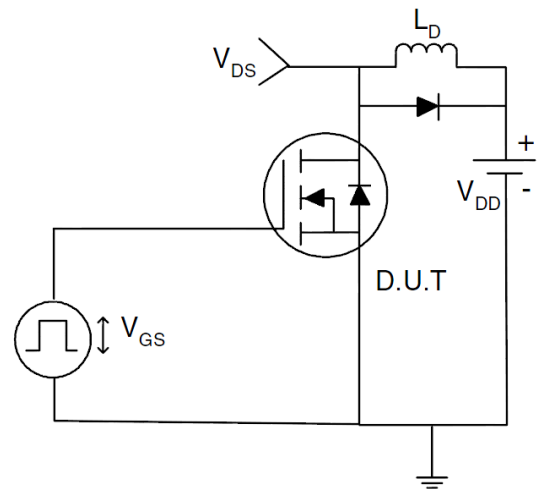
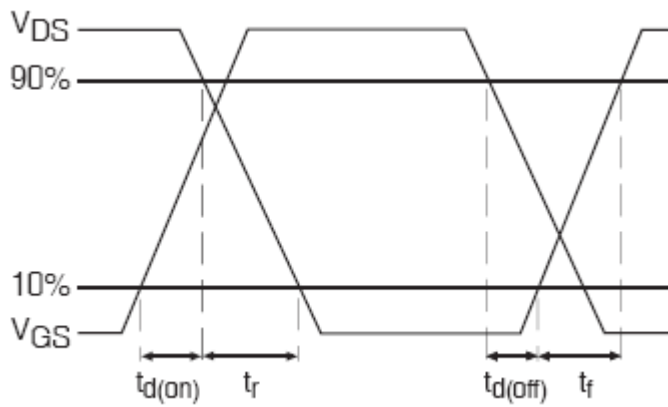

TYPICAL ELECTRICAL AND THERMAL CHARACTERISTICS (Curves)

Figure 1. Output Characteristics

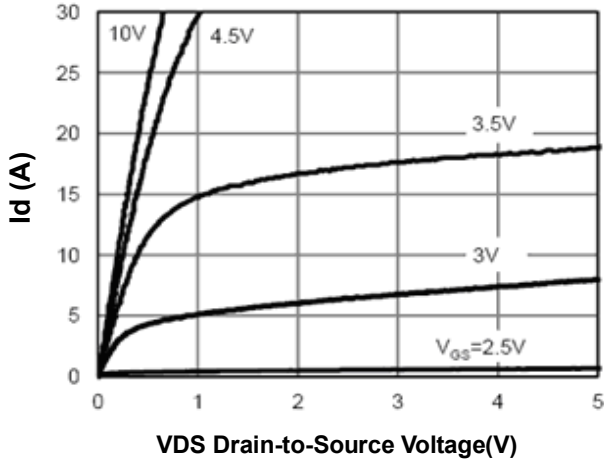

Figure 2. Transfer Characteristics

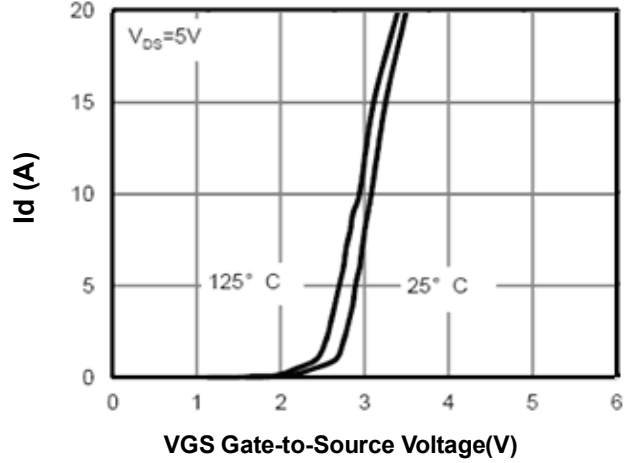

Figure 3. Max  $BV_{DSS}$  vs Junction Temperature

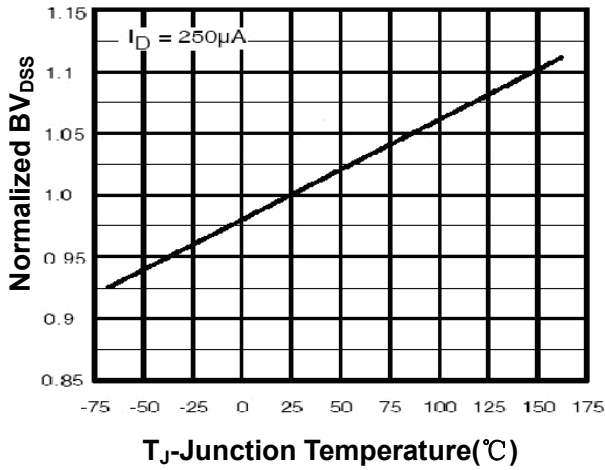

Figure 4. Drain Current

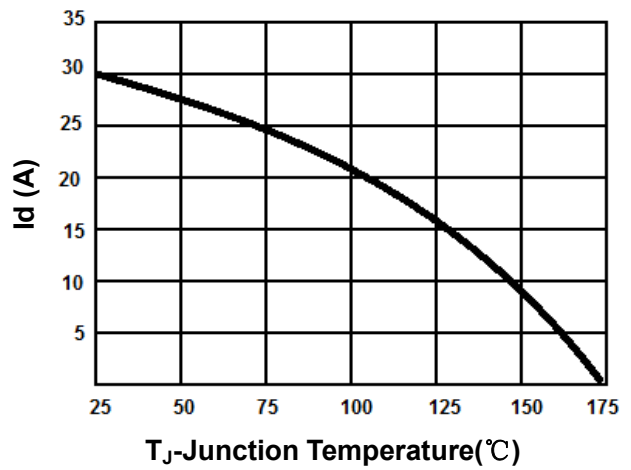

Figure 5.  $V_{GS(th)}$  vs Junction Temperature

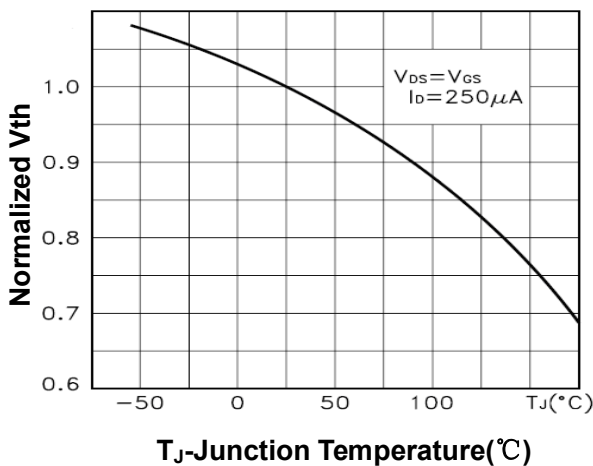

Figure 6.  $R_{DS(on)}$  vs Junction Temperature

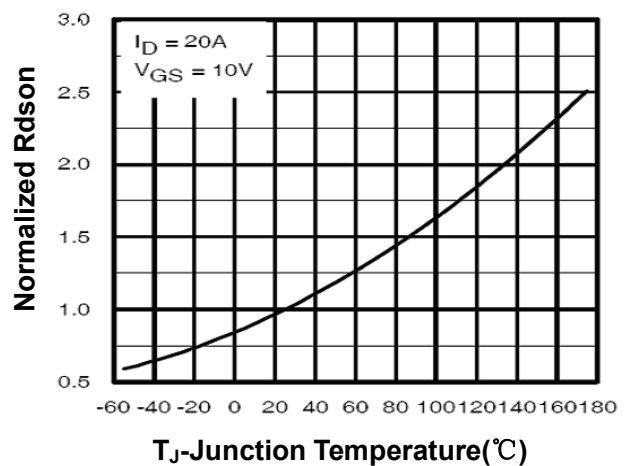

Figure 7. Gate Charge Waveforms

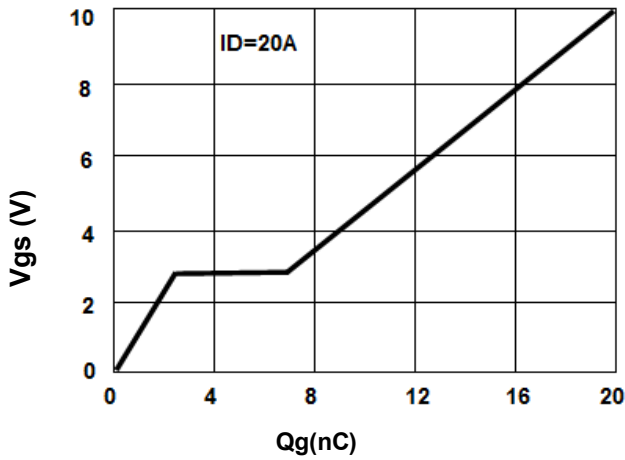

Figure 8. Capacitance

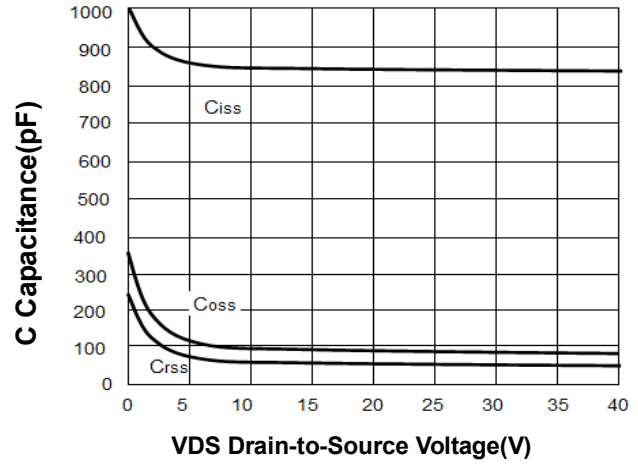

Figure 9. Body-Diode Characteristics

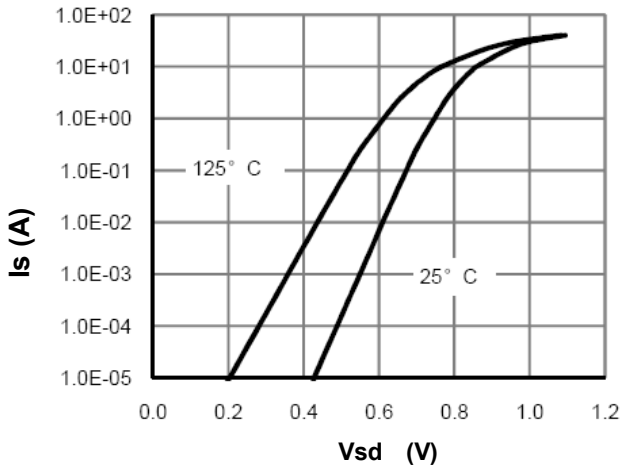

Figure 10. Maximum Safe Operating Area

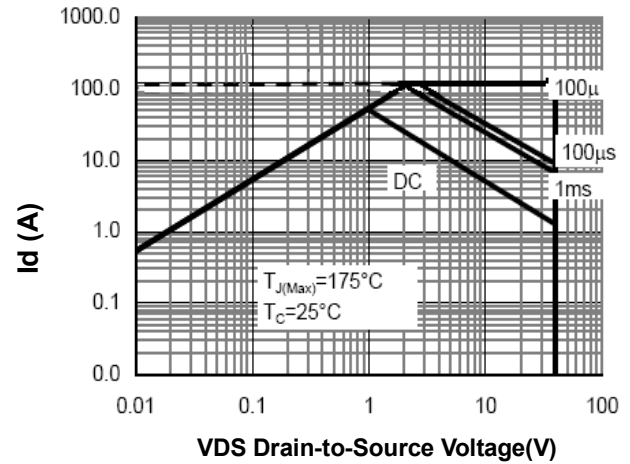
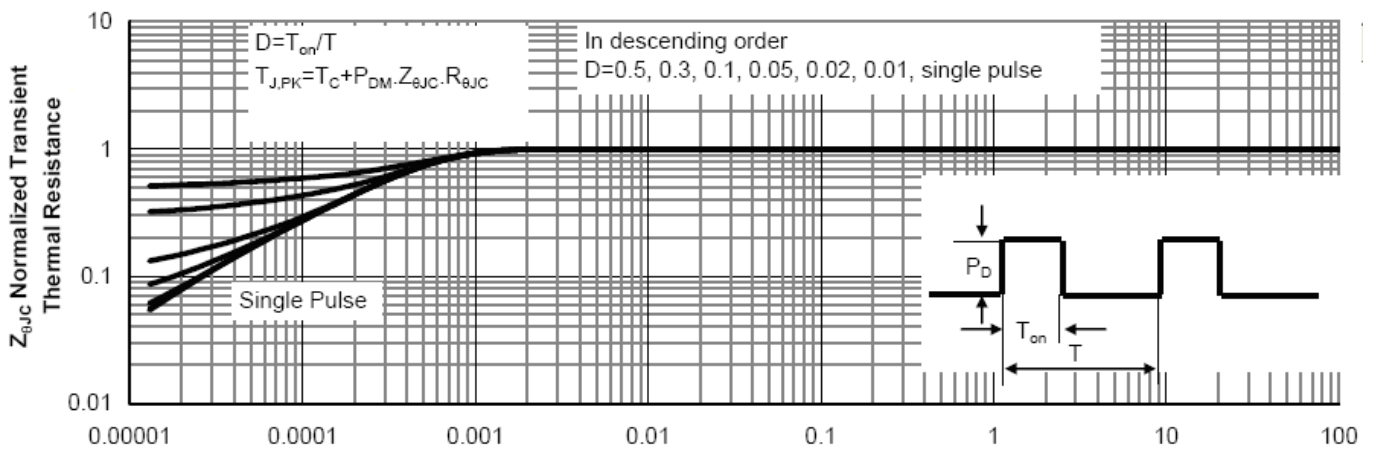
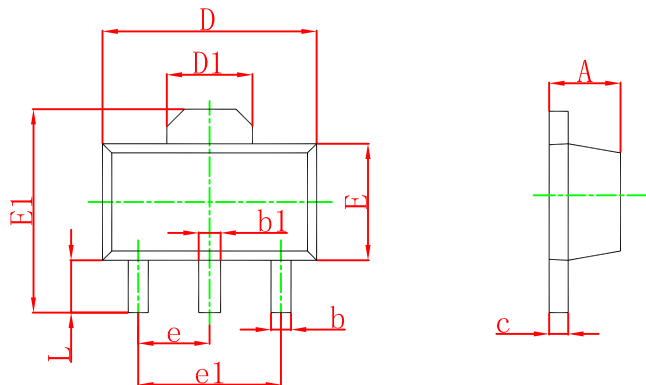

Figure 11. Normalized Maximum Transient Thermal Impedance



## TO-89 Package Information



Symbol	Dimensions In Millimeters		Dimensions In Inches	
	Min	Max	Min	Max
A	1.400	1.600	0.055	0.063
b	0.320	0.520	0.013	0.020
b1	0.400	0.580	0.016	0.023
c	0.350	0.440	0.014	0.017
D	4.400	4.600	0.173	0.181
D1	1.550 REF.		0.061 REF.	
E	2.300	2.600	0.091	0.102
E1	3.940	4.250	0.155	0.167
e	1.500 TYP.		0.060 TYP.	
e1	3.000 TYP.		0.118 TYP.	
L	0.900	1.200	0.035	0.047