

# THINKING ELECTRONIC INDUSTRIAL CO., LTD.

HEAD OFFICE: 8F-1, No.93, Ta-Shun 1st Rd., Kaohsiung, Taiwan  
 TEL: 886-7-5577660 FAX: 886-7-5570560

**MANUFACTURING SITE**

- KAOHSIUNG FACTORY: No.51, Kaifa Road, Nantze Export Processing Zone,  
Kaohsiung City 81170, Taiwan  
TEL: 886-7-9616668 FAX: 886-7-9616698
- CHANGZHOU FACTORY: No.82,Renmin Mid Rd.,WuJin High&New-Tech Industrial  
Development Zone,ChangZhou,JiangSu,China  
TEL:86-519-86578999 FAX:86-519-86558643
- DONG GUAN FACTORY: Chiao-Tou Tsun, Sha-Tao Hsiang, Chang-An Town,  
Dong-Guan City 523863, Guangdong, China  
TEL:86-769-85542016 FAX:86-769-85546890
- YICHANG FACTORY: No. 283 Xiaoting Avenue, Xiaoting Dist., Yichang  
City 443007, Hubei, China  
TEL:86-717-6510010 FAX:86-717-6511430



## SPECIFICATION FOR APPROVAL

**CUSTOMER**

<b>CERTIFIED MODEL/TYPE</b>	_____
	TVR10391
<b>PART NO.</b>	_____
	TVR10391KS34Y(RoHS)
<b>APPLICATION</b>	_____
<b>CUSTOMER P/N</b>	_____
<b>ISSUE DATE</b>	_____
	Jun.27,2014
<b>REV. NO</b>	_____
<b>REV. DATE</b>	_____

<b>FOR CUSTOMER APPROVAL</b>	<b>CHECKED BY</b>
	Yun Xu
	<b>APPROVED BY</b>
	Huaifang Zhang





**REVISED RECORD SHEET**

REV. NO	REV. DATE	REVISED CONTENT



<b>INDEX</b>	<b>Page</b>
■ Part Number Code	1
■ Structure and Dimensions	2
■ Electrical Characteristics	2
■ Reliability	3 ~ 4
■ Soldering Recommendation	5
■ Power Derating Curve	6
■ RoHS Compliant Declaration	6
■ Warehouse Storage Conditions of Products	6
■ Safety Approvals	7
■ Certificates	7
■ Max. Surge Current Derating Curves	8
■ Max. Leakage Current and Max. Clamping Voltage Curve	9

Part Number Code

Example :

**TVR**    **10**    **391**    **K**    **S**    **34Y**  
 (1)        (2)        (3)        (4)        (5)        (6)

No.	Item	Digit	Specification
(1)	Product Type	TVR	Thinking varistor TVR type
(2)	Body Size	10	φ 10 mm
(3)	Varistor Voltage	391	$39 \times 10^1 \text{ V} = 390\text{V} (V_{1\text{mA}})$
(4)	Tolerance of $V_{1\text{mA}}$	K	±10%
(5)	Appearance	S	Straight lead , epoxy coating
(6)	Optional Suffix	34Y	1.L min.:40mm 2.RoHS compliance

Structure and Dimensions

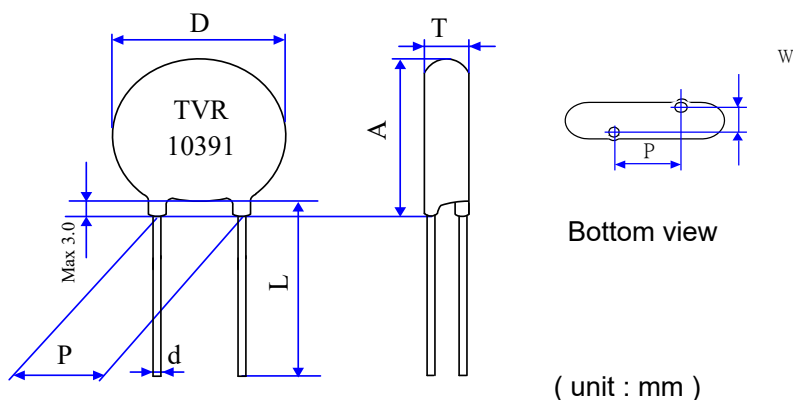

Body Size	D	P	d	A max.	L min.	T	W
φ 10	9.5~12.5	7.5±0.5	0.8±0.02	15.0	40	3.5~5.2	2.5±1.0

\*Coating material rating:UL 94 V-0

Electrical Characteristics ( Ambient Ta=25 °C )

Part No.	Varistor Voltage (@ 1mA DC)	Max. Continuous Voltage		Max. Clamping Voltage (8/20μS)		Max. Surge Current (8/20μS)	Max. Energy (10/1000μS)
	V <sub>1mA</sub> (V)	V <sub>AC(rms)</sub> (V)	V <sub>DC</sub> (V)	V <sub>p</sub> (V)	I <sub>p</sub> (A)	I (A)	W (J)
TVR10391KS34Y	390 ± 10 %	250	320	650	25	2500	60

Part No.	Rated Power	Impulse Response Time	Max. Leakage Current at 75%V <sub>1mA</sub>	Operating Temperature	Storage Temperature
	P (W)	nSec	I <sub>L</sub> (μA)	( °C )	( °C )
TVR10391KS34Y	0.4	<25	20	-40 ~ +85	-40 ~ +125

Reliability

Item	Standard	Test conditions / Methods	Specifications															
Tensile Strength of Terminals	IEC60068-2-21	Gradually applying the force specified and keeping the unit fixed for 10±1 sec.  <table style="margin-left: auto; margin-right: auto;"> <tr> <td style="text-align: center;">Terminal diameter (mm)</td> <td style="text-align: center;">Force (Kg)</td> </tr> <tr> <td style="text-align: center;">0.5&lt;d≤0.8</td> <td style="text-align: center;">1.0</td> </tr> <tr> <td style="text-align: center;">0.8&lt;d≤1.25</td> <td style="text-align: center;">2.0</td> </tr> <tr> <td style="text-align: center;">1.25&lt;d</td> <td style="text-align: center;">4.0</td> </tr> </table>	Terminal diameter (mm)	Force (Kg)	0.5<d≤0.8	1.0	0.8<d≤1.25	2.0	1.25<d	4.0	No visible damage $ \Delta V/V_{1mA}  \leq 5\%$							
Terminal diameter (mm)	Force (Kg)																	
0.5<d≤0.8	1.0																	
0.8<d≤1.25	2.0																	
1.25<d	4.0																	
Bending Strength of Terminals	IEC60068-2-21	Hold specimen and apply the force specified below to each lead. Bend the specimen to 90°, then return to the original position. Repeat the procedure in the opposite direction.  <table style="margin-left: auto; margin-right: auto;"> <tr> <td style="text-align: center;">Terminal diameter (mm)</td> <td style="text-align: center;">Force (Kg)</td> </tr> <tr> <td style="text-align: center;">0.5&lt;d≤0.8</td> <td style="text-align: center;">0.5</td> </tr> <tr> <td style="text-align: center;">0.8&lt;d≤1.25</td> <td style="text-align: center;">1.0</td> </tr> <tr> <td style="text-align: center;">1.25&lt;d</td> <td style="text-align: center;">2.0</td> </tr> </table>	Terminal diameter (mm)	Force (Kg)	0.5<d≤0.8	0.5	0.8<d≤1.25	1.0	1.25<d	2.0	No visible damage $ \Delta V/V_{1mA}  \leq 5\%$							
Terminal diameter (mm)	Force (Kg)																	
0.5<d≤0.8	0.5																	
0.8<d≤1.25	1.0																	
1.25<d	2.0																	
Vibration	IEC 60068-2-6	Frequency range:10~55Hz Amplitude:0.75mm or 98m/S <sup>2</sup> Direction:3 mutually perpendicular directions,2hrs each.	$ \Delta V/V_{1mA}  \leq 5\%$ No visible damage															
Solderability	IEC60068-2-20	245 ± 3 °C , 3 ± 0.3 sec	At least 95% of terminal electrode is covered by new solder															
Resistance to Soldering Heat	IEC60068-2-20	260 ± 3 °C , 10 ± 1 sec	No visible damage $ \Delta V/V_{1mA}  \leq 5\%$															
High Temperature Storage	IEC60068-2-2	125 ± 5 °C , 1000 ± 24 hrs	No visible damage $ \Delta V/V_{1mA}  \leq 5\%$															
Damp Heat, Steady State	IEC 60068-2-78	The test is divided into two groups . a.40 ± 2°C , 90 ~ 95 % RH , 1344 hrs b.40 ± 2°C , 90 ~ 95 % RH , at 10%V <sub>DC</sub> , 1344 hrs	No visible damage $ \Delta V/V_{1mA}  \leq 10\%$ Insulation Resistance ≥ 100MΩ															
Rapid Change of Temperature	IEC60068-2-14	The conditions shown below shall be repeated 5 cycles <table border="1" style="margin-left: auto; margin-right: auto;"> <thead> <tr> <th>Step</th> <th>Temperature (°C)</th> <th>Period (minutes)</th> </tr> </thead> <tbody> <tr> <td style="text-align: center;">1</td> <td style="text-align: center;">-40 ± 3</td> <td style="text-align: center;">30 ± 3</td> </tr> <tr> <td style="text-align: center;">2</td> <td style="text-align: center;">Room temperature</td> <td style="text-align: center;">5 ± 3</td> </tr> <tr> <td style="text-align: center;">3</td> <td style="text-align: center;">85 ± 2</td> <td style="text-align: center;">30 ± 3</td> </tr> <tr> <td style="text-align: center;">4</td> <td style="text-align: center;">Room temperature</td> <td style="text-align: center;">5 ± 3</td> </tr> </tbody> </table>	Step	Temperature (°C)	Period (minutes)	1	-40 ± 3	30 ± 3	2	Room temperature	5 ± 3	3	85 ± 2	30 ± 3	4	Room temperature	5 ± 3	No visible damage $ \Delta V/V_{1mA}  \leq 5\%$
Step	Temperature (°C)	Period (minutes)																
1	-40 ± 3	30 ± 3																
2	Room temperature	5 ± 3																
3	85 ± 2	30 ± 3																
4	Room temperature	5 ± 3																
High Temp. Load	MIL-STD-202 Method 108	85 ± 2 °C , 1000 ± 24 hrs, at V <sub>DC</sub> or V <sub>rms</sub> (Max. Operating Voltage)	$ \Delta V/V_{1mA}  \leq 10\%$ No visible damage															



Item	Standard	Test conditions / Methods	Specifications
8/20 $\mu$ S Surge Life	IEC 61051-1 4.6	10,000 pulses( 8/20 $\mu$ S ) , unipolar, interval 10 secs, amplitude corr. to max. Surge current derating curves for 20 $\mu$ S	$ \Delta V/V_{1mA}  \leq 10\%$ No visible damage
10/1000 $\mu$ S Surge Life	IEC 61051-1 4.6	10/1000 $\mu$ S waveform, 10 surge currents,unipolar,interval 2mins, amplitude corr. to max. surge current derating curves for 1000 $\mu$ S	$ \Delta V/V_{1mA}  \leq 10\%$ No visible damage
Varistor Voltage Temp. Coefficient	Specification Standard	$\frac{V_{1mA} \text{ at } 85^{\circ}\text{C} - V_{1mA} \text{ at } 25^{\circ}\text{C}}{V_{1mA} \text{ at } 25^{\circ}\text{C}} \times \frac{1}{60} \times 100 (\% / ^{\circ}\text{C} )$ $\frac{V_{1mA} \text{ at } -40^{\circ}\text{C} - V_{1mA} \text{ at } 25^{\circ}\text{C}}{V_{1mA} \text{ at } 25^{\circ}\text{C}} \times \frac{1}{65} \times 100 (\% / ^{\circ}\text{C} )$	$-0.05 \leq TC \leq 0.05 (\% / ^{\circ}\text{C} )$
Voltage Proof	IEC 61051-1 4.9	Metal balls method, 2500 Vac 1 min	No visible damage

## Soldering Recommendation

### Wave Soldering Profile

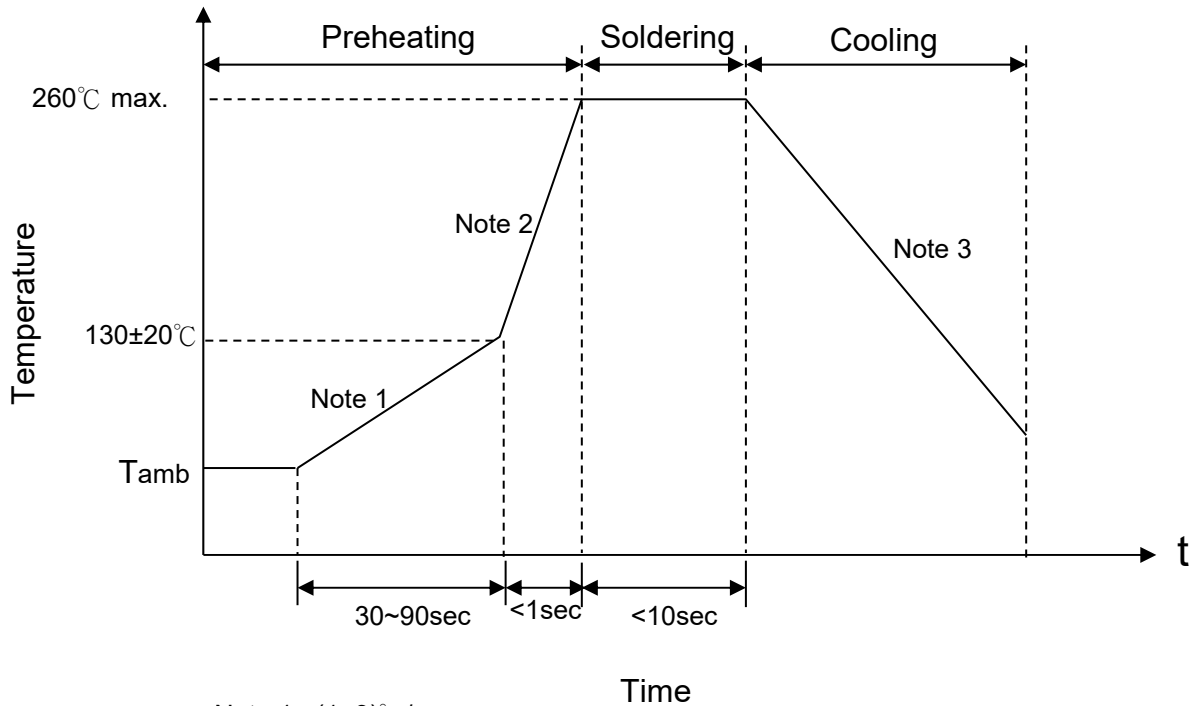

- Note 1 :  $(1\sim 3)^{\circ}\text{C/sec}$   
 Note 2 : Approx.  $200^{\circ}\text{C/sec}$   
 Note 3 :  $5^{\circ}\text{C/sec Max}$

### Recommended Reworking Conditions with Soldering Iron

Item	Conditions
Temperature of Soldering Iron-tip	$360^{\circ}\text{C (max.)}$
Soldering Time	3 sec (max.)
Distance from Varistor	2 mm (min.)



### Power Derating Curve

When operating temperature exceeds 85°C, the power, the Max.continuous operation Voltage, the Max.Surge Current and the Max.Energy should be derated as below figure, the derated coefficient is -2.5%.



### RoHS Compliant Declaration

We hereby declare that the components delivered to your company are compliant with RoHS directive 2011/65/EU.

### Warehouse Storage Conditions of Products

(I) Storage Conditions :

- 1.Storage Temperature : -10°C~+40°C
- 2.Relative Humidity :  $\leq 75\%RH$
- 3.Keep away from corrosive atmosphere and sunlight.

(II) Period of Storage : 1 year

Safety Approvals (Certified Model/Type:TVR10391)

\* UL 1449 3rd / cUL recognized (File # E314979)



\*CSA 22.2 recognized (File # 97495)



\* VDE IEC 61051-1:2007-04 / IEC 61051-2:1991  
IEC 61051-2-2:1991 recognized (File # 5944)



\* CQC GB/T10193-1997 ` GB/T10194-1997 recognized  
(File # CQC03001005165/CQC03001007654)

Certificates

- (1) TS 16949 certificate
- (2) ISO 9001 certificate

Test Report

- (1) RoHS test report



Max. Surge Current Derating Curves

TVR10391KS34Y

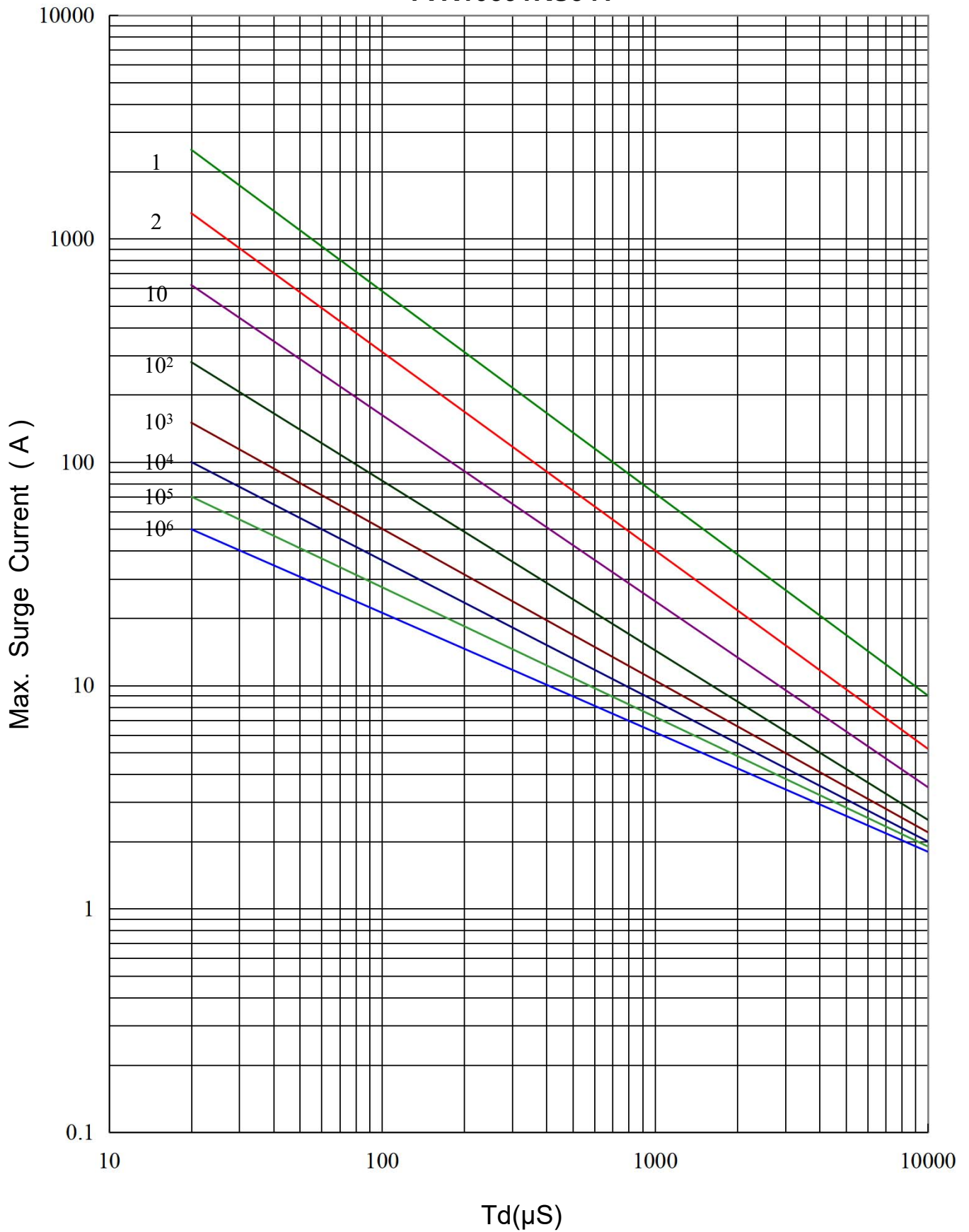



Max. Leakage Current and Max. Clamping Voltage Curve

