

MAPX	MODIFICATION	DATE

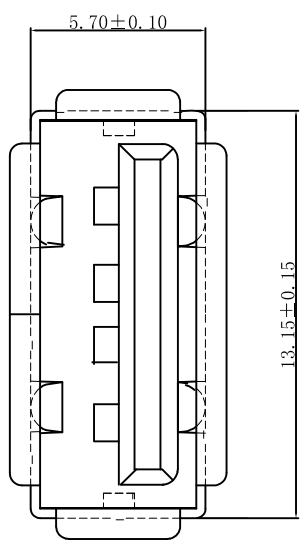
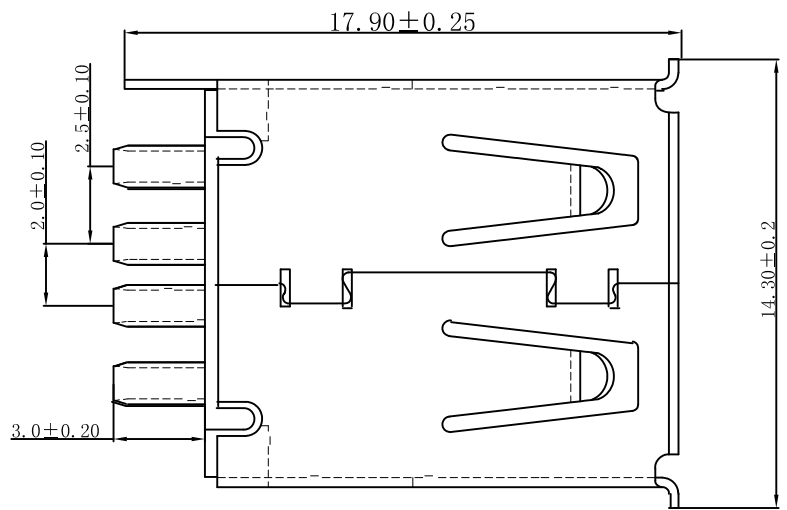
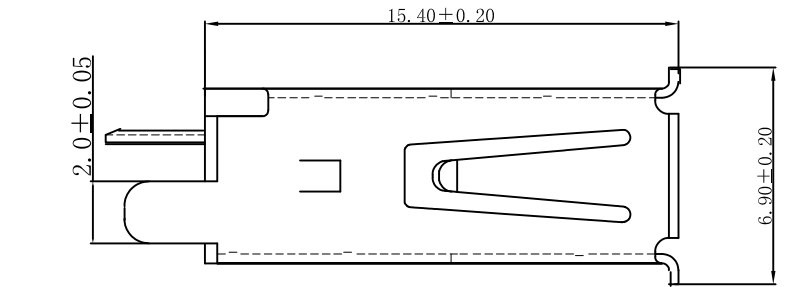

Note:

- Material:
 - Housing: PBT+G.F., UL94V-0
 - Contact: Stainless steel
 - Shell: Iron:Nickel plating for front cover, tinning for back cover
- Specification:
 - Current rating: 1 A Max.
 - Dielectric withstanding voltage: 500 V(ac) for 1 min.
 - Contact resistance: 30 mΩ Max.
 - Insulation resistance: 500 MΩ Min.
 - Total mating force: 3.57 Kgf Max.
 - 2500 insertion/extraction cycles
 - Temperature range: -30° C~80° C

产品图 PRODUCT CHART DWG				深圳市精拓金电子有限公司							
公差一览表 TOLERANCE UNLESS OTHERWISE				单位	MM	制图	尹先华	制图料号	916-751A1019W10201		
X.	±0.25	X.	±5°	比例	1:1	审核	郭治富	产品名称	AF180度15.3焊线式有边单脚铁壳白胶+护套		
.X	±0.20	.X	±2°	日期	2021-04-15	核准	黄国荣	角法			
.XX	±0.15	.XX	±1°	版本		APPD		VER	AO		
.XXX	±0.10	.XXX	±0.5°								

MAPX	MODIFICATION	DATE

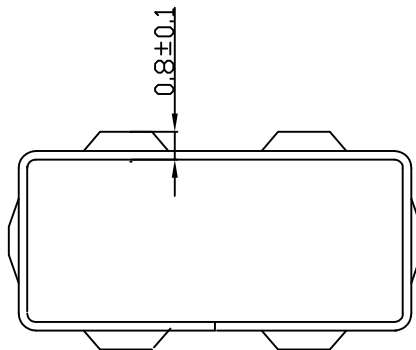
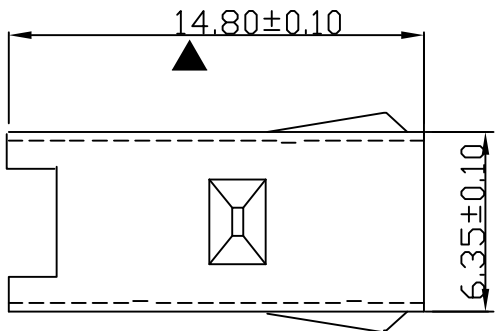

1. 材质: SPCC T= ≥0.30mm。
2. 电镀: 铜底 80U" 镍底 80U" 盐雾测试12H
3. 产品表面无明显毛边, 压痕, 划伤等现象。

标注"▲"的为重点管控尺寸

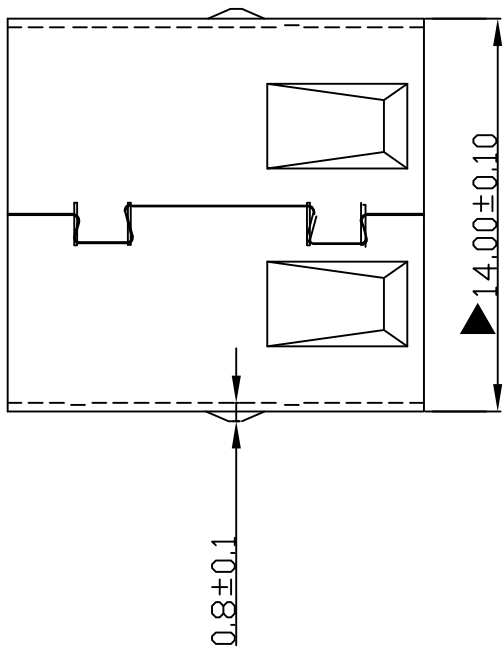

产品图 PRODUCT CHART DWG				深圳市精拓金电子有限公司							
公差一览表 TOLERANCE UNLESS OTHERWISE				单位	MM	制图	尹先华	制图料号	916-751A1019W10201		
X.	±0.15	X.	±5°	UNITS		DRAWING		PRODUCT PART NO.			
.X	±0.10	.X	±2°	比例	1:1	审核	郭治富	产品名称	AF180度15.3焊线式有边单脚铁壳白胶+护套		
.XX	±0.05	.XX	±1°	SCALE		核		PRODUCT NO.			
.XXX	±0.03	.XXX	±0.5°	日期	2021-04-15	核准	黄国荣	角法		版本	AO
				DATE		APPD		VIEW		VER	