

MAPX	MODIFICATION	DATE

NOTE:

- Material:
 - Housing: Thermoplastics
 - Contact: Phosphor Bronze C5191-EH/C2680-EH, T=0.25mm
 - Shell: COPPER ALLOY T=0.30mm
- FINISH:
 - Contact: 15u" Gold Plated on Contact Area, 80u" Min.Tin Plated on Solder Area, 50u" Min.Nickel Underplating Over All.
 - Shell: 50u" Min.Nickel Underplating Over All.
- Specification:
 - Rating:
 - Rated voltage 500V AC/DC. Rated current: 2 A Max.
 - Electrical:
 - Insulation Resistance(EIA-364-21): 1000M Ω Min. at 500V/DC for 1Minute.
 - Contact Resistance(EIA-364-23): 30 m Ω Max. at 20mV Max, 50mA
 - Dielectric Withstanding Voltage(EIA-364-20): No discharge, flashover or breakdown at 500V/AC 1Minute
- Plug extraction force shall be between 1.0kgf and 2.00kgf
- Contact finish:
 - 01: Selective Gold Flash
 - 02: Selective Gold 3U"
 - 03: Selective Gold 5U"
 - 04: Selective Gold 15U"
 - 05: Selective Gold 30U"

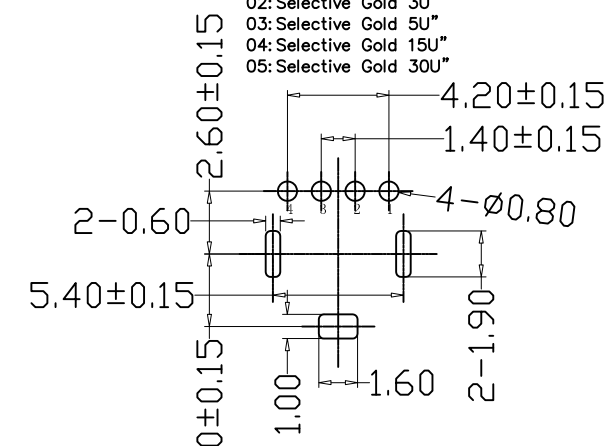
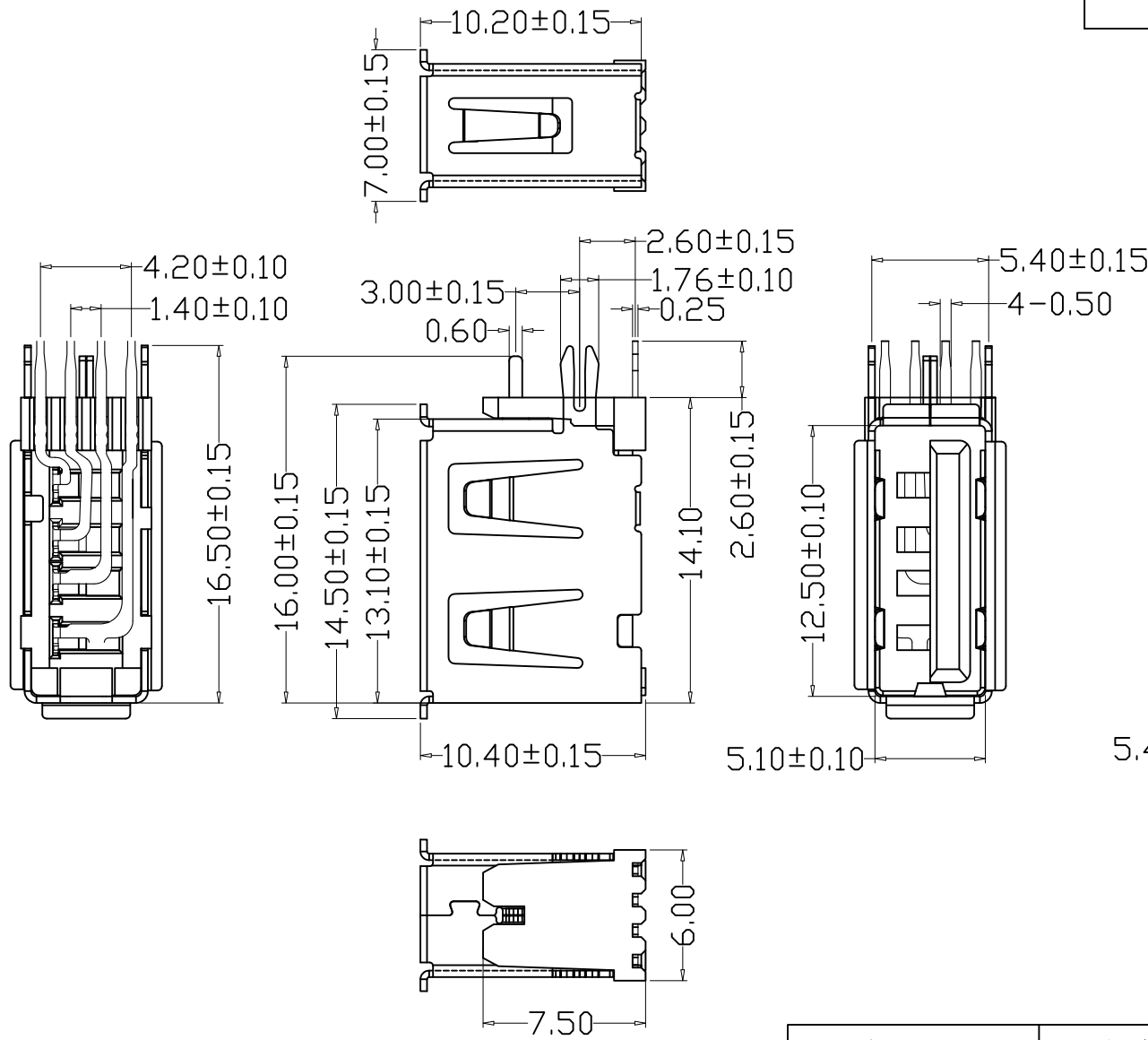

RECOMMENDED PCB LAYOUT
GENERAL TOLERANCES: ± 0.05

产品图 PRODUCT CHART DWG				深圳市精拓金电子有限公司						
公差一览表 TOLERANCE UNLESS OTHERWISE				单位	MM	制图	Z-Y-B	制图料号	906-752A1016D10200	
X.	± 0.25	X.	$\pm 5^\circ$	UNITS		DRAWING		PRODUCT PART NO.		
.X	± 0.20	.X	$\pm 2^\circ$	比例	1:1	审核		产品名称	AF10.0侧插短体外鱼叉内直脚有边	
.XX	± 0.15	.XX	$\pm 1^\circ$	SCALE		核准		PRODUCT NO.	铜壳加厚PBT白胶	
.XXX	± 0.10	.XXX	$\pm 0.5^\circ$	日期	2014.02.20	APPD		角法	\otimes \triangleleft	版本
				DATE				VIEW	VER	A0