

MAPX	MODIFICATION	DATE

NOTE:

- Material:
  - Housing: Thermoplastics, UL94V-0 (ROHS, HF)
  - Contact: Phosphor Bronze C5191-EH/C2680-EH, T=0.25mm
  - Shell: COPPER ALLOY T=0.30mm
- FINISH:
  - Contact: 15u" Gold Plated on Contact Area, 80u" Min. Tin Plated on Solder Area, 50u" Min. Nickel Underplating Over All.
  - Shell: 50u" Min. Nickel Underplating Over All.
- Specification:
  - Rating:
    - Rated voltage 500V AC/DC. Rated current: 2 A Max.
  - Electrical:
    - Insulation Resistance(EIA-364-21): 1000MΩ Min. at 500V/DC for 1Minute.
    - Contact Resistance(EIA-364-23): 30 mΩ Max. at 20mV Max, 50mA
    - Dielectric Withstanding Voltage(EIA-364-20): No discharge, flashover or breakdown at 500V/AC 1Minute
- Plug extraction force shall be between 1.0kgf and 2.00kgf
- Contact finish:
  - 01: Selective Gold Flash
  - 02: Selective Gold 3U"
  - 03: Selective Gold 5U"
  - 04: Selective Gold 15U"
  - 05: Selective Gold 30U"

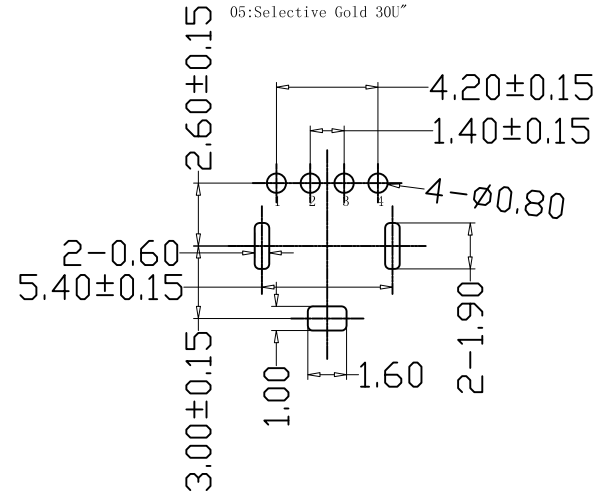
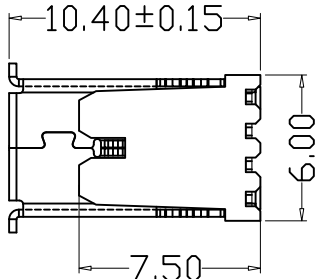
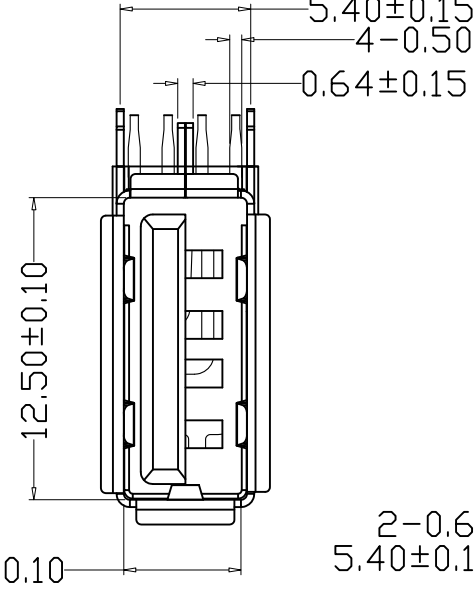
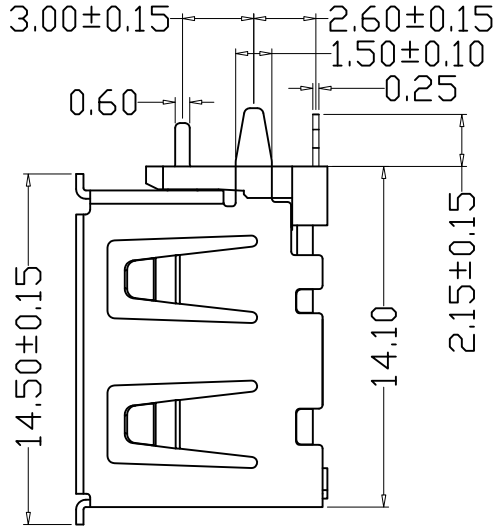
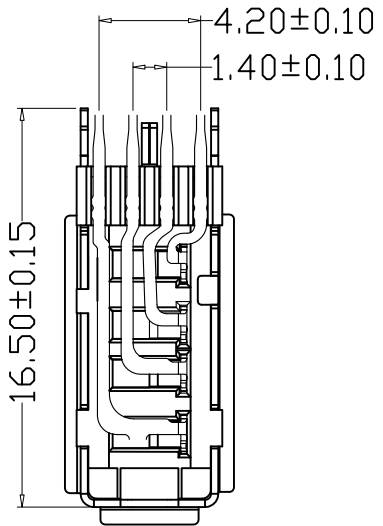
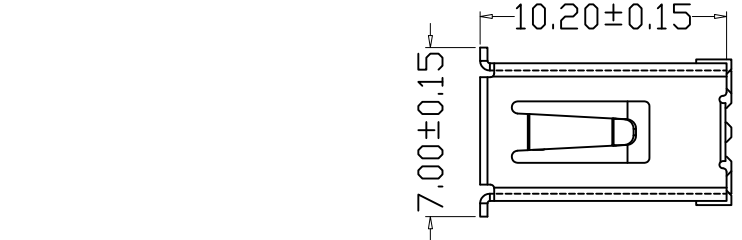

RECOMMENDED PCB LAYOUT  
GENERAL TOLERANCES: ±0.05

<p>产品图 PRODUCT CHART DWG</p> <p>公差一览表 TOLERANCE UNLESS OTHERWISE</p> <table border="1"> <tr> <td>X.</td> <td>±0.25</td> <td>X.</td> <td>±5.°</td> </tr> <tr> <td>.X</td> <td>±0.20</td> <td>.X</td> <td>±2.°</td> </tr> <tr> <td>.XX</td> <td>±0.15</td> <td>.XX</td> <td>±1.°</td> </tr> <tr> <td>.XXX</td> <td>±0.10</td> <td>.XXX</td> <td>±0.5°</td> </tr> </table>				X.	±0.25	X.	±5.°	.X	±0.20	.X	±2.°	.XX	±0.15	.XX	±1.°	.XXX	±0.10	.XXX	±0.5°	<p>深圳市精拓金电子有限公司</p>							
X.	±0.25	X.	±5.°																								
.X	±0.20	.X	±2.°																								
.XX	±0.15	.XX	±1.°																								
.XXX	±0.10	.XXX	±0.5°																								
单位 UNITS	MM	制图 DRAWING	Z-Y-B	制图料号 PRODUCT PART NO.	906-152B1116D10200																						
比例 SCALE	1:1	审核 CHKD		产品名称 PRODUCT NO.	AF10.0侧插短体三直脚有边铜壳反向加厚PBT橙胶																						
日期 DATE	2014.07.20	核准 APPD		角法 VIEW		版本 VER	A0																				