

REV	MODIFICATION	DATE
A0	胶芯变更	2013.12.20

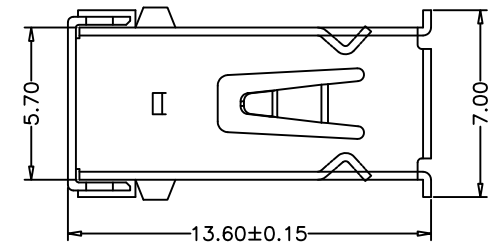

NOTE:

- Material:
  - Housing: Thermoplastics (ROHS, HF)
  - Contact: Phosphor Bronze C5191-EH/C2680-EH, T=0.25mm
  - Shell: COPPER ALLOY T=0.30mm
- FINISH:
  - Contact: 15u" Gold Plated on Contact Area, 80u" Min. Tin Plated on Solder Area, 50u" Min. Nickel Underplating Over All.
  - Shell: 50u" Min. Nickel Underplating Over All.
- Specification:
  - Rating:
    - Rated voltage 500V AC/DC. Rated current: 2 A Max.
  - Electrical:
    - Insulation Resistance (EIA-364-21): 1000MΩ Min. at 500V/DC for 1Minute.
    - Contact Resistance (EIA-364-23): 30 mΩ Max. at 20mV Max, 50mA
    - Dielectric Withstanding Voltage (EIA-364-20): No discharge, flashover or breakdown at 500V/AC 1Minute
- Plug extraction force shall be between 1.0kgf and 2.00kgf
- Contact finish:
  - 01: Selective Gold Flash
  - 02: Selective Gold 1U"
  - 03: Selective Gold 3U"
  - 04: Selective Gold 5U"
  - 05: Selective Gold 15U"
  - 06: Selective Gold 30U"

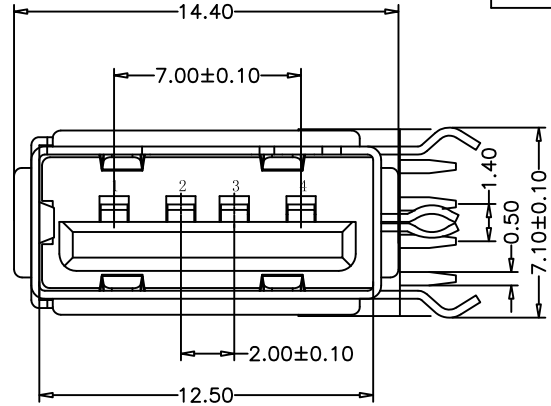
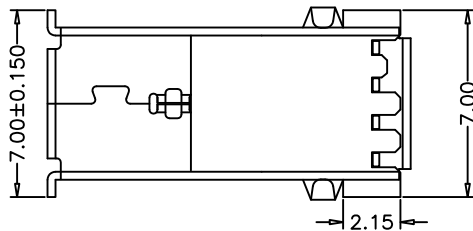
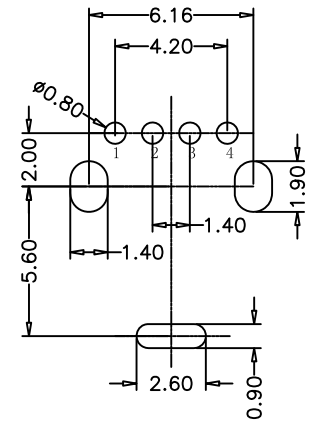
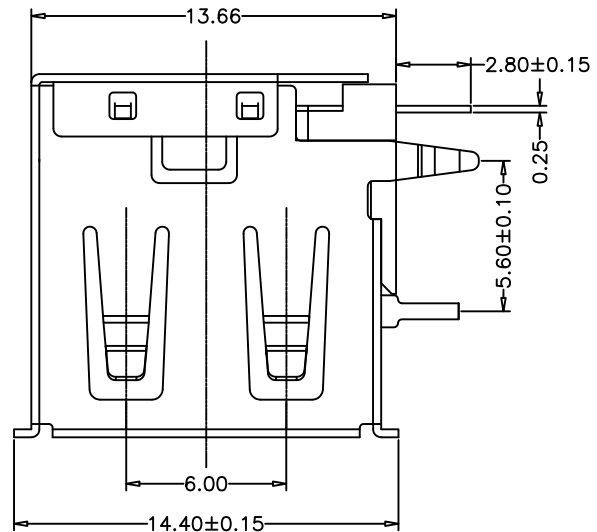

RECOMMENDED PCB LAYOUT  
GENERAL TOLERANCES: ±0.05

产品图 PRODUCT CHART DWG		深圳市精拓金电子有限公司							
公差一览表 TOLERANCE UNLESS OTHERWISE		单位 UNITS	MM	制图 DRAWING	Z-Y-B	制图料号 PRODUCT PART NO.	906-452A1012D10200		
X	±0.25	X	±5.°	比例 SCALE	1:1	审核 CHKD	产品名称 PRODUCT NO.		
.X	±0.20	.X	±2.°	日期 DATE	2013.12.20	核准 APPD	AF13.65侧插短体外弯内O型脚 有边铜壳PBT白胶		
.XX	±0.15	.XX	±1.°	角法 VIEW			版本 REV	A0	
.XXX	±0.10	.XXX	±0.5°						