

FSD-CON

承认书

PRODUCT SPECIFICATION

客户:		日期:	2020-7-24
CUSTOMER:		DATE:	2020-7-24

品名:	铝式固态电解电容
客户料号:	
富仕达料号:	EPPR1E471M6314TS
规格参数:	25V/470 μ F/ Φ 6.3x14L

批准 APPROVED BY			
姓名Name			
日期Code			

注: ROHS指令(2011/65/Eu)已经对应完毕

对承认书确认后, 在用户承认栏注明确认印, 返传一份于蔽公司, 谢谢

韶关富仕达电子科技有限公司

工厂地址: 韶关市乳源瑶族自治县城迎宾路一号

No.1 Yingbin Road, Ruyuan Yao Autonomous County, Shaoguan City, Guangdong Province, China

TEL:0751-6830668 FAX:0751-6830668

网址: <http://www.fsd-con.cn>

制作 PREPARED BY	审核 CHECKED BY	批准 APPROVED BY
张鲜花	黄东娣	徐巍

文件内容修改历史记录
RECORD OF REVISION

生效版本 REV.NO.	变更原因 REASON	修改内容 CONTENTS	承认时间 DATE OF	拟制 CHECKED	备注 REMARKS
1	客户要求	新项目送样	2020-7-24	徐巍	
2					
3					
4					
5					
6					
7					
8					
9					
10					
11					
12					
13					
14					
15					

产品系列编码表

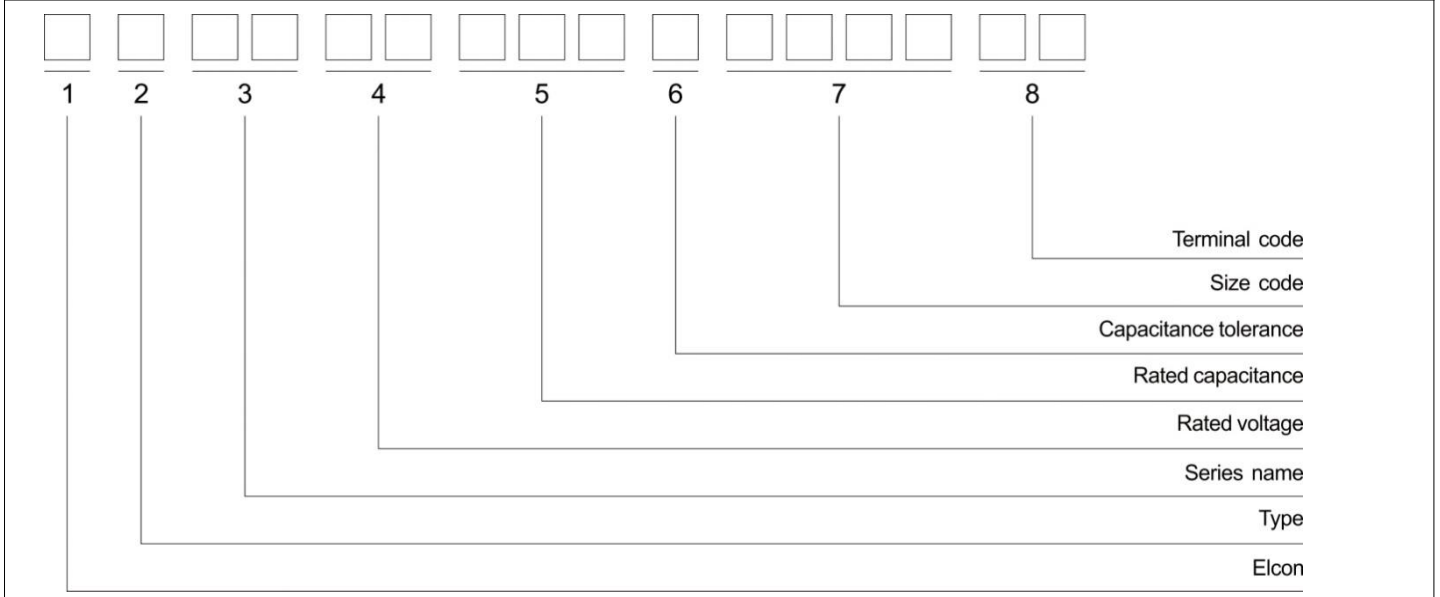

1	FSD-CON				
2	Type	Conductive Polymer Aluminum Solid Electrolytic Capacitors	Aluminum Electrolytic Capacitors	Aluminum Electrolytic Capacitors(Snap-in)	Aluminum Electrolytic Capacitors(Screw)
	Code	P U		S	G

3		4		5		6		7		8	
Series		Voltage (W.V.)	Code	Capacitance (μf)	Code	Cap. Tol. (%)	Code	Size Code Φ x L(mm)	Code	Terminal	Code
MA	TP	2.5	0E	0.1	0R1	±10	K	4x5.5	0455	Tape&Reel	TR
MB	HG	4	0G	0.22	R22	±20	M	4x7	0407	Bulk	BS
MS	EG	6.3	0J	0.33	R33	-10to+30	Q	5x7	0507	Taping	T
MV	GC	7.5	0T	0.47	R47	-10to+50	T	5x11	0511	Taping(Forming)	TF
MR	LR	10	1A	1	010	Special	A	5.5x11	5511	Taping(Straight)	TS
MX	LH	16	1C	2.2	2R2			6.3x5.5	6355	cutting (Dimension)	RC
PA	ZL	25	1E	3.3	3R3			6.3x6	6306	Forming Cut	RF
PB	LF	35	1V	4.7	4R7			6.3x7	6307	Forming Only	RM
PC	YA	40	1G	6.8	6R8			8x12	0812	Cutting&Bending (Left)	RL
PS	EB	50	1H	10	100			10x8	1008	Cutting&Bending (Right)	RR
PV	XF	63	1J	22	220			10x10	1010	Kinked Forming Cut	RK
PR	EH	75	1T	33	330			10x10.5	1010	Kinked Straight Cut	RY
PX	XH	80	1K	47	470			10x12.7	1012		
CK	GS	100	1R	68	680			10x20	1020		
EL	GH	125	2B	100	101			13x16	1316		
KL	MP	160	2C	330	331			13x20	1320		
KH	MZ	180	2Z	680	681			16x25	1625		
CH	KM	200	2D	1000	102			16x36	1636		
HU	MQ	220	2N	1200	122			22x20	2220		
LZ	MH	250	2E	1800	182			25x20	2520		
KZ	HPB	315	2F	2200	222			30x20	3020		
FZ	HPR	330	2U	2700	272			35x20	3520		
KP	HMB	350	2V	3300	332			35x45	3545		
SC	HMR	360	2X	4700	472			35x100	35A0		
SG		400	2G	5600	562			35x110	35B0		
SL		420	2M	6800	682			76x130	76D0		
LA		450	2W	10000	103			76x140	76E0		
SK		500	2H	15000	153						
UH				22000	223						

MA系列, Rated voltage(V)=6.3V, Rated Cpacitance(μF)=120(μF); Cpacitance Tolerrance=±20%; Case Size Φ x L(mm)=6.3x6;
P.N. : EPMA0J121M6306TR

一、概述 SCOPE

本产品规格书适用于富仕达电子科技有限公司固态铝电解电容产品。

The product specification is adapted to Polymer Aluminum Electrolytic Capacitors of FSD-CON ELECTRONICS TECHNOLOGY CO., LTD

二、外形图及尺寸表 Case size table

ΦD	6.3
L	14
P	2.5
Φd	0.6

三、技术性能 Specifications

1	系列号(SERIES)	PR					
2	额定电压 (rated voltage)	25					
3	工作温度范围 Operating temperature range	工作温度范围是指电容器在额定电压下能持续工作所允许外部环境的温度范围 operating temperature range is the range of ambient temperature at which the capacitor can be operated continuously at rated voltage SPEC:-55~+125℃					
4	电容容量 capacitance	测量等效电路图					
		测量温度20℃	measuring temperature				
		测量频率120HZ	measuring frequency				
		测量电压 0.5Vrms	measuring voltage				
		标称电容容量允许偏差:±20% MAX	Nominal Capacitance Tolerance:±20% MAX				
5	损耗角正切值的测量应要和测量电容容量一样的条件下进行 Measurement should be made under the same conditions as those given for the measurement of capacitance						
	SPEC:						
		损耗正切值 (tan δ)	<table border="1" style="margin-left: 20px;"> <tr> <td>$U_R(V)$</td> <td>25</td> </tr> <tr> <td>tanδ</td> <td>0.12</td> </tr> </table>	$U_R(V)$	25	tanδ	0.12
$U_R(V)$	25						
tanδ	0.12						
6	漏电流 leakage current	将额定电压加在电容和1000± 100Ω的保护电阻上。在充电2分钟后，按下列等式计算漏电流。 the rated voltage shall be applied across the capacitor and its protective resistor which shall be 1000±100Ω.The leakage current shall be then measured after an electrifications period of (A)min. The leakage current shall be calculated by the following equation. 在加上额定电压一定时间后，应满足下列要求：1 ≤0.2CV or 200μA Which is greater (取较大者) (20℃、2分钟) SPEC: The following specifications shall be satisfied when the rated voltage is applied for the required time.					
7	等效串联阻抗 Equivalent Series Resistance (ESR)	测量等效电路图 measuring circuit equivalent series circuit					
		测量温度20℃	measuring temperature				
		测量频率100KHZ	measuring frequency				
		测量电压0.5Vrms	measuring voltage				
8	允许最大纹波电流 Maximum permissible ripple current	在规定的某一频率下的最大交流电流，在该电流下电容器连续工作。即使在测过耐久性后，此要求仍要满足。在此，DC电压加上最大纹波电压小于等于额定电压。 The maximum sinusoidal alternating current of a frequency specified below, at which the capacitor can be operated continuously. This requirement shall be satisfied even after the measurement electrical endurance Where(DC voltage +peak ripple voltage)≤rated voltage					

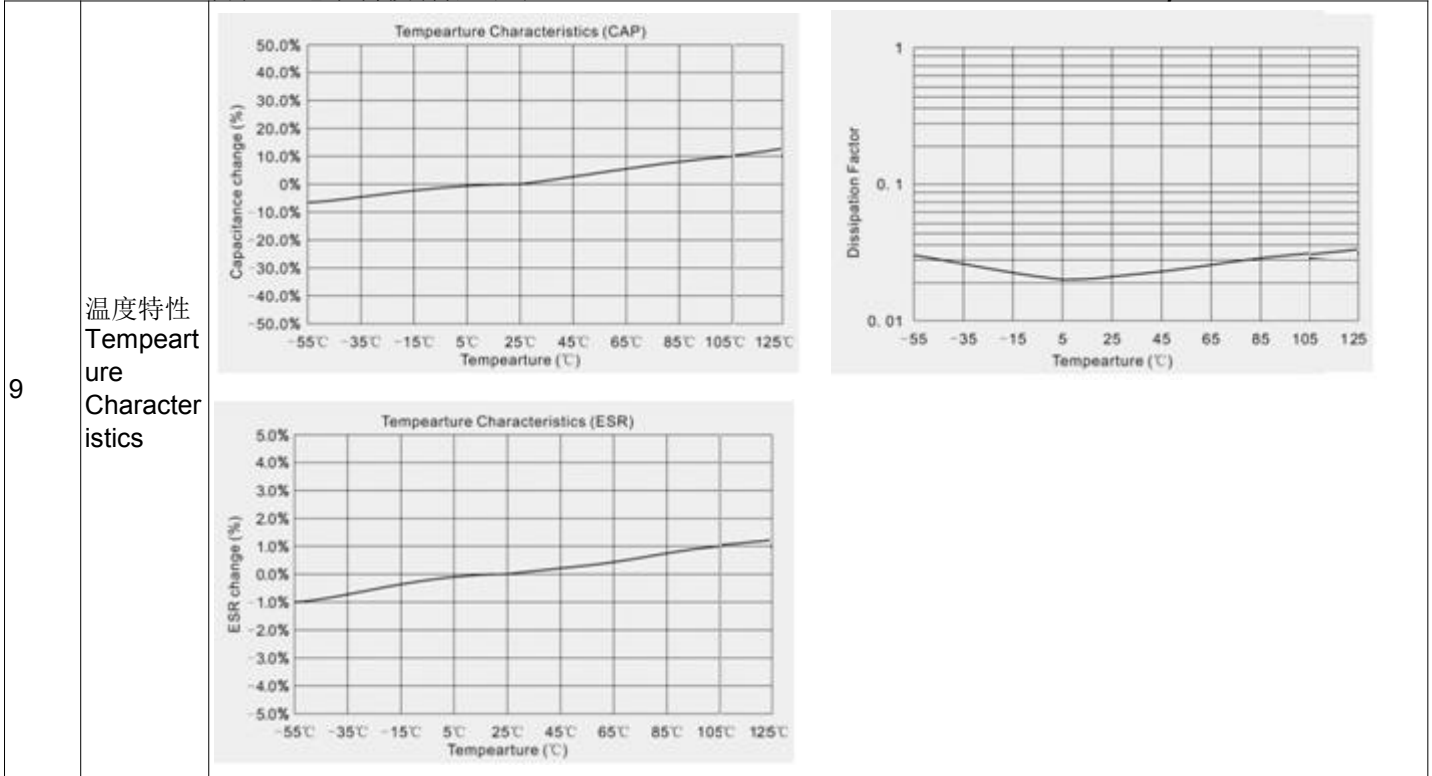

四、测试方法及要求 Tests

1	浪涌测试	<p>在规定温度下循环测试1000次，每次充电30±5秒，在放电大约5分30秒。在标准温度条件下存放使其稳定，然后再测试。 The capacitor shall be subjected to 1000 cycles at a temperature specified below, each consisting of a charge period of 30±5sec, followed by a discharge period of approx. 5min30sec. And the capacitor shall be stored under standard conditions thermal to obtain stability, after which measurements shall be made. measurement circuit(测试电路图)</p>							
			<p>VZ: 浪涌电压 Surge voltage V1: 直流电压 DC voltage R1: 保护电阻 (1KΩ) Protective resistor R2: 放电电阻 Discharge resistor CX: 测试电容 Test capacitor S: 开关 Switch</p>						
SPEC:		<p>1) 电容量变化 Change in capacitance: ±10%初时值以内 Within ±10% of the initial value 2) 损耗正切值 tangent of the loss angle: 小于等于初时值 The initial specified value 3) ESR (equivalent series resistance): 小于等于初时值 The initial specified value or less 4) 漏电流 leakage current: 小于等于初时值 The initial specified value or less</p>							
电压设定:		RATED VOLTAGE (V_{DC})	25V						
		SURGE VOLTAGE (V_{DC})	28.7						
2	端子强度	1) 拉力(tensile)	<table border="1"> <thead> <tr> <th>d(mm)</th> <th>[N]</th> <th>Duration time</th> </tr> </thead> <tbody> <tr> <td>0.6</td> <td>10</td> <td>10±2sec(秒)</td> </tr> </tbody> </table>	d(mm)	[N]	Duration time	0.6	10	10±2sec(秒)
		d(mm)	[N]	Duration time					
0.6	10	10±2sec(秒)							
2) 抗弯强度 (Bending)	<p>端子应该在每一个方向上折弯一次，总共两次 The terminal shall be subjected to 1 bend in each direction to give a total 2 bends.</p> <table border="1"> <thead> <tr> <th>d(mm)</th> <th>[N]</th> </tr> </thead> <tbody> <tr> <td>0.6</td> <td>5.0 (0.51KG)</td> </tr> </tbody> </table> <p>端子没有破损或松动 SPEC: No breaking and loosening of terminal</p>		d(mm)	[N]	0.6	5.0 (0.51KG)			
d(mm)	[N]								
0.6	5.0 (0.51KG)								

富仕达电子科技有限公司 FSD-CON ELECTRONICS TECHNOLOGY CO.,LTD

3	可焊性 Solderability	焊料(Solder) : H60A. H60S or(或)H63A
		焊接温度(Solder temperature) : 245±2℃
		浸入时间(Immersion time) : 3±0.5sec(秒)
		浸入深度(Immersion depth) : 离本体 1.5~2mm
		熔化: 松香在酒精的浓度是25% Flux: 25% by weight of rosin in ethanol
		从含浸处到顶部, 至少有3/4部分覆盖有新焊料
		SPEC:1)3/4 of the circumference of the surface up to the immersed shall be covered with
		new solder.
4	耐焊接热 Resistance to soldering heat	焊料: (Solder) : H60A.H60S or (或) H63A
		焊接温度(Solder temperature) : 350±10℃ (or350±10℃)
		浸入时间(Immersion time) : 10±1sec(秒) (or 或 3.5±0.5sec)
		绝热遮罩板的厚度 (Thickness of heat shunt:1.6mm) : 1.6mm
		SPEC: 1)电容量变化Change in capacitance: ±10%初时值以内Within±10%of the initial value
		2)损耗正切角tangent of the loss angle:小于等于初始规定值The initial specified value or less
		3)ESR (equivalent series resistance) : 小于等于初时值The initial specified value or less
4)漏电流leakage current: 小于等于初时值The initial specified value or less		
5	表示耐溶剂性	标示应清晰可见 试剂: 乙丙醇, 浸入时间30±0.5sec
6	高温高湿 Dampheat, steady state	电容器在温度60±2℃, 相对湿度90%到95%条件下存放240±8个小时, 然后在标准条件下放1到2小时后进行测量。the capacitor shall be stored at a temperature of 60±2℃ and relative humidity of 90 to 95% for 240±8hours. And then the capacitor shall be subjected to standard atmospheric conditions for 1 to 2hours, after which measurements shall be made.
		SPEC: 1)电容量变化Change in capacitance: ±20%初时值以内Within±20%of the initial value
		2)损耗正切角tangent of the loss angle:150%初始值规定以内within ±150%of the initial value
		3)ESR (equivalent series resistance) : 150%初始值规定以内within ±150%of the initial value
		4)漏电流leakage current: 小于等于初时值The initial specified value or less
7	高温储存 Shelf life	在+125温度下不外加电压储存, 电容器存放1000小时。然后在标准条件下放1到2小时进行测量, 并且在测漏电流前, 必须满足以上条件。The capacitor shall be stored at +125℃ temperature specified below for 1000 hours. During which time no voltage shall be applied. And then the capacitor shall be subjected to standard atmospheric conditions for 1 to2hours, after which measurements shall be made, Prior to the measurement of leakage current, following conditioning may be made.
		SPEC: 1):电容量变化Change in capacitance: ±20%初时值以内Within±20%of the initial value
		2)损耗正切角tangent of the loss angle:150%初始值规定以内within ±150%of the initial value
		3)ESR (equivalent series resistance) : 150%初始值规定以内within ±150%of the initial value
		4)漏电流leakage current: 小于等于初时值The initial specified value or less

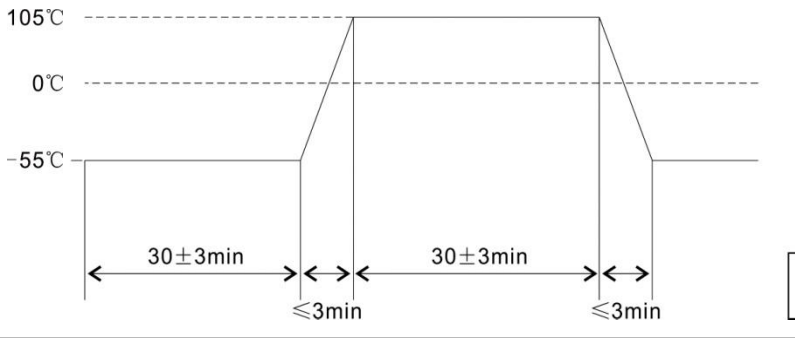
8	耐久性 load life	<p>在+125℃下，电容器施加带纹波电流的额定电压3000小时。在标准条件下放1到2小时后进行测量。The rated voltage with specified ripple current shall be applied continuously to the capacitor at maximum operating temperature +125℃ for 3000 hours. And then the capacitor shall be subjected to standard atmospheric conditions for 1to 2hours, after which measurement shall be made.</p> <p>SPEC: 1)电容量变化Change in capacitance: ±20%初时值以内Within±20%of the initial value 2)损耗正切角tangent of the loss angle:150%初始值规定以内within ± 150%of the initial value 3)ESR（equivalent series resistance）：150%初始值规定以内within ± 150%of the initial value 4)漏电流leakage current: 小于等于初时值The initial specified value or less.</p>
9	温度循环测试 Rapid temperature change	<p>电容器要在图1的温度循环要求下保持5个循环，然后在标准条件下放1-2个小时后进行测量。The characteristics of a capacitor kept under the temperature cycle indicated in Figure1 for 5 cycles . And then the capacitor shall be subjected to standard atmospheric conditions for 1to 2hours, after which measurement shall be made</p>  <p>SPEC: 1)电容量变化Change in capacitance: ±10%初时值以内Within±10%of the initial value 2)损耗正切角tangent of the loss angle:小于等于初时值The initial specified value or less 3)ESR（equivalent series resistance）：小于等于初时值The initial specified value or less 4)漏电流leakage current: 小于等于初时值The initial specified value or less.</p>
10	低温测试 Low temperature test	<p>电容器要在温度-55℃条件下存放72±2个小时。然后在标准条件下放1到2个小时进行测试。the shall be stored at a temperature of -55℃ for 72±2hours. And then the capacitor shall be subjected to standard atmospheric conditions for 1 to 2hours, after which measurements shall be made</p> <p>SPEC: 1)电容量变化Change in capacitance: ±10%初时值以内Within±10%of the initial value 2)损耗正切角tangent of the loss angle:小于等于初时值The initial specified value or less 3)ESR（equivalent series resistance）：小于等于初时值The initial specified value or less 4)漏电流leakage current: 小于等于初时值The initial specified value or less.</p>
11	ON-OFF实验	<p>在40±2℃的环境下，电压5V叠加纹波电流3A，通电10S，停1S，开关机，循环10000次。The capacitor shall be subjected to 10000 cycles with voltage 5V & ripple 3A current at maximum operating temperature +40±2℃. each consisting of a charge period of 10sec, followed by a discharge period of approx. 1sec</p> <p>SPEC: 1)电容量变化Change in capacitance: ±10%初时值以内Within±10%of the initial value 2)损耗正切角tangent of the loss angle:小于等于初时值The initial specified value or less 3)ESR（equivalent series resistance）：小于等于初时值The initial specified value or less 4)漏电流leakage current: 小于等于初时值The initial specified value or less.</p>

五：结构图

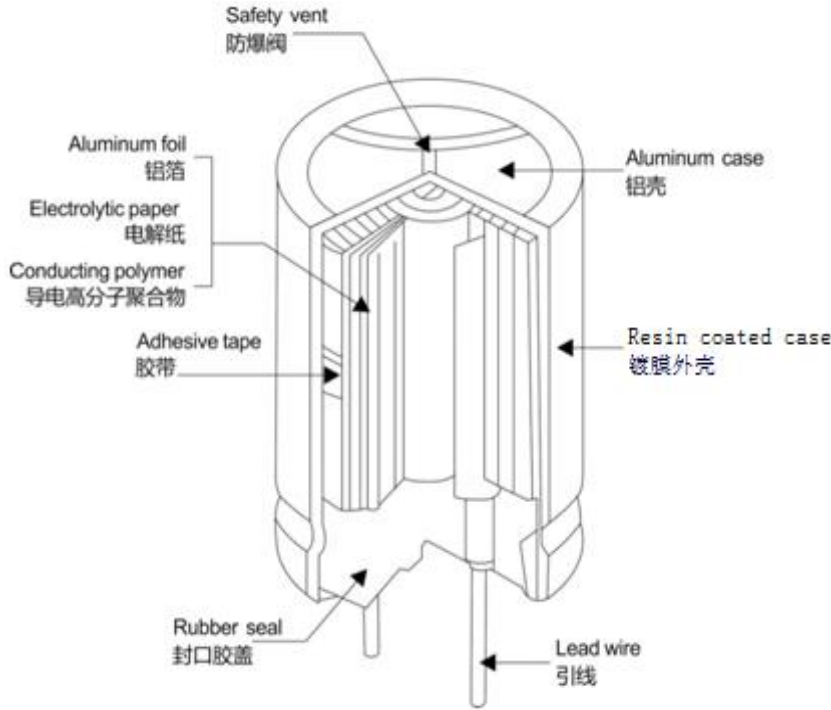

六：标志 Marking

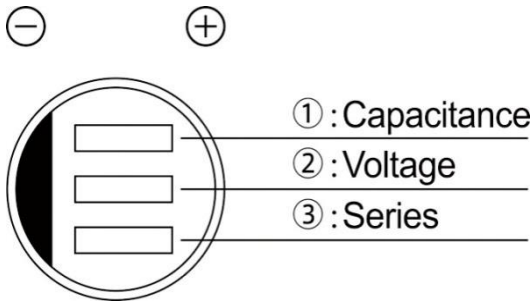

1,	代表容量 Rate Capacitance
2,	代表电压 Rate Voltage
3,	代表系列号 Series

七：包装 Packing

包装标签标示 Packing Label Marked

(下面项目应该体现在标签上 The following items shall be marked on the label)

(外箱 outer carton)

系列、额定容值、额定电压	Series、Rate Capacitance、Rate Voltage
尺寸	Size
数量	Quantity
物料编码	P/N
批号	LOT Number

Example: 示例:

ITEM: PB 1000UF6.3V SIZE: 6.3X11L QTY: 16,000pcs P/L: EPPB0J102M6311BS NL: FSD20 180820-01 	FSD-CON ®
--	----------------------

■ In-box&outer carton 内盒和外箱

Small Box Size 内箱尺寸			Carton Box Size 外箱尺寸		
L(mm)	H(mm)	W(mm)	L(mm)	H(mm)	W(mm)
340	53	300	360	300	325

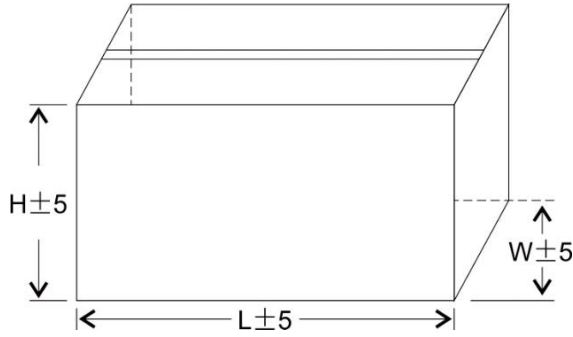

◆ Minimum package quantity.

◆ 最小包装数量。

FSD-CON P.N	Bag (pcs)	In-box (pcs)	Carton (pcs)
EPPR1E471M6314TS	2000	\	10000

◆ 包装装箱图。

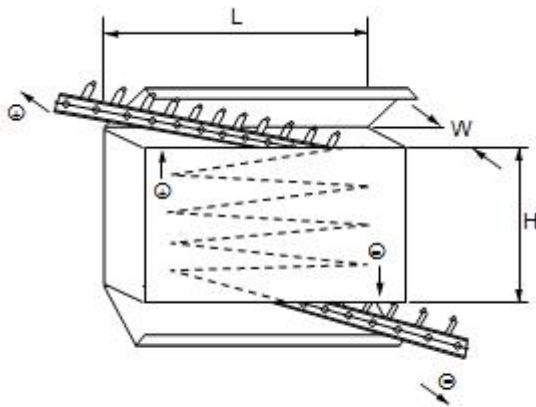

Lead Taping for Automatic Insertion 自動插件用引線編帶模式

(Drawing A) 圖 A

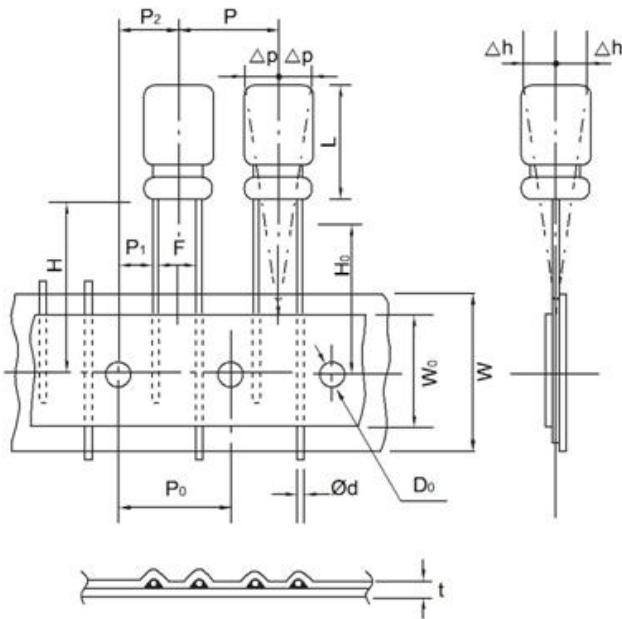

(Drawing B) 圖 B

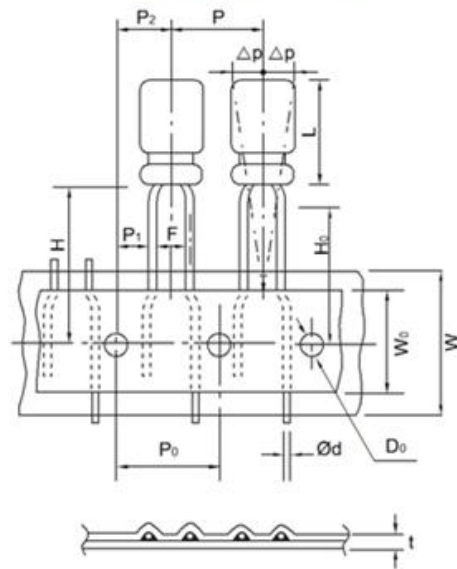

Lead Taping for Automatic Insertion 自動插件用引線編帶模式

Application To Drawing 對應外形圖			B ⁽¹⁾		A ⁽¹⁾			
Descriptions 內容	Symbol 符號	Tolerance 允差	Ø5		Ø6.3		Ø8	Ø10
Case Height 錫殼高度	L	Note ⁽²⁾	7, 8, 9	11	6, 8, 9	10.5, 11.5	7, 8, 9, 11, 12	8, 10, 13
Lead Wire Diameter 引線直徑	Ød	±0.05	0.5	0.5	0.5, 0.6, 0.6	0.6	0.6	0.6
Body Pitch 電容器本體間距	P	±1.0	12.7		12.7		12.7	12.7
Feeding Hole Pitch 運送孔間距	P ₀	±0.2	12.7		12.7		12.7	12.7
Feeding Hole Center to Lead 運送孔至引線寬度	P ₁	±0.7	5.1		5.1		5.1	3.85
Feeding Hole Alignment 運送孔至電容器本體寬度	P ₂	±1.0	6.35		6.35		6.35	6.35
Lead Center Spacing 引線間距	F	+0.8 -0.2	2.5		2.5		3.5	5.0
Tape Width 紙帶寬度	W	±0.5	18.0		18.0		18.0	18.0
Adhesive Tape Width 熱熔膠帶寬度	W ₀	Min.	10.0		9.5		9.5	12.5
Length from Seating Plane 電容器本體至紙帶中心高度	H	±0.75	17.5	18.5	17.5		18.5	18.5
Lead Clinch Height 引線彎曲至運送孔高度	H ₀	±0.5	17.0		—		—	—
Feeding Hole Diameter 運送孔直徑	ØD ₀	±0.2	4.0		4.0		4.0	4.0
Total Tape Thickness 紙帶與膠帶的總厚度	t	±0.3	0.7		0.7		0.7	0.7
Body Inclination 電容器本體傾斜度	Δh	Max.	1.0		1.0		1.0	1.0
Body Inclination 電容器本體傾斜度	Δp	Max.	1.0		1.0		1.0	1.0
Taping Code 編帶代碼			TS		TS		TS	TS

八、	<p>铝电解电容使用注意事项。Guidelines For Using Aluminum Electrolytic Capacitor.</p> <p>为了使你获得电解电容的最佳性能和延长电解电容的使用寿命，在使用电解电容前，请务必阅读本注意事项。</p> <p>Upon using Aluminum Electrolytic Capacitors, please proper handing and observing to following important points will insure optimum capacitor performance and long life.</p>
1	<p>直流电解电容是有极性的。DC electrolytic capacitors are polarized.</p> <p>确定极性，极性标志在电容器的基体上。以免因极性反可能引起电路短路或电容器损坏，当极性不固定或不确定的，使用无极性电容器。注意直流电容器不能用于交流。Make sure of the polarity. The polarity is marked to on the body of the capacitor .Application of the reversed voltage cause a short circuit or damage the capacitor. Use bipolar capacitors when the polarity is not determined or unknown. Note that DC electrolytic capacitors can not be used for AC application.</p>
2	<p>使用电压不要大于额定电压。Do not apply voltage Higher than rated voltage.</p> <p>使用电压大于额定电压，漏电流会增大，可能损坏电容器。建议工作电压为额定电压的70%-80%，电容器在建议工作电压下使用可以延长电容器的寿命。If a voltage exceeding the rated voltage is applied, the leakage current will increase, which damage the capacitor. Recommended working voltage is 70 to 80 percent of tatted voltage. Using capacitors at recommended working voltage prolongs capacitor life.</p>
3	<p>不要使用过量纹波电流通过电容器。Do not allow excessive ripple current through the capacitor.</p> <p>流过电容器的纹波电流超过许可值，将会引起电容器发热，电容量减少，损耗电容器。通过电容器的纹波电流不要大于允许值。The flow of ripple current over permissible ripple current will cause heat of the capacitor, which may decrease the capacitance and damage the capacitor. Ripple current on the capacitor must be at or bellow allowable level.</p>
4	<p>快速充放电电路中，使用专门设计的电容器。Use specially designed capacitors for the circuits where charge and discharge are frequency repeated.</p> <p>在经受快速的周期性充放电电路中，电容器可能收到损害，它的寿命因容量下降、温升等原因而缩短，在这种电路中，一定要使用专门设计的电容器。In the circuit subjected to rapid charge cycles, capacitors may be damaged, its life may be shortened by capacitance decrease, heat rise, ect. Be sure and use special capacitors in these applications.</p>
5	<p>工作温度范围。Operating temperature range.</p> <p>电容器的特性随工作温度变化而变化，在温度较高的情况下，容量，漏电流增大，损耗减少；在低温情况下，容量和漏电流下降，损耗增大。电容器在较低温度下使用会确保延长寿命。The characteristics of capacitors change with the operating temperature. The capacitance and leakage current increase and tgδ decrease at higher temperatures. The capacitance and leakage current decrease and tgδ at increase lower temperature. Usage at lower temperature will ensure longer life.</p>
6	<p>核对工作频率。Check operating frequency.</p> <p>电解电容器的容量通常是在100HZ或者120HZ下测得的。然而要记住容量随频率的升高而下降，tan δ 随频率的升高而增大，并使周围温度升高。The capacitance of electrolytic capacitors is usually measured at 100Hz or 120Hz. However, remember that capacitance decrease and tgδ increase as the applied frequency becomes higher whereas the ambient temperature becomes higher.</p>
7	<p>长时间存放的电容器，在使用前加额定直流电压处理。</p> <p>Apply rated DC voltage treatment to the capacitors which have been stored for a long time.</p> <p>长时间的存放，实际对电容器的容量和tan δ 没有多大的影响，然而往往会使漏电流增大，耐压降低。长时间存放后的电容器处理，首先逐渐施加直流电压至额定电压，然后再使用。Long periods of storage have virtually no effect on a capacitor's capacitance and tgδ. Such periods tend however, to increase leakage current and decrease withstand voltage. After removing capacitors from long-duration storage, first apply a gradually increasing DC voltage to rated voltage and then use them.</p>
8	<p>固态电容器的外壳为镀膜外壳，与极性是绝缘的。The Case of Conductive Polymer Aluminum Solid Electrolytic Capacitor is Resin coated case which is insulated with the terminals.</p>

9	The capacitor's case and cathode terminal connect through the electrolyte. If the case is to be completely
	insulated, that insulation must be at the capacitor's mounting point.
10	电容器的端子或者引线上不要施加过大的力。
	Do not apply excessive force to the terminals and leads.
	过大的力施加到端子和引线上，可能引起引线的断裂或端子分裂，转而会引起内部链接的破坏
	The excessive strong force applied to the terminals and lead wires may cause leads to break or
	terminals to separate and, in turn, cause the internal contact to fail.

有害物质目录表

Hazardous substances management table of contents

区分 Type	物质名称 (中文名) Name(chinese)	物质名称(英文名) Name(English)	有害物质包含与否 (Test result)	
			有 Yes	无 No
Level A- I	铅以及它的化合物	Lead and its compounds	14PPM	
	镉以及它的化合物	Cadmium and its compounds		NO
	水银以及它的化合物	Mercury and its compounds		NO
	六价铬以及它的化合物	Hexavalent chromium and its compounds		NO
	多溴化的联苯	Polybrominated biphenyls		NO
	聚溴二苯醚	Polybrominated diphenylethers		NO
Level A- II	多氯化联苯 (PCB)	Polybrominated biphenyls (PCB)		NO
	多氯化萘 (PCN)	Polybrominated naphthalenes(PCN)		NO
	三磷酸盐	Polybrominated terphenyls(PCT)		NO
	氯化涂石蜡 (SCCP)	Short-chain chlorinated paraffins(SCCP)		NO
	石棉以及它的化合物	Asbestos and its compounds		NO
	臭氧层破坏物质	Ozone Depleting Substances		NO
	偶氮化合物	Azo compounds		NO
	镍以及它的化合物	Specific organic tin compounds		NO
	有机锡类化合物	Nickel and its compounds		NO
	砷以及它的化合物	Specific organic tin compounds		NO
	甲醛	Formaldehydes		NO
Level B	氯化乙烯树脂	Polyvinyl chloride,(PET)		NO
	磷苯二甲酸盐	Phthalates		NO
	铍以及他的化合物	Beryllium and its compounds		NO
	锑及其它的化合物	Antimony and its compounds		NO
	硒及其它的化合物	Selenium and its compounds		NO
	钯及其它的化合物	Palladium and its compounds		NO
	铋及其化合物	Bismuth and its compounds		NO
	其他氯类难燃试剂	Other chlorinated flame retardants		NO
	其他溴类难燃试剂	Other brominated flame retardants		NO
Note:	<p>1, 原则上按照公司的管理规定, 但由管理总部提出根据Buyer等交易商的要求制定的另行有害物质管理目录来执行的要求时, 应优先按照管理总部的管理目录来记载。</p> <p>2, 确认合作企业现在是否在使用这类物质, 应记录使用与否。</p>			