

深圳市索瑞达电子有限公司

承 认 书

SPECIFICATION FOR APPROVAL

客户名称: 标准
Customer Name : _____

客户料号:
Customer P/N: _____

产品名称: 功率电感
Product Name: _____

索瑞达料号: SNR.4012-系列
Sorede P/N: _____

制造厂商 Manufacturer	
拟制 Draft	黄小香
审核 Check	符妃团 工程专用章
日期 Date	2018-6-6

客户承认印章 Approval Signet	
日期 Date	

地址: 深圳市观澜镇福城街道新塘村8号源创园陆号A6栋3楼.

Address: 3Rd Floor, Building A6, Yuanchuangyuanlu, No. 8 Xintang Village, Fucheng Street, Guanlan Town, Shenzhen.

电话 Tel: 0755-29803356 传真 Fax: 0755-29803506

电子邮件 E-mail: sorde@vip.163.com

网址 [http:// www.szsorede.com](http://www.szsorede.com)

文件编号 File Number	SRD-WI-3627	版本号 Version Number	A	页码 page	1/3
---------------------	-------------	-----------------------	---	------------	-----

1、外形尺寸 Dimension :

单位Unit: mm

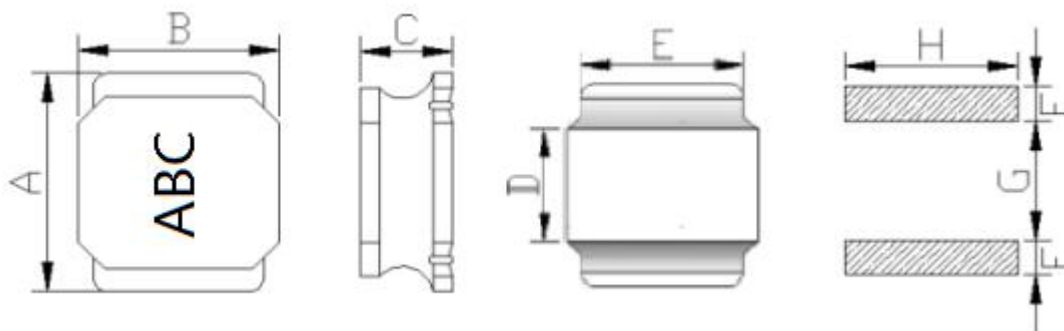

A	4.00±0.2
B	4.00±0.2
C	1.2 Max
D	1.8Ref.
E	3.3Ref
F	1.3Ref
G	1.8Ref.
H	3.7Ref

2、产品品名构成 Product Spec. Model

SR 4012T Y D - 2R2 M

a b c d e f

a: 系列名称 Series name

b: 产品尺寸 Product dimensions (A x B x C)

c: 密封方式 Sealing way (L: 冷封 Cold seal Y: 热封 Heat seal)

d: 印字方向 Lettering direction ▶

e: 电感值 Inductance Value

(1R0:1.0uH; 100: 10uH; 101:100uH)

f: 电感公差 Inductance Tolerance (K:10% ; M:20% ; N:30%)

▶ Lettering direction

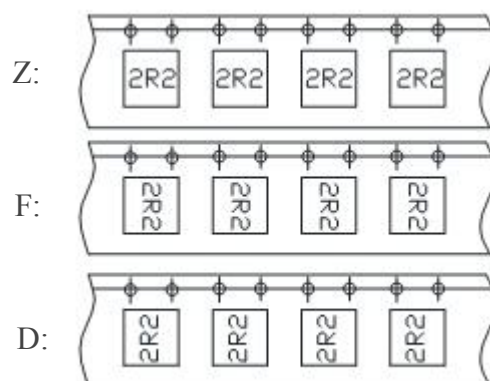

3、结构 Structure

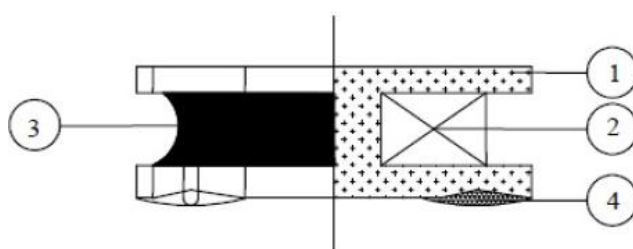

4、材料清单 MATERIAL LIST

NO.	PARTS	MATERIAL	UL FILE NO.	TEMP. CLASS
1	CORE	Ni-Zn CORE OR EQUIVALENT	NA	NA
2	WIRE	POLYURETHANE ENAMELLED COPPER WIRE OR EQUIVALENT	E258243	180°C
3	ADHESIVE	EPOXY RESIN OR EQUIVALENT	NA	NA
4	SOLDER	Sn99.3-Cu0.7 OR EQUIVALENT	NA	NA

*NA:NOT APPLICABLE.

文件编号 File Number	SRD-WI-3627	版本号 Version Number	A	页码 page	2/3
---------------------	-------------	-----------------------	---	------------	-----

5、电性能参数表 Electrical Characteristics List

规格型号 Part NO.	电感量 Tolerance(μ H)	测试频率 Test Freq. (kHz/v)	直流电阻 DC Max (Ω)	饱和电流 Isat (A)	温升电流 Irms (A)
SNR.4012.BYDR68NT00	0.68	100/0.25	0.058	3.20	1.72
SNR.4012.BYD1R0NT00	1.0	100/0.25	0.065	2.61	1.65
SNR.4012.BYD1R5NT00	1.5	100/0.25	0.094	2.50	1.46
SNR.4012.BYD2R2MT00	2.2	100/0.25	0.105	2.10	1.32
SNR.4012.BYD3R3MT00	3.3	100/0.25	0.149	1.80	1.12
SNR.4012.BYD4R7MT00	4.7	100/0.25	0.198	1.20	1.05
SNR.4012.BYD6R8MT00	6.8	100/0.25	0.286	1.18	0.84
SNR.4012.BYD100MT00	10	100/0.25	0.442	0.95	0.77
SNR.4012.BYD150MT00	15	100/0.25	0.651	0.80	0.64
SNR.4012.BYD220MT00	22	100/0.25	1.01	0.65	0.49
SNR.4012.BYD330MT00	33	100/0.25	1.28	0.55	0.42
SNR.4012.BYD470MT00	47	100/0.25	2.21	0.45	0.37

※公差Tolerance: N: \pm 30%、M: \pm 20%、K: \pm 10%.

※工作温度Operating temperature rang: -40 $^{\circ}$ C to +125 $^{\circ}$ C (Including Self-heating)

※储存温度Storage temperature rang: -40 $^{\circ}$ C to +125 $^{\circ}$ C

额定电流: 指使电感量比初始值下降30%或电感器表面温度上升 40 $^{\circ}$ C 的电流值 (参考周围环境温度 25 $^{\circ}$ C)。
The rated DC current is that which cause at 30% inductance reduction from the initial value or inductor surface temperature to rise by 40 $^{\circ}$ C , whichever is smaller (Reference ambient temperature 25 $^{\circ}$ C)。

6、产品包装 Packaging

1) 载带包装示意图 Tape packing diagram

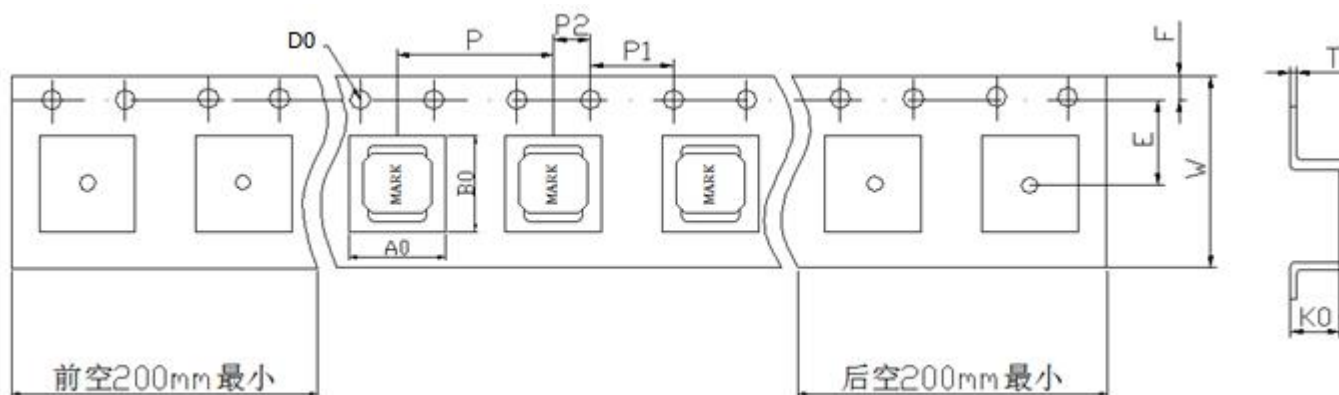

ITEM	W	A0	B0	K0	P	E	F	D0	P0	P2	T
DIM	12.00	4.30	4.30	1.40	8.00	5.50	1.75	1.50	4.00	2.00	0.30
TOLE	±0.3	±0.1	±0.1	±0.1	±0.1	±0.1	±0.1	+0.1	±0.1	±0.1	±0.05

2) 卷盘包装示意图 Tape packing diagram

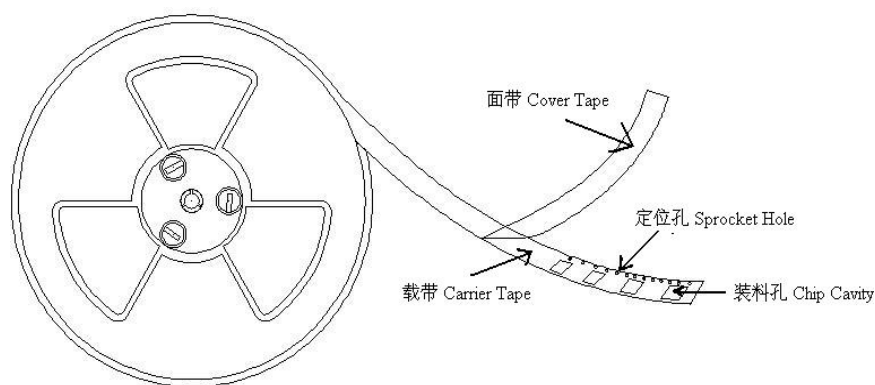

3) 剥离强度要求 Peeling required

- ① F 力大小: 20~100g;
- ② 面带剥离角度: 165°~180°。



4) 包装数量 Packing quantity

项目	数量 (PCS)	尺寸规格 (mm)
盘	4500	13"
内盒	18000	340mm*340mm*65mm
外箱	36000	360mm*360mm*160mm