

深圳市索瑞达电子有限公司

承 认 书

SPECIFICATION FOR APPROVAL

客 户 名 称：标 准
Customer Name : _____

客 户 料 号：
Customer P/N: _____

产 品 名 称：功 率 电 感
Product Name: _____

索 瑞 达 料 号：
Sorede P/N: SNR8040-系列 _____

制造厂商 Manufacturer	
拟制 Draft	黄小香
审核 Check	符妃团 工程专用章
日期 Date	2018-6-6

客户承认印章 Approval Signet	
日期 Date	

地址:深圳市观澜镇福城街道新塘村8号源创园陆号A6栋3楼.

Address:3Rd Floor, Building A6, Yuanchuangyuanlu, No. 8 Xintang Village,
Fucheng Street, Guanlan Town, Shenzhen.

电话 Tel: 0755-29803356 传真 Fax: 0755-29803506

电子邮件 E-mail: sorde@vip.163.com

网址 [http:// www.szsorede.com](http://www.szsorede.com)

文件编号 File Number	SRD-WI-3638	版本号 Version Number	A	页码 page	1/4
---------------------	-------------	-----------------------	---	------------	-----

1、外形尺寸 Dimension :

单位Unit: mm



A	8.00±0.3
B	8.00±0.3
C	4.2Max.
D	3.5±0.3
E	6.3Ref
F	2.5Ref
G	3.4Ref
H	7.5Ref

2、产品品名构成 Product Spec. Model

SR 8040T Y D - 2R2 N

a b c d e f

- a: 系列名称 Series name
- b: 产品尺寸 Product dimensions (A x B x C)
- c: 密封方式 Sealing way (L: 冷封 Cold seal Y: 热封 Heat seal)
- d: 印字方向 Lettering direction ▶
- e: 电感值 Inductance Value
(1R0:1.0uH; 100: 10uH; 101:100uH)
- f: 电感公差 Inductance Tolerance (K:10% ; M:20% ; N:30%)

▶ Lettering direction



3、结构 Structure

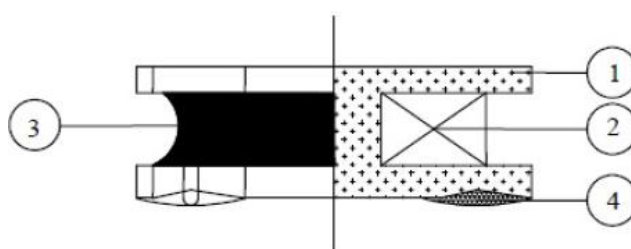

4、材料清单 MATERIAL LIST

NO.	PARTS	MATERIAL	UL FILE NO.	TEMP. CLASS
1	CORE	Ni-Zn CORE OR EQUIVALENT	NA	NA
2	WIRE	POLYURETHANE ENAMELLED COPPER WIRE OR EQUIVALENT	E258243	180°C
3	ADHESIVE	EPOXY RESIN OR EQUIVALENT	NA	NA
4	SOLDER	Sn99.3-Cu0.7 OR EQUIVALENT	NA	NA

*NA:NOT APPLICABLE.

文件编号 File Number	SRD-WI-3638	版本号 Version Number	A	页码 page	2/4
---------------------	-------------	-----------------------	---	------------	-----

5、电性能参数表 Electrical Characteristics List

规格型号 Part NO.	电感量 Tolerance(μ H)	测试频率 Test Freq. (kHz/v)	直流电阻 DC Max (Ω)	饱和电流 Isat (A)	温升电流 Irms (A)
SNR.8040.TYD1R0NT00	1.0	100/0.25	0.011	9.80	6.30
SNR.8040.TYD1R5NT00	1.5	100/0.25	0.014	7.70	5.65
SNR.8040.TYD2R2NT00	2.2	100/0.25	0.016	7.10	5.15
SNR.8040.TYD2R6NT00	2.6	100/0.25	0.017	7.10	5.10
SNR.8040.TYD3R3NT00	3.3	100/0.25	0.022	6.50	4.40
SNR.8040.TYD3R6NT00	3.6	100/0.25	0.024	6.30	4.35
SNR.8040.TYD3R9NT00	3.9	100/0.25	0.024	6.30	4.35
SNR.8040.TYD4R7NT00	4.7	100/0.25	0.026	5.90	4.10
SNR.8040.TYD5R6NT00	5.6	100/0.25	0.031	5.50	3.85
SNR.8040.TYD6R8MT00	6.8	100/0.25	0.036	4.50	3.60
SNR.8040.TYD8R2MT00	8.2	100/0.25	0.046	4.20	3.45
SNR.8040.TYD100MT00	10	100/0.25	0.048	3.60	3.30
SNR.8040.TYD120MT00	12	100/0.25	0.065	3.40	2.80
SNR.8040.TYD150MT00	15	100/0.25	0.073	2.90	2.60
SNR.8040.TYD180MT00	18	100/0.25	0.092	2.70	2.40
SNR.8040.TYD220MT00	22	100/0.25	0.096	2.40	2.10
SNR.8040.TYD270MT00	27	100/0.25	0.101	2.15	2.00
SNR.8040.TYD330MT00	33	100/0.25	0.130	2.00	1.80
SNR.8040.TYD390MT00	39	100/0.25	0.163	1.95	1.70
SNR.8040.TYD470MT00	47	100/0.25	0.210	1.70	1.55
SNR.8040.TYD510MT00	51	100/0.25	0.230	1.60	1.50
SNR.8040.TYD680MT00	68	100/0.25	0.255	1.40	1.25
SNR.8040.TYD820MT00	82	100/0.25	0.345	1.20	1.15
SNR.8040.TYD101MT00	100	100/0.25	0.384	1.12	1.00
SNR.8040.TYD121MT00	120	100/0.25	0.421	1.08	0.95
SNR.8040.TYD151MT00	150	100/0.25	0.611	1.05	0.85
SNR.8040.TYD181MT00	180	100/0.25	0.806	0.95	0.83

※公差Tolerance: N: \pm 30%、M: \pm 20%、K: \pm 10%.

※工作温度Operating temperature rang: -40 $^{\circ}$ C to +125 $^{\circ}$ C (Including Self-heating)

※储存温度Storage temperature rang: -40 $^{\circ}$ C to +125 $^{\circ}$ C

额定电流: 指使电感量比初始值下降30%或电感器表面温度上升 40 $^{\circ}$ C的电流值 (参考周围环境温度 25 $^{\circ}$ C)。

The rated DC current is that which cause at 30% inductance reduction from the initial value or inductor surface temperature to rise by 40 $^{\circ}$ C, whichever is smaller (Reference ambient temperature 25 $^{\circ}$ C)。

文件编号 File Number	SRD-WI-3638		版本号 Version Number	A	页码 page	3/4
规格型号 Part NO.	电感量 Tolerance(μH)	测试频率 Test Freq. (kHz/v)	直流电阻 DC Max (Ω)	饱和电流 Isat (A)	温升电流 Irms (A)	
SNR.8040.TYD221MT00	220	100/0.25	0.858	0.90	0.80	
SNR.8040.TYD331MT00	330	100/0.25	1.261	0.68	0.64	
SNR.8040.TYD471MT00	470	100/0.25	1.625	0.60	0.50	
SNR.8040.TYD681MT00	680	100/0.25	2.67	0.50	0.45	
SNR.8040.TYD102MT00	1000	100/0.25	3.80	0.40	0.35	
SNR.8040.TYD222MT00	2200	100/0.25	9.96	0.27	0.23	

※公差Tolerance: N:±30%、M:±20%、K:±10%。
 ※工作温度Operating temperature rang: -40 ℃ to +125℃ (Including Self-heating)
 ※储存温度Storage temperature rang: -40 ℃ to +125℃

额定电流: 指使电感量比初始值下降30%或电感器表面温度上升 40℃的电流值 (参考周围环境温度 25℃)。
 The rated DC current is that which cause at 30% inductance reduction from the initial value or inductor surface temperature to rise by 40℃, whichever is smaller (Reference ambient temperature 25℃)。

6、产品包装 Packaging

1) 载带包装示意图 Tape packing diagram

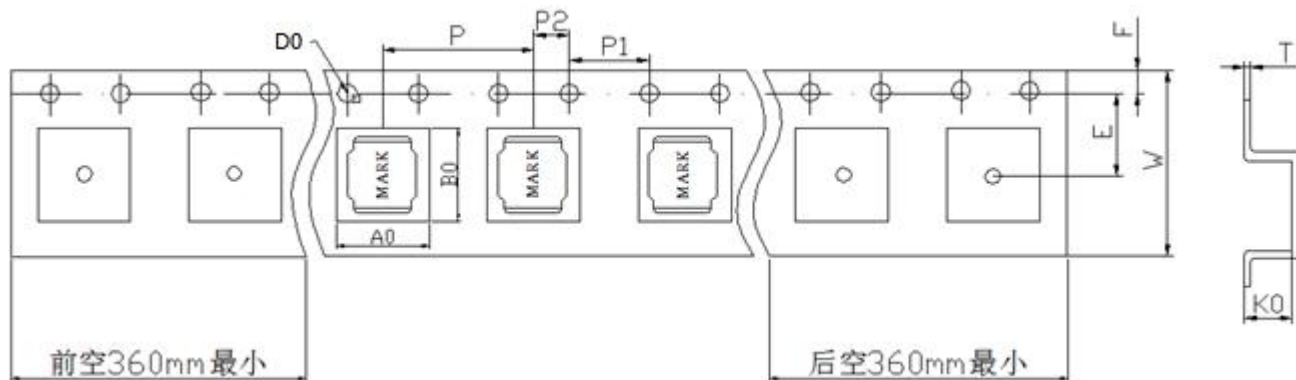

ITEM	W	A0	B0	K0	P	E	F	D0	P0	P2	T
DIM	16.00	8.40	8.40	4.50	12.00	7.50	1.75	1.50	4.00	2.00	0.40
TOLE	±0.3	±0.1	±0.1	±0.1	±0.1	±0.1	±0.1	+0.1	±0.1	±0.1	±0.05

2) 卷盘包装示意图 Tape packing diagram

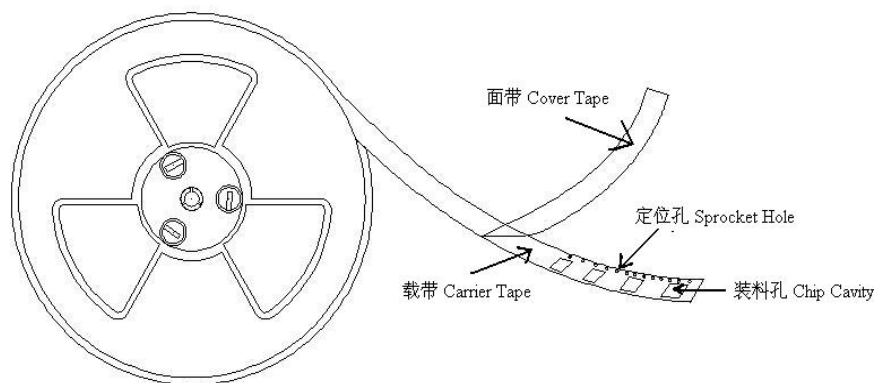

3) 剥离强度要求 Peeling required

- ① F 力大小: 20~100g;
- ② 面带剥离角度: 165°~180°。

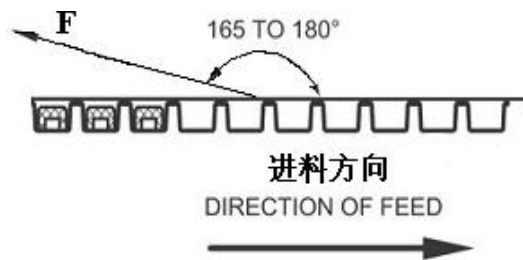

4) 包装数量 Packing quantity

项目	数量 (PCS)	尺寸规格 (mm)
盘	1000	13"
内盒	3000	340mm*340mm*65mm
外箱	6000	360mm*360mm*160mm