





文件编号 File Number	SRD-WI-5348	版本号 Version Number	A	页码 page	1/3
---------------------	-------------	-----------------------	---	------------	-----

### 1、外形尺寸 Dimension :

单位Unit: mm

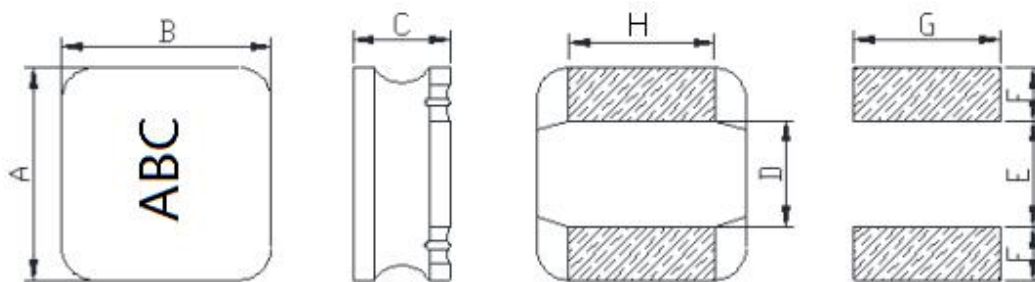

A	10.0±0.3
B	10.0±0.3
C	5.0Max.
D	6.4Ref
E	6.2Ref
F	2.0Ref
G	5.5Ref
H	4.2Ref

### 2、产品品名构成 Product Spec. Model

SR 1050T Y D - 2R2 N

a b c d e f

a: 系列名称 Series name

b: 产品尺寸 Product dimensions (A x B x C)

c: 密封方式 Sealing way (L: 冷封 Cold seal Y: 热封 Heat seal)

d: 印字方向 Lettering direction ▶

e: 电感值 Inductance Value

(1R0:1.0uH; 100: 10uH; 101:100uH)

f: 电感公差 Inductance Tolerance (K:10% ; M:20% ; N:30%)

#### ▶ Lettering direction

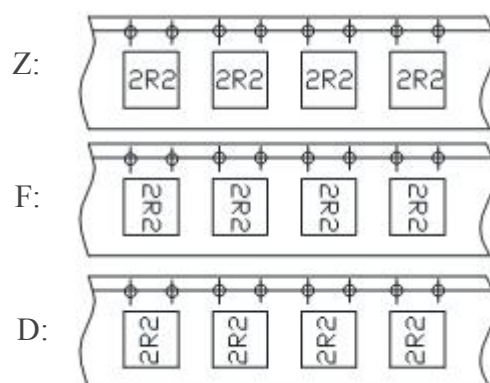

### 3、结构 Structure

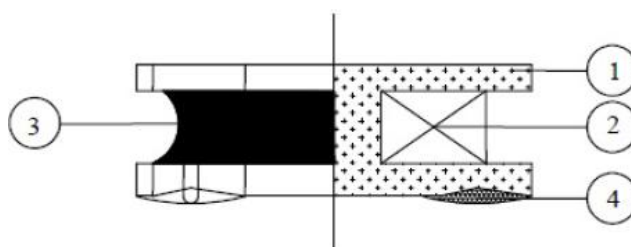

### 4、材料清单 MATERIAL LIST

NO.	PARTS	MATERIAL	UL FILE NO.	TEMP. CLASS
1	CORE	Ni-Zn CORE OR EQUIVALENT	NA	NA
2	WIRE	POLYURETHANE ENAMELLED COPPER WIRE OR EQUIVALENT	E258243	180°C
3	ADHESIVE	EPOXY RESIN OR EQUIVALENT	NA	NA
4	SOLDER	Sn99.3-Cu0.7 OR EQUIVALENT	NA	NA

\*NA:NOT APPLICABLE.

### 5、电性能参数表 Electrical Characteristics List

规格型号 Part NO.	电感量 Tolerance( $\mu$ H)	测试频率 Test Freq. (kHz/v)	直流电阻 DC Max ( $\Omega$ )	饱和电流 Isat (A)	温升电流 I <sub>rms</sub> (A)
SNR.1050.TYD1R0NT00	1.0	100/0.25	0.018	14.2	6.40
SNR.1050.TYD1R5NT00	1.5	100/0.25	0.020	12.8	6.00
SNR.1050.TYD2R2NT00	2.2	100/0.25	0.025	12.1	5.50
SNR.1050.TYD3R3NT00	3.3	100/0.25	0.027	11.2	5.00
SNR.1050.TYD4R7NT00	4.7	100/0.25	0.030	10.3	4.60
SNR.1050.TYD6R8MT00	6.8	100/0.25	0.037	9.00	4.20
SNR.1050.TYD100MT00	10	100/0.25	0.048	7.20	3.70
SNR.1050.TYD150MT00	15	100/0.25	0.059	6.00	3.20
SNR.1050.TYD220MT00	22	100/0.25	0.085	4.30	2.70
SNR.1050.TYD330MT00	33	100/0.25	0.104	4.00	2.30
SNR.1050.TYD470MT00	47	100/0.25	0.163	3.30	2.00
SNR.1050.TYD680MT00	68	100/0.25	0.235	3.00	1.80
SNR.1050.TYD101MT00	100	100/0.25	0.338	2.50	1.40
SNR.1050.TYD151MT00	150	100/0.25	0.438	2.00	1.20
SNR.1050.TYD221MT00	220	100/0.25	0.675	1.80	1.00
SNR.1050.TYD271MT00	270	100/0.25	0.858	1.50	0.90
SNR.1050.TYD331MT00	330	100/0.25	1.10	1.40	0.85
SNR.1050.TYD471MT00	470	100/0.25	1.43	1.20	0.73
SNR.1050.TYD561MT00	560	100/0.25	1.75	1.10	0.68
SNR.1050.TYD681MT00	680	100/0.25	1.98	1.00	0.65
SNR.1050.TYD821MT00	820	100/0.25	2.73	0.90	0.55
SNR.1050.TYD102MT00	1000	100/0.25	3.42	0.80	0.50

※公差Tolerance: N:±30%、M:±20%、K:±10%.

※工作温度Operating temperature rang: -40 °C to +125°C (Including Self-heating)

※储存温度Storage temperature rang: -40 °C to +125°C

额定电流：指使电感量比初始值下降30%或电感器表面温度上升 40°C的电流值（参考周围环境温度 25°C）。  
The rated DC current is that which cause at 30% inductance reduction from the initial value or inductor surface temperature to rise by 40°C, whichever is smaller (Reference ambient temperature 25°C)。

## 6、产品包装 Packaging

### 1) 载带包装示意图 Tape packing diagram

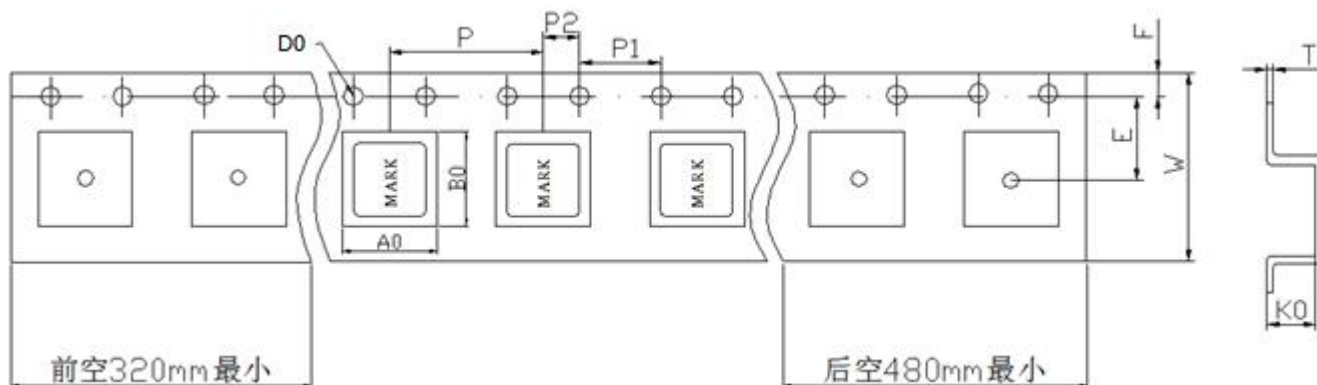

ITEM	W	A0	B0	K0	P	E	F	D0	P0	P2	T
DIM	24.00	10.4	10.4	5.2	16.00	7.5	1.75	1.50	4.00	2.00	0.40
TOLE	±0.3	±0.1	±0.1	±0.1	±0.1	±0.1	±0.1	+0.1	±0.1	±0.1	±0.05

### 2) 卷盘包装示意图 Tape packing diagram

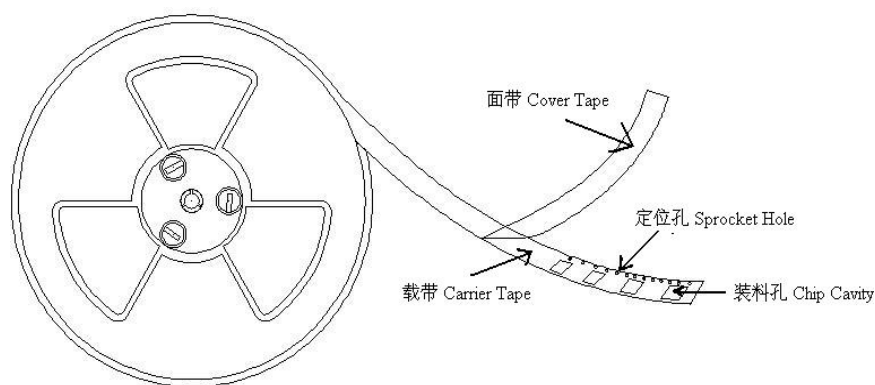

### 3) 剥离强度要求 Peeling required

- ① F 力大小: 20~100g;
- ② 面带剥离角度: 165°~180°。



### 4) 包装数量 Packing quantity

项目	数量 (PCS)	尺寸规格 (mm)
盘	800	13"
内盒	1600	340mm*340mm*65mm
外箱	3200	360mm*360mm*160mm