

Features

- * Protects one data or power line
- * Operating voltage: $\pm 5V$
- * Ultra low clamping voltage
- * Complies with following standards:
 - IEC 61000-4-2 (ESD) immunity test
 - Air discharge: $\pm 15kV$
 - Contact discharge: $\pm 8kV$

Ordering Information

Part Number	Qty per Reel	Reel Size
TPESD5L5.0CT1G	3000	7"

Mechanical Characteristics

- * Package: SOD523
- * Ultra low leakage: nA level
- * Case Material: "Green" Molding Compound.
- * UL Flammability Classification Rating 94V-0
- * Moisture Sensitivity: Level 3 per J-STD-020

Applications

- * Mobile Phones and Accessories
- * Battery Protection
- * USB VBus
- * Power Line Protection
- * Hand Held Portable Applications

Dimensions and Pin Configuration

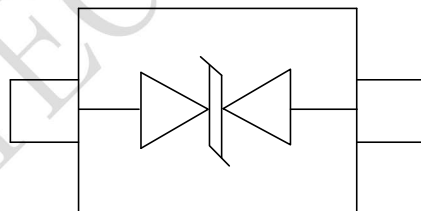

Marking: L5 *

L5 = Part code
* = Date Code

Absolute Maximum Ratings (Tamb=25°C unless otherwise specified)

Parameter	Symbol	Value	Unit
ESD per IEC 61000-4-2 (Air)	VESD	±15	kV
ESD per IEC 61000-4-2 (Contact)		±8	
Operating Temperature Range	TJ	-55 to +125	°C
Storage Temperature Range	Tstg	-55 to +150	°C

Electrical Characteristics (TA=25°C unless otherwise specified)

Parameter	Symbol	Test Condition	Min	Typ	Max	Unit
Reverse Working Voltage	V _{RWM}				5	V
Breakdown Voltage	V _{BR}	I _T = 1mA(Pin1-Pin2)	6.5		9	V
Reverse Leakage Current	I _R	V _{RWM} = 5.0V(Pin2-Pin1)			0.08	μA
Clamping Voltage	V _C	I _{PP} = 1A (8 x 20us pulse) (Pin1-Pin2)			9	V
Clamping Voltage	V _C	I _{PP} = 2A (8 x 20us pulse) (Pin1-Pin2)			15	V
Junction Capacitance	C _J	V _R = 0V, f = 1MHz (Pin1-Pin2)		0.6	0.9	pF

Characteristic Curves

Fig1. 8/20 μ s Pulse Waveform

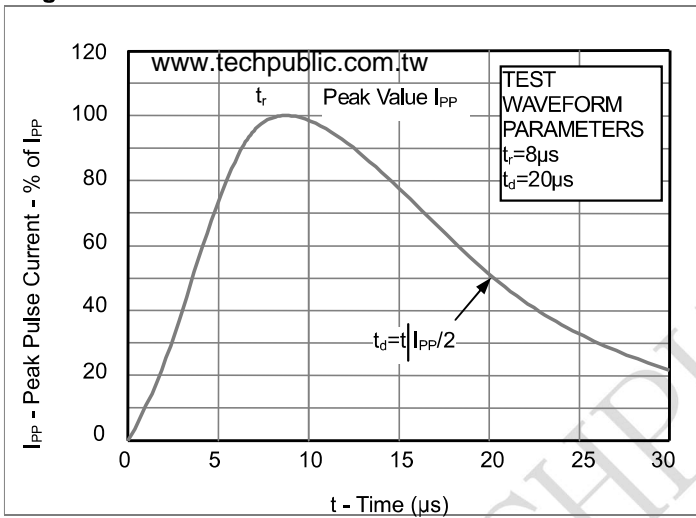

Fig2. ESD Pulse Waveform (according to IEC 61000-4-2)

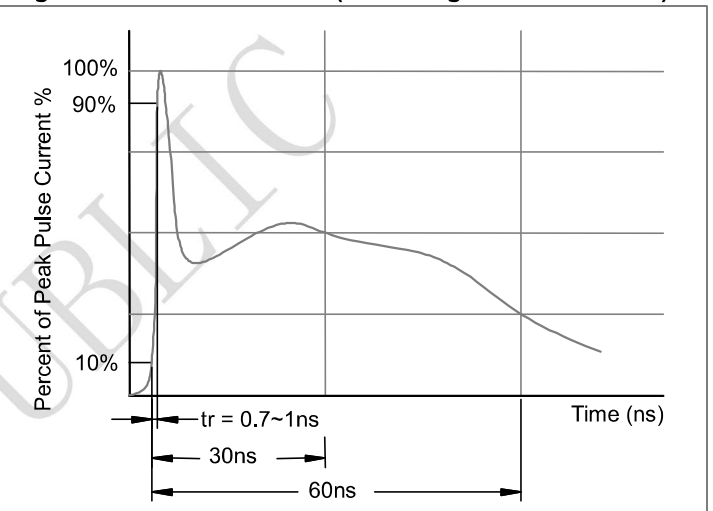
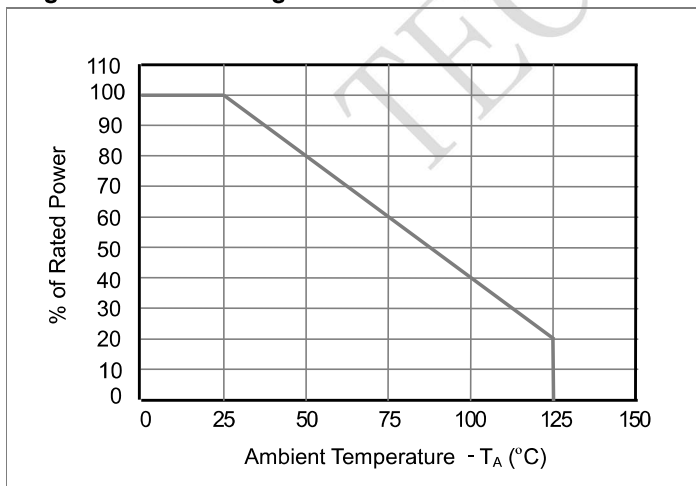
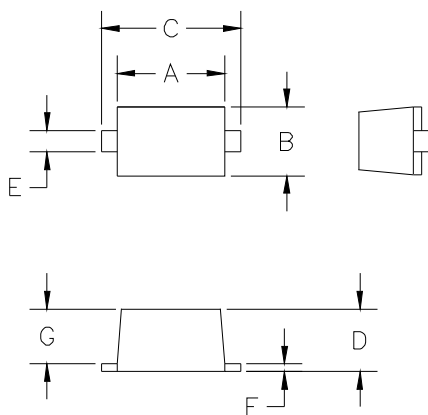

Fig3. Power Derating Curve



SOD523 (0603) Package Outline Drawing



DIM ^N	INCHES		MM [1]		NOTE
	MIN	MAX	MIN	MAX	
A	.043	.051	1.10	1.30	—
B	.028	.035	0.70	0.90	—
C	.059	.067	1.50	1.70	—
D	.020	.028	0.50	0.70	—
E	.010	.014	0.25	0.35	—
F	.004	.008	0.10	0.20	—
G	.020	.028	0.50	0.70	—

[1] CONTROLLING DIMENSION: MILLIMETERS

Suggested Land Pattern

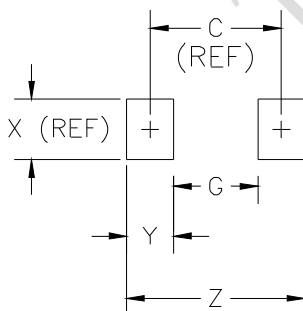

DIM ^N	INCHES		MM [1]		NOTE
	MIN	MAX	MIN	MAX	
C	—	.067	—	1.70	REF
G	—	.043	—	1.10	—
X	—	.031	—	0.80	REF
Y	—	.024	—	0.60	—
Z	—	.091	—	2.30	—

[1] CONTROLLING DIMENSION: MILLIMETERS