

Features

- Ultra small package: 0.6x0.3x0.3mm
- Ultra low capacitance: 15pF (Max)
- Ultra low leakage: nA level
- Low operating voltage: ±5V
- Low clamping voltage
- 2-pin leadless package
- Complies with following standards:
- - IEC 61000-4-2 (ESD) immunity test
Air discharge: ±30kV
Contact discharge: ±30kV
– IEC61000-4-5 (Lightning) 8 A (8/20μs)
- These are Pb-Free Devices
- Response Time is Typically < 1 ns

Ordering Information

Part Number	Qty per Reel	Reel Size
TPESD5451XZ	15000	7"

Mechanical Characteristics

- Package: DFN0603-2 (0201)
- Lead Finish: Matte Tin
- Case Material: "Green" Molding Compound.
- Moisture Sensitivity: Level 3 per J-STD-020
- Terminal Connections: See Diagram Below

Applications

- Cellular Handsets and Accessories
- Personal Digital Assistants
- Notebooks and Handhelds
- Portable Instrumentation
- Digital Cameras
- Peripherals

Dimensions and Pin Configuration

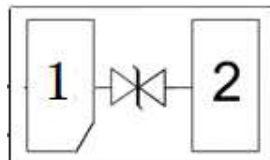

Marking:

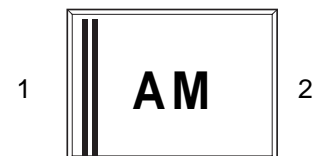

A = Part code
M = Date Code

Absolute Maximum Ratings (Tamb=25°C unless otherwise specified)

Parameter	Symbol	Value	Unit
Peak Pulse Power (8/20μs)	Ppk	80	W
Peak Pulse Current (8/20μs)	Ipp	8	A
ESD per IEC 61000-4-2 (Air)	VESD	±30	kV
ESD per IEC 61000-4-2 (Contact)		±30	
Operating Temperature Range	TJ	-55 to +125	°C
Storage Temperature Range	Tstg	-55 to +150	°C

Electrical Characteristics (TA=25°C unless otherwise specified)

Parameter	Symbol	Min	Typ	Max	Unit	Test Condition
Reverse Working Voltage	VRWM			5	V	
Breakdown Voltage	VBR	5.8	6.5		V	IT = 1mA
Reverse Leakage Current	IR			0.07	uA	VRWM = 5V
Clamping Voltage	VC			8.6	V	Ipp=1A(8x 20us pulse)
Clamping Voltage	VC			10	V	Ipp=8A(8x 20us pulse)
Junction Capacitance	CJ			17	pF	VR = 0V, f = 1MHz

Typical Performance Characteristics ($T_A=25^\circ\text{C}$ unless otherwise Specified)

Fig1. 8/20 μs Pulse Waveform

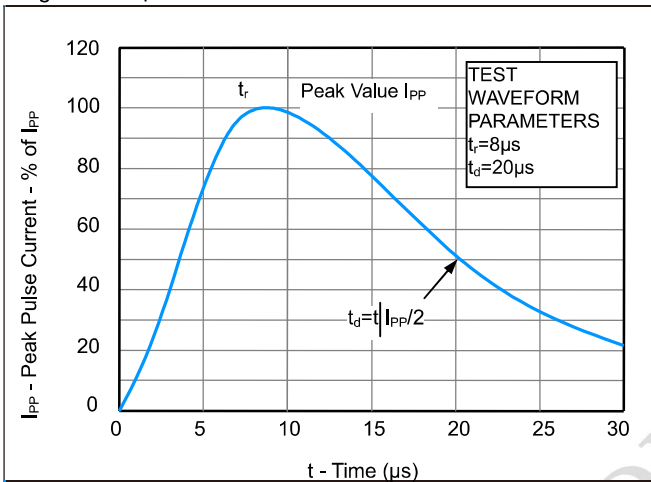

Fig2. ESD Pulse Waveform (according to IEC 61000-4-2)

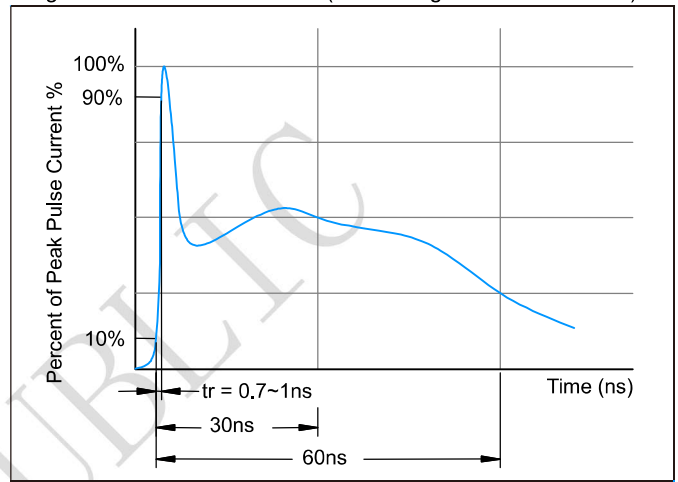
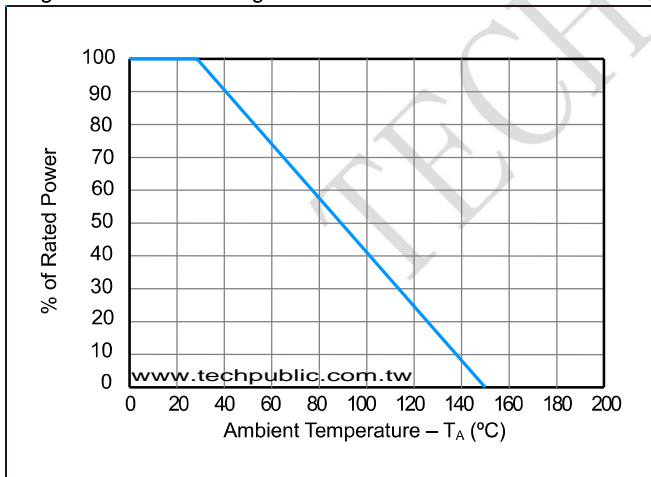
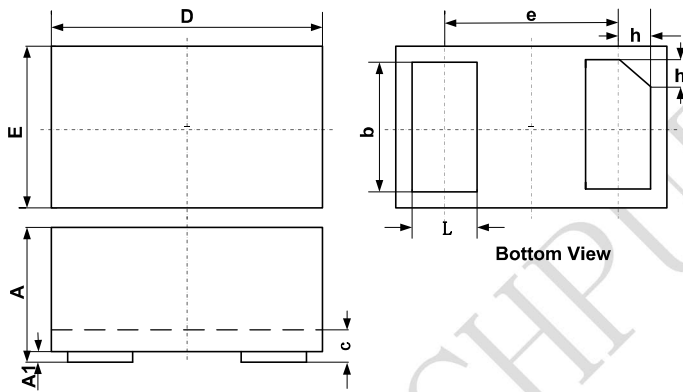

Fig3. Power Derating Curve



DFN0603-2 Package Outline Drawing (0201)



SYM	DIMENSIONS		
	MILLIMETERS		
	MIN	NOM	MAX
A	0.230	0.300	0.330
A1	0.000	0.020	0.050
b	0.215	0.245	0.275
c	0.120	0.150	0.180
D	0.550	0.600	0.650
e	0.355 BSC		
E	0.250	0.300	0.350
L	0.160	0.190	0.220
h	0.079 BSC		

Suggested Land Pattern

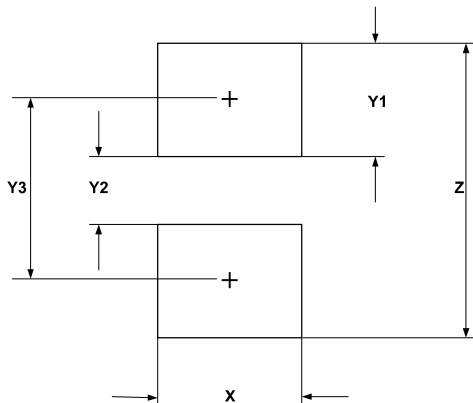

SYM	DIMENSIONS	
	MILLIMETERS	INCHES
X	0.30	0.012
Y1	0.25	0.010
Y2	0.15	0.006
Y3	0.40	0.016
Z	0.65	0.026