

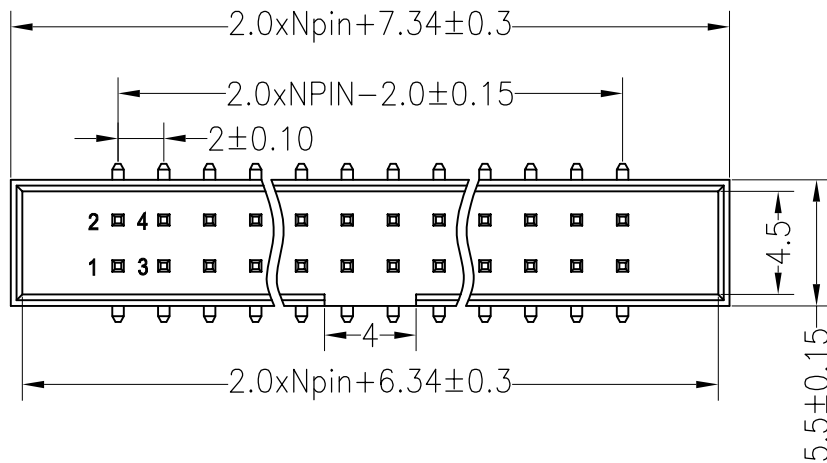

SPECIFICATIONS

Rated Current:1.5AMP
 Contact Resistance:20mΩ Max
 Withstand Voltage:400V AC/DC
 Insulation Resistance:800MΩ Min
 Operation Temperature:-40°C to +105°C

Contact Material:Brass
 Contact Plating:Au or Sn Over Ni
 Insulator Material:Polyester(UL94V-0)
 Standard: PA6T
 Max.Processing Temp: 230°C for 30-60 seconds
 (260°C for 10 seconds)



Recommended P.C.B Layout(Top Side)
 (PCB BOARD TOLERANCE±0.05)

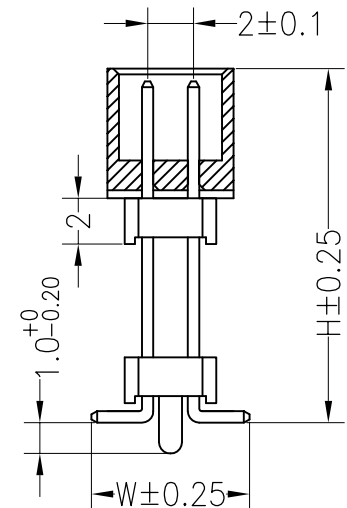
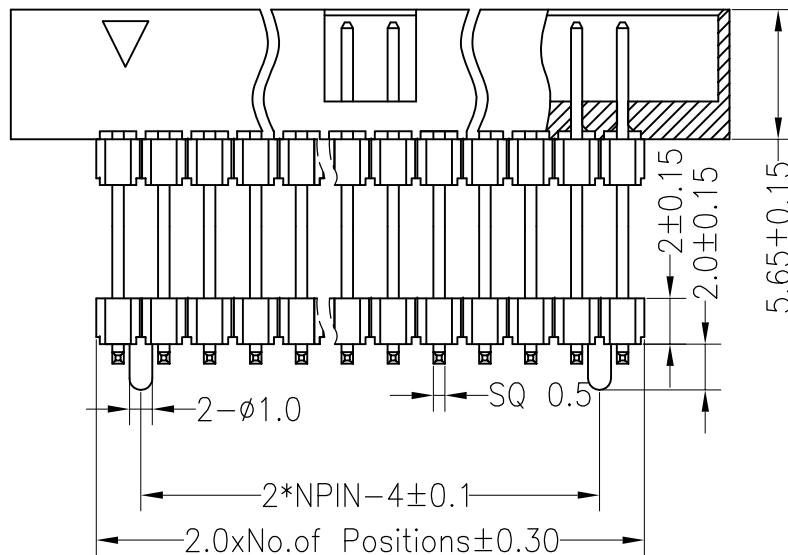
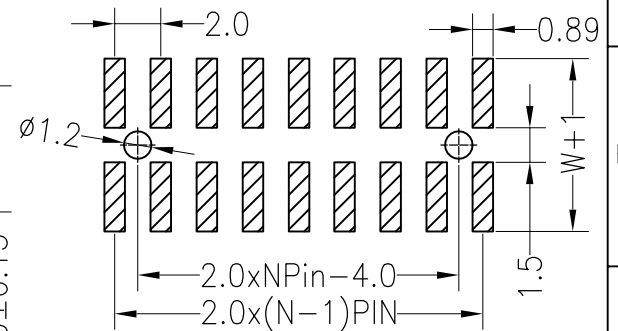

Dimension antitheses list				
ITEM	D	W	PB	L
Alternate	0.50	6.50	16.90	18.00

				OPERATION		DRAW		SCALE	FIT	深圳市连盛精密连接器有限公司		
				X.X	±0.30			UNIT	mm			
				X.XX	±0.20	CHECK		SIZE	A4	PART NO.		BH-00045
				X.XXX	±0.10			SHEET	1/1	TITLE:		2.0Box 36P 3H=5.65+2X2.00
				Angle	±3°	APPROVE		PROJ.	◆	SMT=6.5 总高16.9		
REV	DATE	MODIFICATION DESCRIPTION	CHANGE	DIM	TOL							
1	2012.03.28	NEW DRAWING										