

MLX90373 Triaxis[®] Position Processor

Datasheet

Features and Benefits

- **Triaxis[®]** Hall Technology.
- On-Chip Signal Processing for Robust Absolute Position Sensing.
- **ASIL[®] READY** BY MELEXIS ISO26262 ASIL-C Safety Element out of Context (SEooC).
- Programmable Measurement Range.
- Programmable Linear Transfer Characteristic (Multi-points 4 or 8 points or Piece-Wise-Linear 17 or 32 points).
- 2-wire PSi5 protocol (v1.3 and v2.1).
- 48 bit ID Number option.
- Dual Die (Full Redundant) - TSSOP-16 Package (RoHS).
- PCB-less DMP-4 Package (RoHS).
- Robustness against Stray-Field.

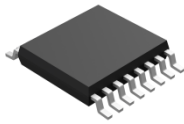

TSSOP-16

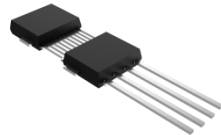

DMP-4

Application Examples

- Absolute Rotary Position Sensor.
- Absolute Linear Position Sensor.
- Pedal Position Sensor.
- Throttle Position Sensor.
- Ride Height Position Sensor.
- Steering Wheel Position Sensor.
- Fuel Level Sensor.
- Non-Contacting Potentiometer.

Description

The MLX90373 is a monolithic sensor sensitive to the three components of the flux density applied to the IC (i.e. B_x , B_y and B_z). This allows the MLX90373 with the correct magnetic circuit to decode the absolute position of any magnet moving in its vicinity (e.g. rotary position from 0 to 360 Degrees or linear displacement, see Figure 2).

The MLX90373 provides a 2-wires PSi5 (Peripheral Sensor Interface 5) output protocol over the supply line. The protocol is compatible with v1.3 and v2.1 PSi5 specifications.

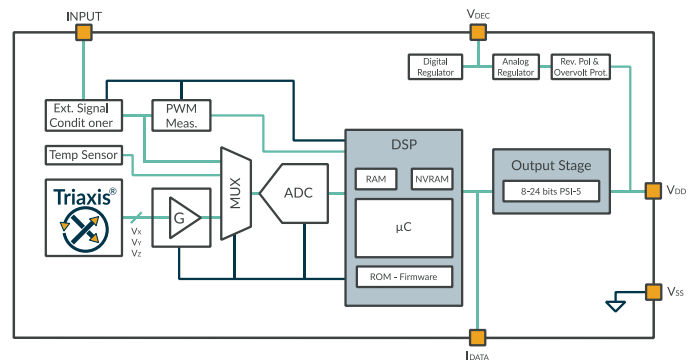

Ordering Information

Product	Temp	Package	Option Code	Packing Form	Definition
MLX90373	K	VS	ABA-100	RE/RX	Angular Position Stray-Field Immune
MLX90373	K	VS	ABA-103	RE/RX	Angular Position Stray-Field Immune
MLX90373	K	VS	ABA-108	RE/RX	Angular Position Stray-Field Immune
MLX90373	K	VS	ABA-300	RE/RX	Linear / Angular Position
MLX90373	K	VS	ABA-303	RE/RX	Linear / Angular Position
MLX90373	K	VS	ABA-308	RE/RX	Linear / Angular Position
MLX90373	K	GO	ABA-300	RE	Linear / Angular Position

Legend:

Temperature Code:	K : from -40°C to 125°C
Package Code:	GO : TSSOP-16 package (fully redundant dual die, see 18.1) VS : DMP-4 package (dual mold PCB-less, see 18.2)
Option Code:	ABA : die Version xxx-123 : 1 : Application – Magnetic configuration <ul style="list-style-type: none"> ▪ 1: Angular Rotary Stray-Field Immune ▪ 3: Legacy / Angular Rotary / Linear position 2 : SW Configuration <ul style="list-style-type: none"> ▪ 0 : Default Configuration 3 : Trim-and-Form for DMP-4 package <ul style="list-style-type: none"> ▪ 0: Standard straight leads. See 18.2.1.1 ▪ 3: Trim-and-Form STD2 2.54. See 18.2.1.2 ▪ 8: Trim-and-Form STD4 2.54. See 18.2.1.3
Packing Form:	RE : Tape & Reel RX : Tape & Reel, similar to RE with parts face-down (DMP-4 package only)
Ordering Example:	“MLX90373KVS-ABA-100-RE” For an Angular Rotary Stray-Field Immune application in DMP-4 package, delivered in Reel, face-up.

Table 1: Ordering information legend

Contents

Features and Benefits	1
Application Examples	1
Description.....	1
Ordering Information.....	2
1. Functional Diagram and Application Modes.....	5
2. Glossary of Terms.....	6
3. Pin Definitions and Descriptions.....	7
3.1. Pin Definition for TSSOP-16 Package.....	7
3.2. Pin Definition for DMP-4 Package	7
4. Absolute Maximum Ratings.....	8
5. Isolation Specification	8
6. General Electrical Specifications.....	8
7. Timing Specification	10
7.1. Definitions.....	10
7.2. General Timing	11
7.3. PSi5 Timing	11
8. Magnetic Field Specifications	12
8.1. Rotary Stray-Field Immune (-10x code)	12
8.2. Standard/Legacy Mode (-30x code)	13
9. Accuracy Specifications	14
9.1. Angular accuracy	14
9.2. Angular Velocity Accuracy	17
9.3. Temperature Accuracy.....	17
10. Memory Specification	18
11. PSi5 Communication Interface	18
11.1. PSi5 Communication Supported Standards.....	18
11.2. Data Current Modulation	18
11.3. Communication Mode	20
11.4. Cycle Time.....	21
11.5. Data Frame in Run-Time	22
11.6. Sensor Start-Up	24
11.7. Sensor Initialization	24
11.8. Error Reporting Mode.....	26

12. End-User Programmable Items	27
12.1. End-User Identification Items.....	31
13. Description of End-User Programmable Items	31
13.1. Output Transfer Characteristic.....	31
13.2. Sensor Front-End.....	37
13.3. Filter	38
13.4. Programmable Diagnostics Settings.....	40
14. Functional Safety	41
14.1. Safety Manual.....	41
14.2. Safety Mechanisms	41
15. Recommended Application Diagrams	44
15.1. Wiring in TSSOP-16 Package.....	44
15.2. Wiring in DMP-4 Package	45
16. Standard Information Regarding Manufacturability Of Melexis Products With Different Soldering Processes	46
17. ESD Precautions	46
18. Package Information	47
18.1. TSSOP-16 Package.....	47
18.2. DMP-4 Package	49
19. Contact	55
20. Disclaimer	55

1. Functional Diagram and Application Modes

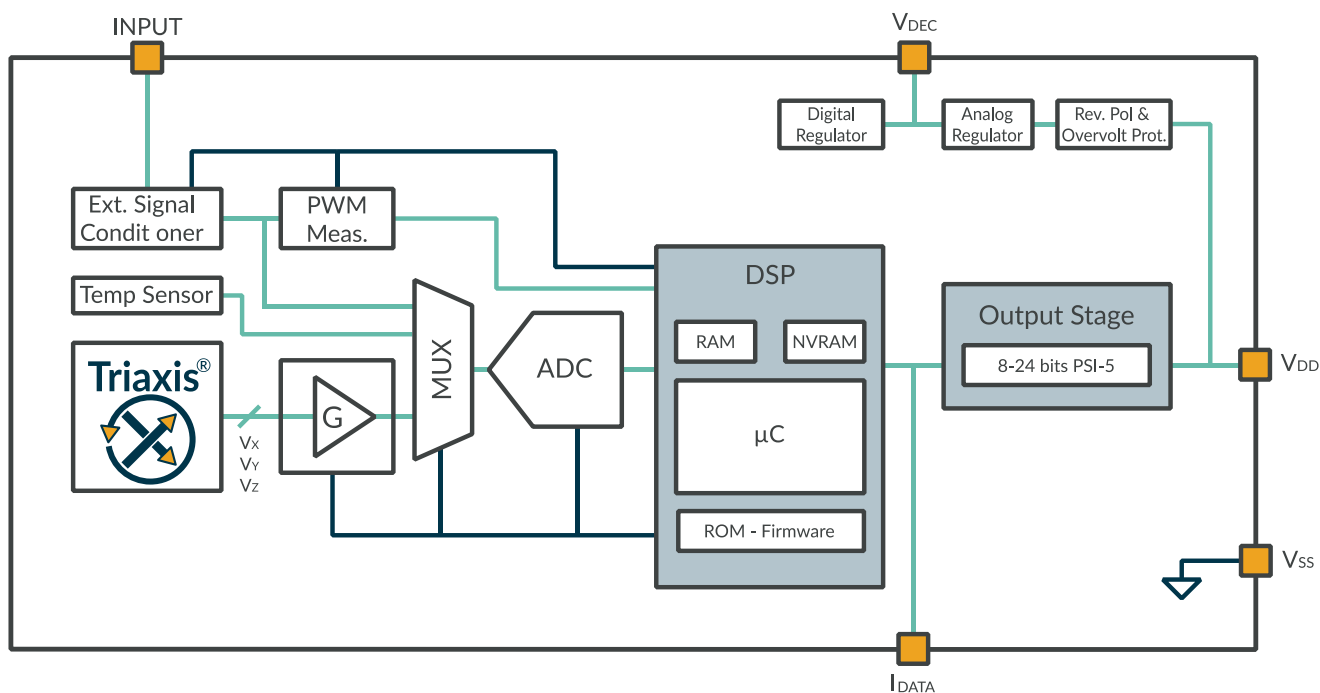

Figure 1: MLX90373 Block Diagram

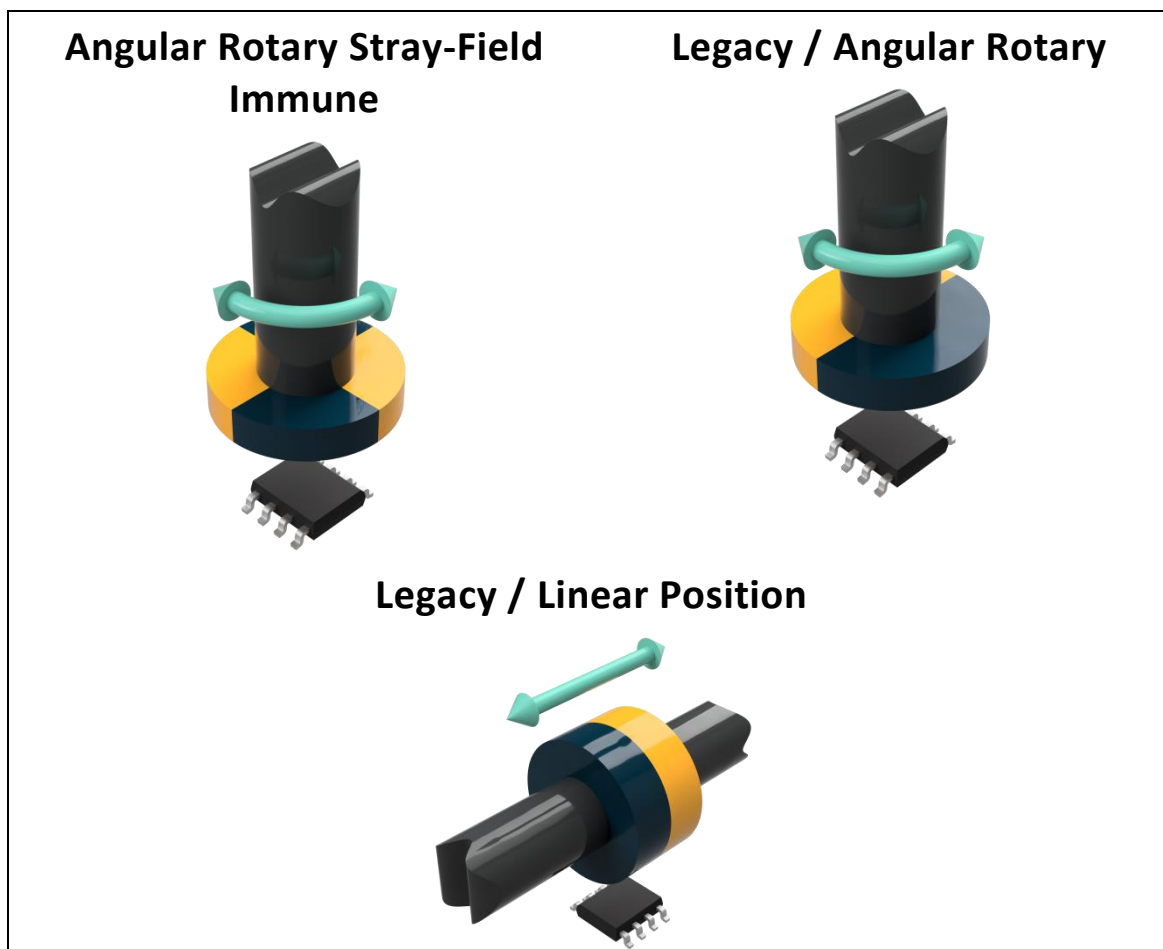

Figure 2: Application Modes

2. Glossary of Terms

Name	Description
ADC	Analog-to-Digital Converter
AWD	Absolute Watchdog
CPU	Central Processing Unit
CRC	Cyclic Redundancy Check
DMP	Dual Mould Package
DP	Discontinuity Point
DSP	Digital Signal Processing
ECC	Error Correcting Code
ECU	Electronic Control Unit
EMA	Exponential Moving Average
EMC	Electro-Magnetic Compatibility
EoL	End of Line
FIR	Finite Impulse Response
Gauss (G)	Alternative unit for the magnetic flux density (10G = 1mT)
HW	Hardware
IMC	Integrated Magnetic Concentrator
IWD	Intelligent Watchdog
LSB/MSB	Least Significant Bit / Most Significant Bit
NC	Not Connected
NVRAM	Non Volatile RAM
PSF	Product Specific Functions
PSI5	Peripheral Sensor Interface 5
PTC	Programming Through Connector
PWL	Piecewise Linear
RAM	Random Access Memory
ROM	Read-Only Memory
SEoC	Safety Element out of Context
TC	Temperature Coefficient (in ppm/°C)
Tesla (T)	SI derived unit for the magnetic flux density (Vs/m ²)

Table 2: Glossary of Terms

3. Pin Definitions and Descriptions

3.1. Pin Definition for TSSOP-16 Package

Pin #	Name	Description
1	V _{DEC1}	Decoupling pin die 1
2	V _{SS1}	Ground die 1
3	V _{DD1}	Supply die 1
4	IN ₁	External sensor input die 1
5	TEST ₂	Test pin die 2
6	IDATA ₂	Current sensing die 2
7	N.C.	Not connected
8	N.C.	Not connected
9	V _{DEC2}	Decoupling pin die 2
10	V _{SS2}	Ground die 2
11	V _{DD2}	Supply die 2
12	IN ₂	External sensor input die 2
13	TEST ₁	Test pin die 1
14	N.C.	Not connected
15	IDATA ₁	Current sensing die 1
16	N.C.	Not connected

Table 3: TSSOP-16 Pin definition and description

Pins Input and Test are internally grounded in application. For optimal EMC behavior always connect the unused pins to the ground of the PCB. Pins IDATA must be non-connected.

3.2. Pin Definition for DMP-4 Package

Pin #	Name	Description
1	V _{SS}	Ground
2	V _{DD}	Supply/PSI5-OUT
3	N.C.	Not connected
4	V _{SS}	Ground

Table 4: DMP-4 Pin definition and description

4. Absolute Maximum Ratings

Parameter	Symbol	Min.	Max.	Unit	Condition
Supply Voltage	V_{DD}		27	V	< 24h ; $T_J < 175^\circ\text{C}$
	V_{DD}		37	V	< 60s ; $T_{AMB} \leq 35^\circ\text{C}$
Reverse Voltage Protection	V_{DD-REV}	-14		V	< 24h ; $T_J < 175^\circ\text{C}$
	V_{DD-REV}	-20		V	< 1h
Internal Voltage	V_{DEC}		3.6	V	
Internal Voltage	$V_{DEC-rev}$	-0.3		V	
Positive Input pin Voltage	V_{Input}		6	V	
Reverse Input pin Voltage	$V_{Input-rev}$	-3		V	
Operating Temperature	T_{AMB}	-40	125	$^\circ\text{C}$	
Junction Temperature	T_J		175	$^\circ\text{C}$	See 18.2.5 and 18.1.5 for packages thermal dissipation values
Storage Temperature	T_{ST}	-55	170	$^\circ\text{C}$	Refer to the qualification profile
Sensed magnetic field	B_{MAX}	-1	1	T	

Table 5: Absolute maximum ratings

Exceeding the absolute maximum ratings may cause permanent damage. Exposure to absolute maximum-rated conditions for extended periods may affect device reliability.

5. Isolation Specification

Only valid for the package code GO, i.e. TSSOP-16 package (dual die).

Parameter	Symbol	Min.	Typ.	Max.	Unit	Condition
Isolation Resistance	R_{isol}	4	-	-	$M\Omega$	Between dice, measured between V_{SS1} and V_{SS2} with +/-20V bias

Table 6: Isolation Specification

6. General Electrical Specifications

General electrical specifications are valid for temperature range [-40; 125] $^\circ\text{C}$ and the supply voltage range inside their defined operating range unless otherwise noted.

Electrical Parameter	Symbol	Min	Typ	Max	Unit	Condition
Operating Supply Voltage during PSi5 communication	V_{DD}	6	12	18 ⁽¹⁾	V	DMP-4 package
	V_{DD}	4.1	5	6 ⁽¹⁾	V	TSSOP-16 and DMP-4 package
Quiescent Supply current ⁽²⁾	I_{DDQ}	10	11.5	13.5	mA	Rotary Stray-Field application (option code -10x).
Quiescent Supply current ⁽²⁾	I_{DDQ}	9	10.5	12.5	mA	Legacy application (option code -30x).
Start-up Level	$V_{DDstart}$	3.6			V	Minimal supply start-up voltage
Undervoltage detection	V_{DDUVH}	3.8	4.0	4.1	V	High threshold
Undervoltage detection	V_{DDUVL}	3.70	3.90	4.00	V	Low threshold
Start-up Hysteresis	$V_{DDstartHyst}$	0.05	0.10	0.15	V	
PTC Entry Level (rising)	V_{PROV1}	22	24	26	V	
PTC Entry Level Hysteresis	$V_{PROV1Hyst}$	0.8	1.4	2.0	V	
Current settling error at startup	$I_{ERRSTART}$	-2		2	mA	Current consumption settling error 5ms after power-up
Microcut rejection	T_{ucut}		10		μs	PSi5 std.
Regulated Voltage	V_{DEC}	3.2	3.3	3.4	V	Internal analog voltage
Regulated Voltage Overvoltage detection	V_{DECOVH}	3.65	3.75	3.85	V	High threshold
Regulated Voltage Undervoltage detection	V_{DECUVL}	2.70	2.85	2.92	V	Low threshold
Regulated voltage UV / OV detection hysteresis	$V_{DECOVHyst}$	100	150	200	mV	
	$V_{DECUVHyst}$					
Digital supply	V_{DDD}	1.80	1.85	1.95	V	
Digital supply Overvoltage detection	V_{DDDOVH}	2.00	2.10	2.20	V	
Digital Supply Undervoltage detection	V_{DDDUVL}	1.585	1.680	1.735	V	Power-on Reset low threshold
Digital Supply OV / UV detection Hysteresis	$V_{PORHyst}$	30	100	200	mV	

Table 7: General electrical specifications

¹ The maximum PSi5 operating voltage, excluding Synchronization pulse, is limited by the die temperature and the thermal dissipation performance of the considered package.

² For the dual die version, the supply current is multiplied by 2.

7. Timing Specification

Timing conditions, including the variations of supply, temperature and aging, unless specified.

7.1. Definitions

7.1.1. Latency

Latency is the average delay between the movement of the detected object (magnet) and the response of the sensor output. This value is representative of the time constant of the system for regulation calculations.

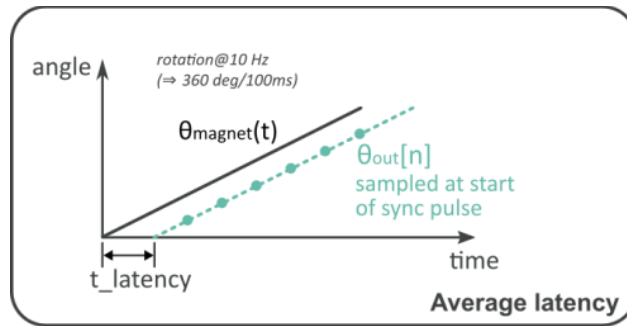

Figure 3: Definition of latency

7.1.2. Step Response

Step response is defined as the delay between the movement of the detected object (magnet) and the 100% settling time of the sensor output with full angle accuracy with regards to filtering. Worst case is happening when the movement of the magnet occurs just after a measurement sequence has begun. Step response therefore consists of the sum of:

- $\delta_{mag,measSeq}$: the delay between magnetic change and start of next measurement sequence.
- $T_{measSeq}$: the measurement sequence length.
- $\delta_{measSeq,frameStart}$: the delay between end of measurement sequence and start of next frame.
- T_{frame} : the frame length.

Worst case happens when $\delta_{mag,measSeq} = T_{measSeq}$, which gives: $T_{wcStep} = 2T_{measSeq,frameStart} + T_{frame}$

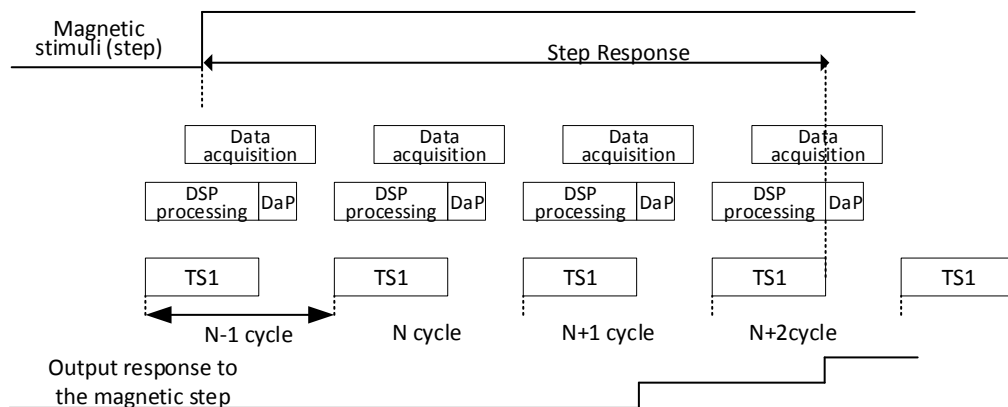

Figure 4: Step response and latency

7.2. General Timing

General electrical specifications are valid for temperature range [-40;125] °C and supply voltage range [4.1;5.5] V unless otherwise noted.

Parameter	Symbol	Min.	Typ.	Max.	Unit	Condition
Main Clock Frequency	F _{CK}	22.8	24	25.2	MHz	Including thermal and lifetime drift
		-5		5	% F _{CK}	Relative tolerances, including thermal and lifetime drift
Main Clock Frequency Thermal Drift	ΔF _{CK,0}	-2		2	% F _{CK}	Relative to clock frequency at 35°C. No ageing effects.
1MHz Clock Frequency	F _{1M}		1		MHz	
Intelligent Watchdog Timeout	T _{IWD}	19	20	21	ms	F _{CK} = 24MHz
Absolute Watchdog Timeout	T _{AWD}	19	20	21	ms	F _{1M} = 1MHz
Analog Diagnostics	DCT _{ANA}			15.5 9.3	ms	T _{cycle} = 500μs T _{cycle} = 300μs
Digital Diagnostics	DCT _{DIG}			20	ms	
Current settling Time at start-up ⁽³⁾	TSET		4	5	ms	Stabilization of the quiescent current after start-up power on
Start-up time	TSU	5			ms	when no diagnostic is enabled
				20.5	ms	when all diagnostics are enabled

Table 8: General Timing Specification

7.3. PSI5 Timing

Parameter	Symbol	Min.	Typ	Max	Unit	Condition
Cycle time	T _{cycle}		300 500		μs	
Bit time	T _{bit}	5		8.4	μs	
Sync Pulse Hold Time	TSHOLD	9			μs	Synchronous mode only
Data acquisition		150		350	μs	5 acquisitions at 4 MHz 9 acquisitions at 3 MHz
DSP calculation + Data preparation		250	350		μs	2 phase spinning + DSP trimming down Default configuration
Latency Time	T _{latency}		850		μs	Default configuration, no filtering
Step Response Time ⁽⁴⁾	T _{wcStep}		1480		μs	Rotary mode, default configuration, no filtering
			2125			Velocity mode, default configuration, no filtering

Table 9: PSI5 Timing Specification

³ Due to duration of initialization phases in PSI5 protocol no PSI5 data frame will be transmitted before initialization phase II.

⁴ Main clock variations not included.

8. Magnetic Field Specifications

Magnetic field specifications are valid for temperature range [-40; 125] °C unless otherwise noted.

8.1. Rotary Stray-Field Immune (-10x code)

Parameter	Symbol	Min	Typ	Max	Unit	Condition
Number of magnetic poles	N_p	4 ⁽⁵⁾	-	-		
Magnetic Flux Density in X-Y plane	B_x, B_y ⁽⁶⁾			25 ⁽⁷⁾	mT	$\sqrt{B_x^2 + B_y^2}$ (this is not the useful signal)
Magnetic Flux Density in Z	B_z			100	mT	(this is not the useful signal)
Magnetic in-plane gradient of in-plane field component	$\frac{\Delta B_{XY}}{\Delta XY}$	4.1	10		$\frac{mT}{mm}$	$\frac{1}{2} \sqrt{\left(\frac{dB_x}{dX} - \frac{dB_y}{dY}\right)^2 + \left(\frac{dB_x}{dY} + \frac{dB_y}{dX}\right)^2}$ this is the useful signal (see Figure 5)
Magnet Temperature Coefficient	TC_m	-2400		0	$\frac{ppm}{^\circ C}$	
Field Strength Resolution ⁽⁸⁾	$\frac{\Delta B_{XY}}{\Delta XY}$	0.075	0.100	0.125	$\frac{mT}{mm \text{ LSB}}$	Magnetic field gradient norm (12bits data)
Field too Low Threshold ⁽⁹⁾	B_{TH_LOW}	0.8	1.2	⁽¹⁰⁾	$\frac{mT}{mm}$	Typ. value recommended
Field too High Threshold ⁽⁹⁾	B_{TH_HIGH}	70	100 ⁽¹¹⁾	102 ⁽¹¹⁾	$\frac{mT}{mm}$	

Table 10 Magnetic specification for rotary Stray-Field immune application

Nominal performances apply when the useful signal $\Delta B_{XY}/\Delta XY$ is above the typical specified limit. Under this value, limited performances apply. See 9.1 for accuracy specifications.

⁵ Due to 4 poles magnet usage, maximum angle measurement range is limited to 180°

⁶ The condition must be fulfilled for all combinations of B_x and B_y .

⁷ Above this limit, the IMC® starts to saturate, yielding to an increase of the linearity error.

⁸ Only valid with default MAGNET_SREL_T[1..7] configuration

⁹ See section 11 for the value set by default.

¹⁰ Higher values of Field too Low threshold are not recommended by Melexis and shall only be set in accordance with the magnetic design and taking a sufficient safety margin to prevent false positive.

¹¹ Due to the saturation effect of the IMC, the FieldTooHigh monitor detects only defects in the sensor

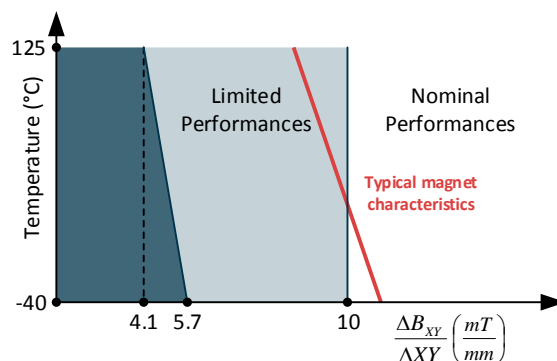

Figure 5: Minimum useful signal definition for rotary Stray-Field immune application

8.2. Standard/Legacy Mode (-30x code)

Parameter	Symbol	Min.	Typ.	Max.	Unit	Condition
Number of magnetic poles	N_p	-	2	-		
Magnetic Flux Density in X-Y plane	$B_x, B_y^{(6)}$			70	mT	$\sqrt{B_x^2 + B_y^2}$
Magnetic Flux Density in Z	B_z			100	mT	in absolute value
Useful Magnetic Flux Density Norm	B_{Norm}	11 ⁽¹²⁾	20		mT	$\sqrt{B_x^2 + B_y^2}$ (x-y mode) $\sqrt{B_x^2 + \left(\frac{1}{G_{IMC}} B_z\right)^2}$ (x-z mode) $\sqrt{B_y^2 + \left(\frac{1}{G_{IMC}} B_z\right)^2}$ (y-z mode) See section 13.2.1 for sensing mode description.
IMC gain	G_{IMC}		1.19			⁽¹³⁾
Magnet Temperature Coefficient	TC_m	-2400		0	$\frac{ppm}{^\circ C}$	
Field Strength Resolution ⁽⁸⁾	B_{Norm}	0.075	0.100	0.125	$\frac{mT}{LSB}$	Magnetic field gradient norm expressed in 12bits words
Field too Low Threshold ⁽⁹⁾	B_{TH_LOW}	0.4	4.0	⁽¹⁰⁾	mT	Typ. Value recommended
Field too High Threshold ⁽⁹⁾	B_{TH_HIGH}	70	100 ⁽¹¹⁾	100 ⁽¹¹⁾	mT	

Table 11: Magnetic specification for standard application

Nominal performances apply when the useful signal B_{Norm} is above the typical specified limit. Under this value, limited performances apply. See 9.1 for accuracy specifications.

¹² Below 11 mT the performances are degraded due to a reduction of the signal-to-noise ratio, signal-to-offset ratio

¹³ IMC has better performance for concentrating in-plane (x-y) field components, resulting in a better overall magnetic sensitivity. A correction factor, called IMC gain has to be applied to the z field component to account for this difference.

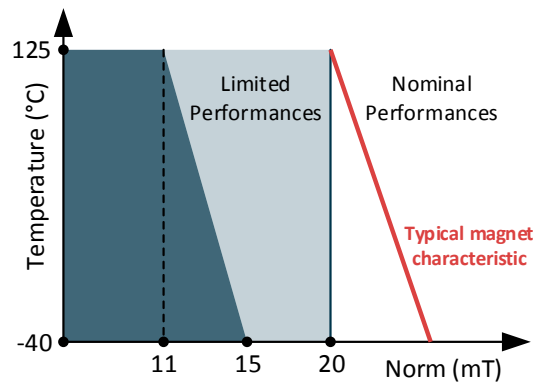

Figure 6: Minimum useful signal definition for Standard/Legacy application

9. Accuracy Specifications

Accuracy specifications are valid for temperature range [-40; 125] °C and supply voltage range specified in section 6 unless otherwise noted.

9.1. Angular accuracy

9.1.1. Definitions

9.1.1.1. Intrinsic Linearity Error

Figure 7 depicts the intrinsic linearity error in new parts. The Intrinsic Linearity Error refers to the IC itself (offset, sensitivity mismatch, orthogonality) taking into account an ideal magnetic field. Once associated to a practical magnetic construction and the associated mechanical and magnetic tolerances, the output linearity error increases. However, it can be improved with the multi-point end-user calibration (see 13.1). As a consequence, this error is not critical in application because it is calibrated away.

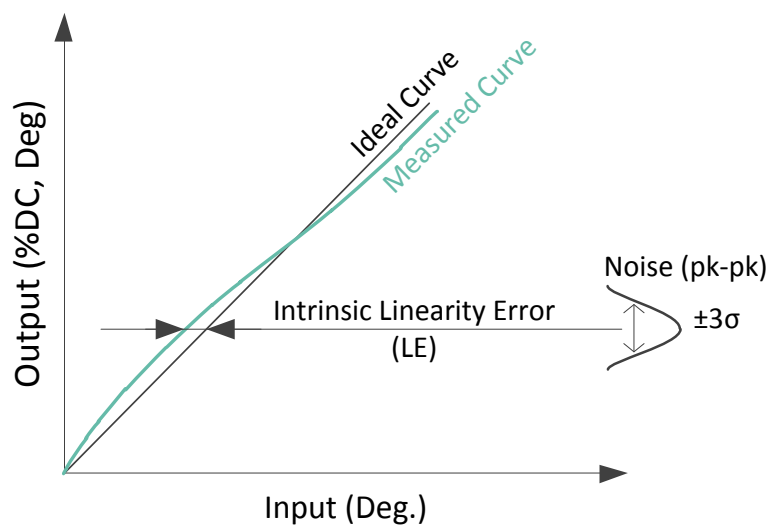

Figure 7: Sensor accuracy definition

9.1.1.2. Total Angle Drift

After calibration, the output angle of the sensor might still change due to temperature change, aging, etc.. This is defined as the total drift $\partial\theta_{TT}$:

$$\partial\theta_{TT} = \max\{\theta(\theta_{IN}, T, t) - \theta(\theta_{IN}, T_{RT}, t_0)\}$$

where θ_{IN} is the input angle, T is the temperature, T_{RT} is the room temperature, and t is the elapsed lifetime after calibration. t_0 represents the status at the start of the operating life. Note the total drift $\partial\theta_{TT}$ is always defined with respect to angle at room temperature. In this datasheet, T_{RT} is typically defined at 35°C, unless stated otherwise. The total drift is valid for all angles along the full mechanical stroke.

9.1.1. Performances

Valid before EoL calibration and for all applications under nominal performances conditions described in sections 8.1 & 6.

Mode	Parameter	Symbol	Nominal performances			Limited performances			Unit	Condition	
			Min	Typ	Max	Min	Typ	Max			
Rotary Stray-Field Immune (-10x code)	XY - Intrinsic Linearity Error	L_{E_XY}	-1		1	-1		1	Deg.		
	Noise ⁽¹⁴⁾				0.4			0.7	Deg.	Filter = 0 ⁽¹⁵⁾	
					0.2			0.5	Deg.	Filter = 1	
								0.35	Deg.	Filter = 2	
	XY - Total Drift ⁽¹⁶⁾	$\partial\theta_{TTXY}$	-0.85		0.85	-0.85		0.85	Deg.	Relative to 35°C	
	Hysteresis			0.1			0.1	Deg.			
	Output Stray Field Immunity	$\partial\theta_{FF}$			0.6				Deg.	with 10mT/mm useful gradient field and 4kA/m stray-field ⁽¹⁷⁾	
Standard/Legacy (-30x code)	XY - Intrinsic Linearity Error	L_{E_XY}	-1		1	-1		1	Deg.		
	XZ - Intrinsic Linearity Error	L_{E_XZ}	-2.5	±1.25	2.5	-2.5	±1.25	2.5			
	YZ - Intrinsic Linearity Error	L_{E_YZ}	-2.5	±1.25	2.5	-2.5	±1.25	2.5			
	Noise ⁽¹⁴⁾				0.05	0.1				Deg.	Filter = 0; 40mT
					0.1	0.2				Deg.	Filter = 0; 20mT
								0.2	0.4	Deg.	Filter = 0
							0.14	0.28	Deg.	Filter = 1	
					0.05	0.1		0.1	0.2	Deg.	Filter = 2
XY - Total Drift	$\partial\theta_{TTXY}$	-0.45		0.45	-0.6		0.6	Deg.	Relative to 35°C		
XZ - Total Drift	$\partial\theta_{TTXZ}$	-0.6		0.6	-0.8		0.8				
YZ - Total Drift	$\partial\theta_{TTYZ}$	-0.6		0.6	-0.8		0.8				
	Hysteresis			0.05	0.1		0.1	0.2	Deg.	10mT 20mT	

¹⁴ ±3σ

¹⁵ See section 13.3 for details concerning Filter parameter

¹⁶ Verification done on aged devices after HTOL in uniform field gradient. The limit represents the peak to peak value of the measured distribution of the largest angle drift, calculated as 6σ of the output angle ϑ_{out} . An additional application-specific error arises from the non-ideal magnet and mechanical tolerance drift.

¹⁷ Tested in accordance with ISO 11452-8:2015 at 30°C, with stray-field strength of 4kA/m from any direction. This error scales linearly with both the useful field and the disturbing field.

9.2. Angular Velocity Accuracy

The MLX90373 device can calculate the velocity based on the angle measurement. The velocity algorithm must be enabled (VELOCITY_ENABLE) (disabling is advised for "turbo" modes with no velocity information, where computation speed is critical).

The velocity algorithm is selectable (VELOCITY_ALGORITHM, 0: simple, 1: tracking loop).

Parameter	Symbol	Min	Typ	Max	Unit	Condition
Angular velocity range	ASFS	-1000	-	+1000	Deg./s	
Angular velocity error			26	145	Deg./s	Only error calculation is considered. Max is considering abrupt velocity change 0 to 1000 Deg./s
Angular velocity noise ⁽¹⁴⁾ For VELOCITY_FILTER_FIR=0			31 23	43 41	Deg./s	VELOCITY_ALGORITHM =0 VELOCITY_ALGORITHM =1

9.3. Temperature Accuracy

One can get the physical temperature of the die using following formula:

$$T_{PHY}[^{\circ}C] = \frac{T_{LIN}}{8} - 73.15$$

DIAG_TEMP_THR_LOW/HIGH are encoded on 8-bit unsigned values with the following relationship towards T_{Lin}

$$DIAG_TEMP_THR_(LOW/HIGH) = \frac{T_{LIN}}{16}$$

Following table summarizes the characteristics of the linearized temperature sensor and the encoding of the temperature monitor thresholds.

Parameter	Symbol	Min	Typ	Max	Unit	Condition
TLIN resolution	Res _{TLIN}	-	0.125	-	°C/LSB	
TLIN refresh rate	F _{S,TLIN}	-	200	-	Hz	
TLIN linearity error	T _{LinErr}	-8	-	8	°C	from -40 to 125°C
DIAG_TEMP_THR_LOW		-	8	-	LSB	Recommended value, corresponds to -57°C
DIAG_TEMP_THR_HIGH		-	136	-	LSB	Recommended value, corresponds to 199°C
Temperature threshold resolution	ResTthr		2		°C/LSB	

Table 12: Linearized Temperature Sensor characteristics (die temperature)

10. Memory Specification

Parameter	Symbol	Min.	Typ.	Max.	Unit	Condition
ROM			32		kB	
RAM			1024		B	
NVRAM			256		B	

Table 13: Memory specification

11. PSi5 Communication Interface

11.1. PSi5 Communication Supported Standards

The MLX90373 uses PSi5 communication protocol. The information is transmitted by modulating the current of the supply pin VDD according to PSi5 protocol specification. The sensor interface, electrical parameters and data transmission fully complies with v2.1 of the PSi5 protocol specifications. The backward compatibility to the operation modes described in v1.3 of PSi5 standard is also part of the MLX90373 implementation. The configuration of the sensor interface follows the "Chassis and Safety PSi5 Substandard".

The denomination of the PSi5 protocol is defined as follows:

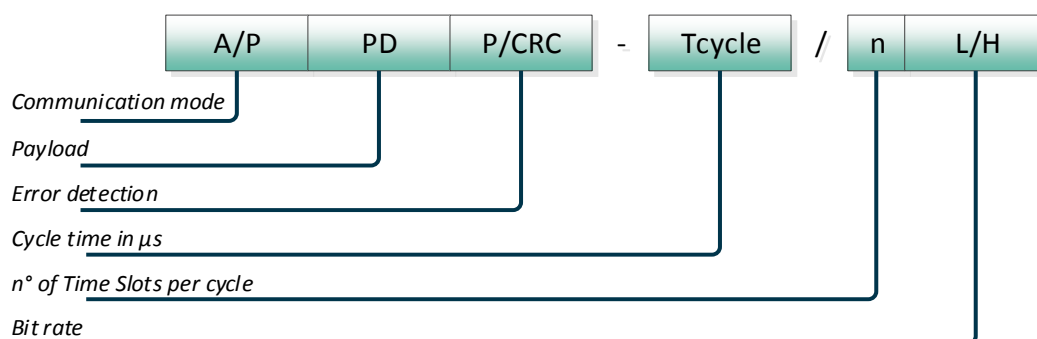

Figure 8: Denomination of PSi5 operation modes

11.2. Data Current Modulation

11.2.1. PSi5 Current Modulation Method

The Data Frame is transmitted through a modulation of the current consumption. The Figure 9 shows the current modulation and bit encoding (Manchester encoding). A low level ($I_{S_{low}}$) represents the quiescent current consumption of the sensor. A high level ($I_{S_{high}}$) is generated by an increased Sink current of the sensor ($I_{S_{low}} + \Delta I_S$). The sink current (ΔI_S) and the duration of the bit (T_{BIT}) are selectable (see Table 14).

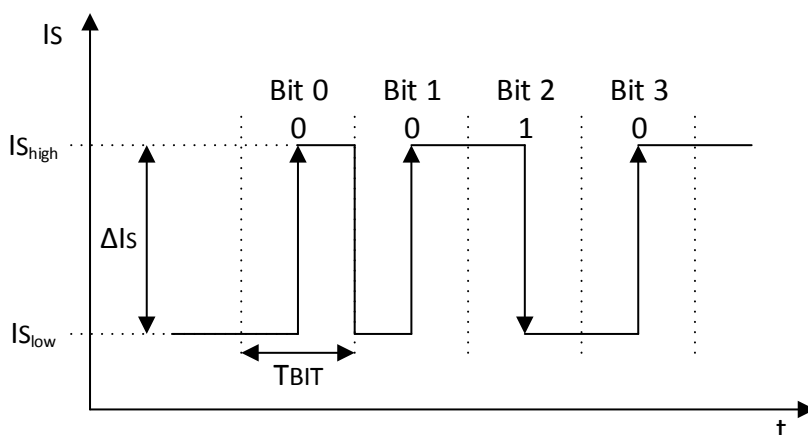

Figure 9: PSi5 current modulation

11.2.2. Current Modulation Specification

Electrical Parameter	Symbol	Min	Typ	Max	Unit	Condition
Sink current	ΔI_S	21	26	30 ⁽¹⁸⁾	mA	Common power mode (see section 12)
		10	13	15	mA	Low power mode (see section 12)
Quiescent current drift	DRIFT _{IS}	-4		4	mA	
Quiescent current thermal drift rate	DRIFT _{TRIS}			0.3	mA/s	Assuming a maximum temperature drift rate of 20K/s
IS Current modulation Falling time ⁽¹⁹⁾	T _F	0.33		1	μs	Time for IS to fall from 80% to 20% of ΔIS. See section 15.
IS Current modulation Rising time ⁽¹⁹⁾	T _R	0.33		1	μs	Time for IS to rise from 20% to 80% of ΔIS. See section 15.
Mark/Space Ratio at Sensor ⁽²¹⁾	MSR	47 ⁽²²⁾	50	53	%	(t _{fall, 80} - t _{rise, 20}) / T _{Bit} (t _{fall, 20} - t _{rise, 80}) / T _{Bit}
Bit time	T _{BIT}	7.6	8	8.4	μs	Low speed transmission (125 kbit/s)
		5	5.3	5.6	μs	High-speed transmission (189 kbit/s)
Slope rate			fast			High-speed transmission (189 kbit/s)
			slow			Low speed transmission (125 kbit/s)

Table 14: Data modulation specification table

For the power mode (PSI5_LOWCOMMON_MODE) and the speed transmission (PSI5_TRANSMITSPEED) programming, see section 12.

¹⁸ The maximum value is found at 125deg.C

¹⁹ Small rise and fall times will lead to increased radiated emission. Sensors/Bus must meet the test conditions of PSi5 standard.

²¹ Single sensor configuration shall satisfy the requirement for sending current rise/fall time such that rise from 20 to 80% of IS and t_{fall} from 80 down to 20% of IS is reached within 1μs..

²² Minimum value of duty cycle has been found at 125deg.C

11.3. Communication Mode

The sensor can be programmed to communicate in 2 possible modes: asynchronous mode and synchronous parallel bus mode (see Table 15). In asynchronous mode, the sensor transmits the Data Frames periodically without external synchronization, while in synchronous mode; the communication is synchronized by the ECU with a synchronization pulse.

Protocol Parameter	Option Id	Option	NVRAM parameters
Communication modes	A	2: Asynchronous Mode	PROTOCOL
	P	3: Synchronous Parallel Bus Mode	

Table 15: Communication mode configuration synchronous/asynchronous

11.3.1. Asynchronous Communication

In asynchronous mode, the timing and repetition rate of the data transmission are controlled by the sensor. The sensor starts transmitting the data to the ECU periodically (see section 11.4) once the power supply is on.

The Figure 10 shows the periodic transmission from one PS15 Sensor with period T_{cycle} . The supply voltage must enter the operation voltage specified in the section 6.

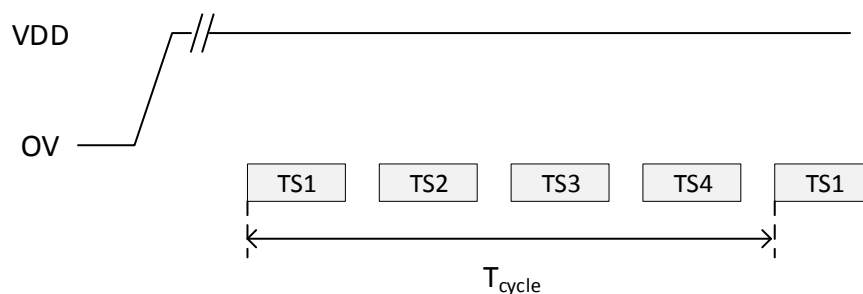

Figure 10: Asynchronous data transmission for x4 Time Slots per cycle

11.3.2. Synchronous Communication in Parallel Bus

In synchronous operation, the sensor data transmission is synchronized by the ECU using voltage modulation. Once the sync pulse received, each sensor starts the data transmission (see section 11.3.2.1).

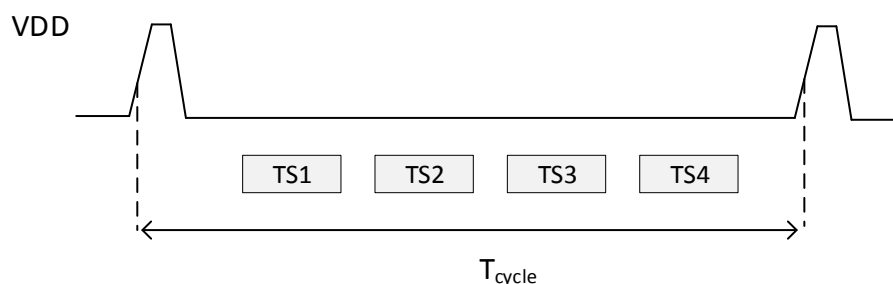

Figure 11: Synchronous Parallel bus data transmission for x4 Time Slots per cycle

11.3.2.1. Synchronization Pulse

The sync pulse generated by the ECU is detected by the sensor as soon as the variation in voltage on VDD is higher than the minimum sync pulse voltage. The sync pulse (reduced or standard, see Table 16) is selectable (PSI5_TRIGGER_STD).

Electrical Parameter	Symbol	Min	Typ	Max	Unit	Condition
Sync Pulse Voltage	VSYNC	2.5			V	For reduced sync pulse
		3.5			V	For standard sync pulse
Sensor Trigger threshold	VTRIG	1.2	1.5	1.8	V	For reduced sync pulse
		1.4	2.0	2.6	V	For standard sync pulse
Tolerance of internal trigger detection timing delay at sensor	TTOLDETECT			3	µs	See definition of parameter in PSI5 spec
Sync Pulse Hold Time	TSHOLD	9			µs	For reduced sync pulse
		36			µs	For standard sync pulse

Table 16: Synchronization pulse parameters

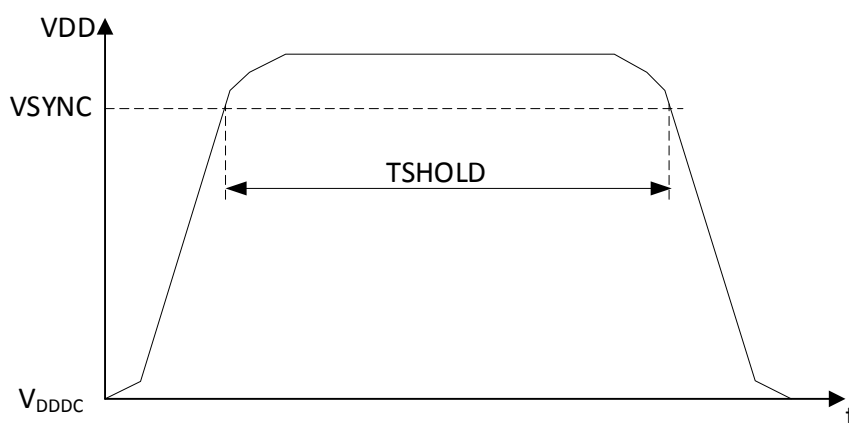

Figure 12: Sync pulse detection

VDDDC being the static value of the supply voltage before the synchronization pulse occurs.

11.4. Cycle Time

The periodicity of transmission (or Cycle Time) is programmable, see Figure 10. The maximum number of Time Slots (time allocation of a Data Frame within a Cycle) is 4. Each Time Slot must be enabled (PSI5_TSx_ENABLE) and a corresponding start time specified (PSI5_TSx_STARTTIME). The time separating two consecutive Time Slots, TGAP, must be higher than TBIT.

Protocol Parameter	Symbol	Option	NVRAM parameters
PSI5 Cycle time selection	T_{cycle}	0: 500 μs	PSI5_CYCLETIME
		1: 300 μs	

Table 17: Cycle time selection

11.5. Data Frame in Run-Time

11.5.1. Data Frame Content

The Data Frame consists in Start, Payload and Error Detection bits, see Table 18. The Payload consists in Control (optional), Status (optional) and Data bits.

Data Frame content	Bit Symbol	Description
Start bits	S0, S1	Frame start bits, always coded as "0"
Payload (PD)	Control bits	F0-2 Optional (only for High precision format). Rolling counter, incremented once per Time Slot, during run-time and error transmission, with LSB transmission first. Overflow leads to a reset, e.g. 0x7+0x1=0x0.
	Status bit	E0 Optional (only for High precision format). Error flag bit.
	Data bits	A[0:N-1] Data bits, transmitted LSB first. Recommended number of bits for data, $N \in \{8, 10, 16, 20\}$.
Error Detection bits	P	Parity bit
	C0-2	CRC

Table 18: Description of data Content in run time

11.5.2. Data Frame Format

The Error Detection, the Payload size and the Format Precision are selectable, see Table 19.

Protocol Parameter	Option Id	Option	NVRAM parameters
Error Detection	P/CRC	0: CRC mode 1: Parity Bit mode	PSI5_ERRORDETECTION
Payload (PD)	N/A	Selectable between 8 to 24 bits.	PSI5_PAYLOAD_SIZE
Data Frame Format precision	N/A	0: PSI5 low precision 1: PSI5 high precision	PSI5_FRAMEFORMAT_STD

Table 19: Parameterization of the format data

11.5.2.1. Data Frame Format Supported by the MLX90373

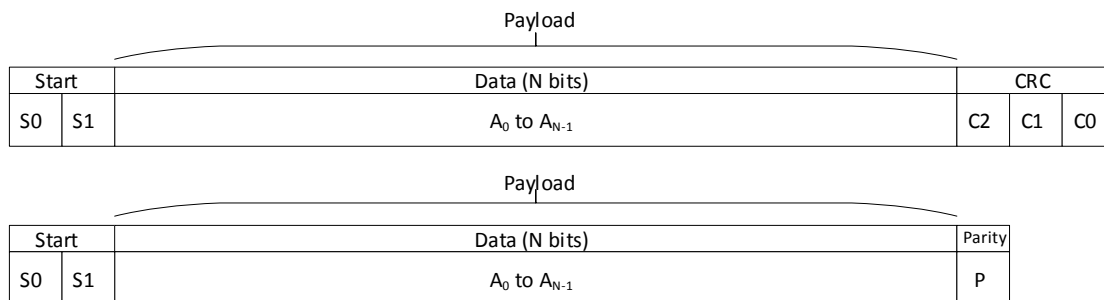

Figure 13: Low Precision Data Frame Format

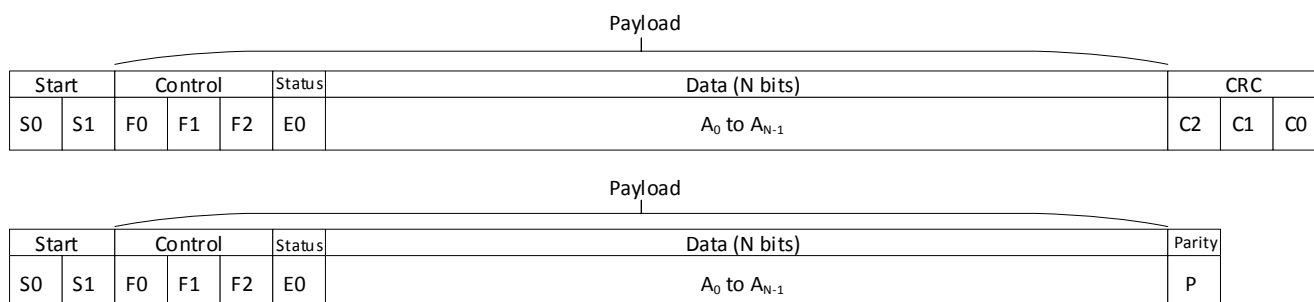

Figure 14: High Precision Data Frame Format

11.5.2.2. Example of Data Frame

Start		Data (10 bits)										Parity
S0	S1	A0	A1	A2	A3	A4	A5	A6	A7	A8	A9	P

A10P-300/1L in Low Precision Format

Start		Control			Status	Data (12 bits)											CRC			
S0	S1	F0	F1	F2	E0	A0	A1	A2	A3	A4	A5	A6	A7	A8	A9	A10	A11	C2	C1	C0

A16CRC-500/1L in High Precision Format

Figure 15: Example of Data Frame

11.5.3. Data

11.5.3.1. Data Selection

The data can be selected Time Slot by Time Slot (see Table 20).

NVRAM parameter	Number of bits	Description
PSI5_TSx_SENSORPARAM with x=1, 2, 3, 4 (Time Slot)	3	Time Slot data to be transmitted: 0x0: Angular data 0x1: Angular velocity 0x2: Temperature 0x3: Bfield 0x4: Ramprobe data
PSI5_x_NBITS with x= ANGULARDATA, ANGULARVELOCITY, TEMPERATURE, BFIELD, RAMPROBE	4	Data size: (MSB), [1 - 16] bits

Table 20: Selection of sensor data

11.5.3.2. Data Padding

Sensor Data padding is performed:

- For High precision Frame Format, when $PD > PSI5_x_NBITS + 4$
- For Low precision Frame Format, when $PD > PSI5_x_NBITS$

Where $x=ANGULARDATA, ANGULARVELOCITY, TEMPERATURE, BFIELD, RAMPROBE$.

When the padding applies, extra MSBs of $A[0:N-1]$ are transmitted from bit number $PSI5_x_NBITS$ to bit number $N-1$ and set to 0.

11.6. Sensor Start-Up

Normal or full safe start-up after power-on reset is selectable ($COLD_SAFE_STARTUP_EN$).

11.7. Sensor Initialization

After startup, three initialization phases are present before entering run-time operation mode. The initialization phases can be skipped or enabled and configured after reset or error recovery. The parameters associated are $PSI5_COLD_INIT_PHASES$ (normal and safe boot) and $PSI5_RECOVERY_INIT_PHASES$ (error recovery). Both are encoded as:

0x0: Phase II and III in succession

0x1: Skip phase II, go directly to phase III after phase I

0x2: Skip phase II and III, go directly to running mode after phase I

0x3: Reserved

11.7.1. Initialization Phase I

No sensor data is transmitted during this phase. The duration of this phase is configurable ($PSI5_INIT_I_DURATION$) in step of 1ms.

Electrical Parameter	Symbol	Min	Typ	Max	Unit	Condition
Initialization Phase I duration	DURPHI	50	100	200	ms	

Table 21: Description of data content of phase I

11.7.2. Initialization phase II

The content transferred during this phase includes mandatory fields (F1-F5) and optional fields (F6-F9) selectable ($PSI5_INIT_II_EXTRA_FIELDS$, MSbit enables F9). During this phase, the Status bit of the Payload (E0) is set to 0.

The initialization phase II can be sent more than once ($PSI5_INIT_II_REPETITIONCOUNT$).

Field	Name and NVRAM parameter	Parameter definition	Value
F1-F5: Mandatory			
F1 (D1)	Protocol Description PSI5_INIT_METAINFO	PSI5 Spec V1.x	0100
		PSI5 Spec V2.x, Data Range Initialization	0110
		PSI5 Spec V2.x, Serial Channel Initialization	0111
F2 (D2, D3)	Number of data nibbles transmitted (in phase II) PSI5_INIT_INITLENGTH	Examples: F1- F5 = 9 Nibbles F1- F9 = 32 Nibbles	Examples: 0000 1001 0010 0000
F3 (D4, D5)	Sensor Manufacturer Code PSI5_INIT_VENDORID	Information depending on the corresponding sensor type	Sensor specific information
F4 (D6, D7)	Definition of sensor type PSI5_INIT_SENSORTYPE	Information depending on the corresponding sensor type	Sensor specific information
F5 (D8, D9)	Definition of specific sensor parameters PSI5_INIT_SENSORPARAMS	Information depending on the corresponding sensor type	Sensor specific information
F6 - F9 recommended information for automotive applications			
F6 (D10, D11)	Definition of sensor specific parameters or additional information PSI5_INIT_SENSORCODE	To be specified by the sensor manufacturer	Sensor specific definition
F7 (D12-D14)	Sensor Code (Sensor application) PSI5_INIT_SENSORAPPCODE	Usage e.g. for product revision information	Sensor specific definition
F8 (D15-D18)	Sensor production Date PSI5_INIT_PRODUCTIONDATE	Binary coded Julian date: Year: 00-99 (7b) Month: 01-12 (4b) Day: 01-31 (5b)	Example 2006: 0000110 March: 0011 30: 11110
F9 (D19-D32)	Sensor Trace information E.g. production lot/line/serial number	Specified by the sensor manufacturer MLX_ID[0-2] will be sent here	Sensor specific definition

Table 22: Description of data content of phase II

11.7.3. Initialization Phase III

During this phase, the Status bit of the Payload (E0) is used as an error flag and the sensor sends one of the status messages listed in the Table below.

Status message	Sent output value
"Sensor ready"	0x1E7
"Sensor defect"	0x1F4

Table 23: Description of data content of phase III

The number of messages is configurable (PSI5_INIT_III_COUNT).

Electrical Parameter	Symbol	Min	Typ	Max	Unit	Condition
Initialization Phase III, number of messages	NBMSG	2	10	200	msgs	

Table 24: Configuration of initialization III duration

11.8. Error Reporting Mode

When the MLX90373 detects an internal error, the error is reported through the PSI5 Data Frame using the format depicted in section 11.8.1, transmitting the information described in section 11.8.2.

11.8.1. Error Reporting Data Format

The Data Frame content during error reporting depends on the Frame Format.

11.8.1.1. High Precision Frame Format

In case of High precision frame format then the format is defined by the following picture.

Start		Control			Status	Error Register (6 bits)						Status Data (10 bits)				CRC		
0	0	F0	F1	F2	1	ER0	ER1	ER2	ER3	ER4	ER5	A0 to A9				C2	C1	C0

Figure 16: Error reporting in High precision Frame Format

11.8.1.2. Low Precision Frame Format

Status Data (10 bits)	Parity
A0 to A9	P

Figure 17: Error reporting in Low precision Frame Format

11.8.2. Error Register

The error register is computed as described in the table below depending on the error bits (See section 14.2 and safety manual for more information).

Bit number in the error register	Calculation	Comment
0	GAINOOS ROCLIP HE_SYMMETRY	Aggregation
1	FIELDTOOLOW FIELDTOOHIGH	Aggregation
2	ADCCLIP ADCDROP	Aggregation
3	ADC_TEST	
4	SUP_OV_VDDA SUP_OV_V1V8	Aggregation
5	OVERTEMP	

Table 25: Error register and diagnostics

11.8.3. Status Data

The status data (D0-D9) from Figure 17 is used to transmit 10 bits status data, LSB being transmitted first, and the data value is specified in the table below.

Value(dec)	Value(Hex)	Signification
+500	0x1F4	Sensor Defect
+489	0x1E9	Sensor in service Mode
+487	0x1E7	Sensor Ready
+483	0x1E3	Reserved Sensor used

Table 26: Status data

12. End-User Programmable Items

Default values marked in the table below are subject to change.

Parameter	Description	Default standard	# bit
USER_ID[0..5]	User ID. Reference. Reserved for customers traceability	see 12.1	8
MEMLOCK	Enable NVRAM write LOCK	0x0	2
SENSOR FRONT END			
GAINMIN	Low threshold for virtual gain	0x01	8
GAINMAX	High threshold for virtual gain	0x3F	8
GAINSATURATION	Gain saturated on GAINMIN and GAINMAX	0x0	1
SENSING_MODE	Mapping fields for output angle - Rotary Stray-Field robust - Legacy mode	0x0 0x1	3
MAGNET_SREL_T[1..7]	Magnet relative sensitivity at temperature Tx. This parameter is mainly used in linear Hall mode. It is advised to keep defaults for other modes.	0xFF	8
DSP_NB_CONV ⁽²³⁾	Number of phase spinning within ADC sequence	0x0 ⁽²³⁾	2
PSI5 OUTPUT PROTOCOL			
PROTOCOL	Selection of output protocol 0x2: PSI5 Asynchronous 0x3: PSI5 Synchronous	0x3	2
PSI5_PAYLOAD_SIZE	Payload size	0x14	5
PSI5_ERRORDETECTION	Select CRC (0) or Parity (1) as error detection	0x0	1

²³ Changing default value could impact the safety metrics. Default value shall be used.

Parameter	Description	Default standard	# bit
PSI5_CYCLETIME	Select 500us (0x0) or 300us (0x1) PSI5 cycle time	0x0	2
PSI5_TRANSMITSPEED	PSI5 transmission speed selection 0: Low speed transmission (125 kbit/s) 1: High-speed transmission (189 kbit/s)	0x1	1
PSI5_FRAMEFORMAT_STD	Select low (0) or high (1) precision PSI5 frame format	0x1	1
PSI5_TRIGGER_STD	Trigger level selection 0: reduced sync pulse 1: standard sync pulse	0x1	1
PSI5_TS[1..4]_ENABLE	Enable timeslot	0x0, 0x1, 0x1, 0x0	1
PSI5_TS[1..4]_SENSORPARAM	Content of timeslot	0x0, 0x0, 0x1, 0x0	3
PSI5_TS[1..4]_STARTTIME	Start time of timeslot (TTOLDETECT excluded)	0x0, 0x175, 0x2AC, 0x0	11
PSI5_ANGULARDATA_NBITS	Number of bits to represent angular data by [1..16]	0xB	4
PSI5_ANGULARVELOCITY_NBITS	Number of bits to represent velocity data by [1..16]	0xB	4
PSI5_TEMPERATURE_NBITS	Number of bits to represent temperature data by [1..16]	0x0	4
PSI5_BFIELD_NBITS	Number of bits to represent field strength data by [1..16]	0x0	4
PSI5_RAMPROBE_NBITS	Number of bits to represent ramprobe data by [1..16]	0xF	4
PSI5_ALTERNATE_A	Alternate measurement, phase A	0x0	3
PSI5_ALTERNATE_B	Alternate measurement, phase B	0x0	3
WARM_TRIGGER_LONG	Add delay to enter PTC mode (MT7V)	0x0	1
PSI5_SYNC_ERROR_REPORT	One (0) or three (1) error frames are sent for SYNC error reporting	0x1	1
PSI5_SYNC_TO_MIN_CNT_REPORT	Number of SYNC errors to be detected before reporting	0x0	3
PSI5_SYNC_MAX_TOL	Set timeout for receiving sync pulses	0xC	8
PSI5_SYNC_MIN_TOL	Set short condition for receiving sync pulses	0xC	8
PSI5_LOWCOMMON_MODE	Low (0, 13mA) or common (1, 26mA) current modulation level	0x1	1
PSI5_REDUCEDCURRENT_MODE	Reduced current modulation level	0x0	1
FILTERING			
DSP_FILTER	Filter mode selection	0x1	2

Parameter	Description	Default standard	# bit
HYST	Hysteresis threshold for EMA filter	0x0	8
DENOISING_FILTER_ALPHA_SEL	Select the alpha parameter of the IIR filter	0x0	2
PSI5_DPI_FILTER_ENABLE	Enable DPI filter in analog interface	0x0	1
VELOCITY_FILTER_FIR	Filter selection for velocity measurement	0x1	2
VELOCITY_DENOISING_FILTER_ALPHA_SEL	Select the alpha parameter of the IIR filter of the velocity measurement	0x0	2
VELOCITY_HYST	Hysteresis threshold for EMA filter of velocity measurement	0x1	8
LINEAR TRANSFER CHARACTERISTIC			
DSP_SEL_4PTS	Set for LNR selection	0x0	1
DSP_LNR_RESX2	Set for LNR selection	0x0	1
CW	Set rotation to clockwise	0x0	1
DP	Discontinuity point	0x0000	16
CLAMPLOW	Low clamping value of output signal	0x0010	16
CLAMPHIGH	High clamping value of output signal	0xFF80	16
USEROPTION_SCALING	Enables the output scaling 0 = [0..100%] 1 = [-50%..150%]	0x1	1
LNR_S0	Slope before point A in 4-Pts LNR	-	16
LNR_A_S, LNR_B_S, LNR_C_S, LNR_D_S	Slopes after point A/B/C/D in 4-Pts LNR	-	16
LNR_A_X, LNR_B_X, LNR_C_X, LNR_D_X	X coordinates of point A/B/C/D in 4-Pts LNR	-	16
LNR_A_Y, LNR_B_Y, LNR_C_Y, LNR_D_Y	Y coordinates of point A/B/C/D in 4-Pts LNR	-	16
LNR_X[00..07]	X coordinates for the 8-Pts LNR	-	16
LNR_Y[00..07]	Y coordinates for the 8-Pts LNR Y coordinates for the 17-Pts LNR	0x4009 -	16
GAIN_ANCHOR_MID	Re-scaling before the piece-wise linearization step	0x1	1
LNR_Y[08..16]	Y coordinates for the 17-Pts LNR	- 0xBFC8	16
LNR_S0_Q15	Slope for 32-Pts LNR	-	16
LNR_DELTA_Y[01..32]	Delta Y for 32-Pts LNR	-	8
LNR_DELTA_Y_EXPAND_LOG2	Adjust the span of LNR_DELTA_Y[01..32], for 32-Pts LNR	0x0	2
WORK_RANGE_GAIN	Angle range in 17-Pts and 32-Pts LNR	0x10	8

Parameter	Description	Default standard	# bit
VELOCITY			
VELOCITY_ALGORITHM	Enable tracking loop algorithm for angular velocity measurement	0x1	1
VELOCITY_ENABLE	Enable velocity measurement	0x1	1
RAMPROBE			
RAMPROBE_PTR	RAM address to be probed	0x0000	16
DIAGNOSTICS			
DIAG_GLOBAL_EN ⁽²³⁾	Diagnostics global enable. DO NOT MODIFY!	0x1 ⁽²³⁾	1
DIAG_DEBOUNCE_STEPDOWN	Diagnostic debouncing step-down time	0x1	4
DIAG_DEBOUNCE_STEPUP	Diagnostic debouncing step-up time	0x2	4
DIAG_DEBOUNCE_THRESH	Diagnostic debouncing threshold	0x02	6
DIAG_TEMP_THR_LOW ⁽²³⁾	Temperature threshold for under-temperature diagnostic	0x08	8
DIAG_TEMP_THR_HIGH ⁽²³⁾	Temperature threshold for over-temperature diagnostic	0x88	8
DIAG_FIELDTOOLOWTHRES	Field limit under which a fault is reported	application dependant	8
DIAG_FIELDTOOHIGHTHRES	Field limit over which a fault is reported	0xFF	8
OUT_DIAG_HIZ_TIME	Transient failure reporting time. When a transient digital failure is detected, the output drivers are disabled during N ms. The time-out is calculated as: timeout = (OUT_DIAG_HIZ_TIME+1) * 4 * 1ms.	0x7	3
COLD_SAFE_STARTUP_EN	Normal (0) or full safe (1) start-up after power-on reset	0x0	1
INITIALIZATION			
PSI5_COLD_INIT_PHASES	Initialization phase configuration, after normal and safe boot	0x0	2
PSI5_RECOVERY_INIT_PHASES	Initialization phase configuration, after error recovery	0x2	2
PSI5_INIT_I_DURATION	Duration of initialization phase I	0x32	8
PSI5_INIT_II_EXTRA_FIELDS	Enable extra fields in initialization phase II	0x0	4
PSI5_INIT_II_REPETITIONCOUNT	Repetition count of initialization phase II	0x4	4
PSI5_INIT_METAINFO	Initialization phase II, protocol description	0x6	4
PSI5_INIT_INITLENGTH	Initialization phase II, number of nibbles	0x09	8
PSI5_INIT_VENDORID	Initialization phase II, vendor identification	0x06	8
PSI5_INIT_SENSORTYPE	Initialization phase II, sensor type	0x06	8

Parameter	Description	Default standard	# bit
PSI5_INIT_SENSORPARAMS	Initialization phase II, sensor specific parameters	0x00	8
PSI5_INIT_SENSORCODE	Initialization phase II, sensor manufacturer	0x00	8
PSI5_INIT_SENSORAPPCODE	Initialization phase II, sensor application specific code	0x000	12
PSI5_INIT_PRODUCTIONDATE	Initialization phase II, production data	0x0000	16
PSI5_INIT_III_COUNT	Message count for initialization phase III	0x2	8

Table 27: End-user Programmable Items

12.1. End-User Identification Items

Parameter	Description	Default Standard	# bit
MLX_ID0	X-Y position on the wafer (8 bits each)	-	16
MLX_ID1	Wafer ID (5 bits); Lot ID [10..0] (11 bits)	-	16
MLX_ID2	Lot ID [16..11] (6 bits); Fab ID (4 bits); Test Database ID (6 bits)	-	16
CHIP_VERSION	IMC shape version identifier Order code 10x Order code 30x	0 1	7
TEST_STATUS	Status of MLX final test (0: Fail and 1: Pass)	1	1
USER_ID0	Program '1' at last step of FT to indicate a bin 1	1	8
USER_ID1		0	8
USER_ID2	Die version (1 = ABA)	1	8
USER_ID3		2	8
USER_ID4		0	8
USER_ID5		0	8

Table 28: End-user identification items

13. Description of End-User Programmable Items

13.1. Output Transfer Characteristic

13.1.1. Selection

The transfer function (LNR) is selectable (DSP_SEL4PTS and DSP_LNR_RESX2) as per the Table 29.

DSP_SEL4PTS	DSP_LNR_RESX2	LNR type
1	0	4Pts
1	1	8Pts
0	0	17Pts
0	1	32Pts

Table 29: Output Transfer Characteristic Selection

13.1.2. Programmable Items

Output Mode	LNR type				Value	Unit
	4pts	8pts	17pts	32pts		
USEROPTION_SCALING	•	•	•		0: 0 ... 100 1: -50 ... 150	%
CW	•	•	•	•	0: CCW 1: CW	LSB
DP	•	•	•	•	0 ... 359.9999	Deg.
CLAMPLOW	•	•	•	•	0 ... 100	%
CLAMPHIGH	•	•	•	•	0 ... 100	%
LNR_x_X with x=A, B, C, D	•				0 ... 359.9999	Deg.
LNR_x_Y with x=A, B, C, D	•				see USEROPTION_SCALING	%
LNR_S0 LNR_x_S with x=A, B, C, D	•				-17 ... 0 ... 17	%/Deg.
LNR_Xx with x=0-7		•			0 ... 359.9999	Deg.
LNR_Yx with x=0-7		•	•		see USEROPTION_SCALING	%
LNR_Yx with x=8-16			•			
LNR_DELTA_Yx with x=01-32				•	0 ... 100%	selectable offset range
LNR_S0_Q15				•	0 ... 0.555	% /Deg. (scales with working range)
LNR_DELTA_Y_EXPAND_LOG2				•	-3.125... 3.125 -6.25...6.25 -12.5... 12.5 -25... 25	%
GAIN_ANCHOR_MID				•	Always use "1"	
WORK_RANGE_GAIN			•	•	-01x code: 11.29 ... 180 -03x code: 22.59 ... 360	Deg.

Table 30: Programmable items: Output transfer characteristic

13.1.3. Enable Scaling Parameter

The parameter USEROPTION_SCALING enables to double the scale of Y coordinates linearization parameters, see the Table 31. This is valid for all Output Linear Characteristic except the 32 segments one.

USEROPTION_SCALING	LNR_Y min value	LNR_Y max value
0	0%	100%
1	-50%	150%

Table 31: Y coordinates scaling

13.1.4. CLOCKWISE Parameter

The CLOCKWISE parameter defines the magnet rotation direction (CW).

- CCW is the defined by 1-8-9-16 pin order direction for the TSSOP-16 package.
- CW is defined by the reverse direction: 16-9-8-1 pin order direction for the TSSOP-16 package.

Refer to the drawing in the sensitive spot positioning (see 18.1.3 and 18.2.3)

13.1.5. Discontinuity Point or Zero Degree Point

The Discontinuity Point (DP) defines the 0 Deg. point on the circle. The DP places the origin at any location of the trigonometric circle. The DP is used as reference for all the angular measurements.

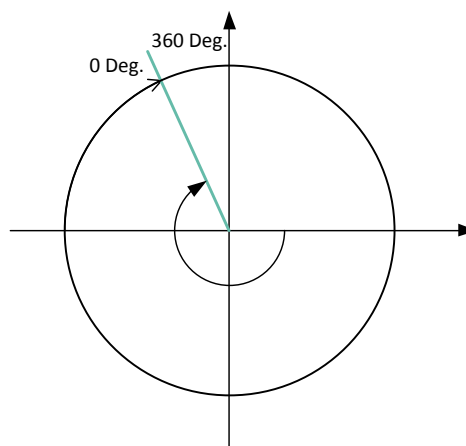

Figure 18: The placement of the DP is programmable

13.1.6. CLAMPING Parameters

The clamping levels are two independent values to limit the output voltage range. The CLAMPLOW parameter adjusts the minimum output voltage level. The CLAMPHIGH parameter sets the maximum output voltage level. Both parameters have 16 bits of adjustment and are available for all LNR modes.

13.1.7. WORKING RANGE (PWL only)

The range for the angle can be selected using the WORK_RANGE_GAIN parameter, which applies a fixed gain to the transfer characteristics. Using WORK_RANGE_GAIN parameter, the anchor point is kept at 180° and the range is symmetrically set around this value. It creates a zoom-in of the angle around this point. WORK_RANGE_GAIN is coded on 8 bits where the 4 MSB defines the integer part and the 4 LSB the fractional parts (in power of twos). Therefore, the following equation applies to define the angle range W:

$$w = \frac{16 \times FA}{WORK_RANGE_GAIN}$$

with FA=180° for -10x code and FA=360° for -30x code.

Both minimal and maximal angles are then defined by:

$$\theta_{min} = 180^\circ - \frac{w}{2} ; \theta_{max} = 180^\circ + \frac{w}{2}$$

where θ_{min} corresponds to the angle yielding 0% output and θ_{max} the angle giving a 100% output.

Following table gives the extreme values as example:

WORK_RANGE_GAIN	code	Range (w)	θ_{min}	θ_{max}	Δx 17 pts	Δx 32 pts
0x10	-10x	180°	90°	270°	11.25°	5.63°
	-30x	360°	0°	360°	22.50°	11.25°
0xFF	-10x	11.29°	0°	360°	0.71°	0.35°
	-30x	22.59°	168.7°	191.3°	1.41°	0.71°

Table 32: Working range defined with GAIN parameter and option code

Outside of the working range, the output will remain at clamping levels.

13.1.8. 4-Pts LNR Parameters

The LNR parameters, together with the clamping values, fully define the relation (the transfer function) between the digital angle and the output signal.

The shape of the MLX90373 four points transfer function from the digital angle value to the digital output is described in Figure 19. Seven segments can be programmed but the clamping levels are necessarily flat.

Two, three, or even six calibration points are then available, reducing the overall non-linearity of the IC by almost an order of magnitude each time. Three or six calibration point will be preferred by customers

looking for excellent non-linearity figures. Two-point calibrations will be preferred by customers looking for a cheaper calibration set-up and shorter calibration time.

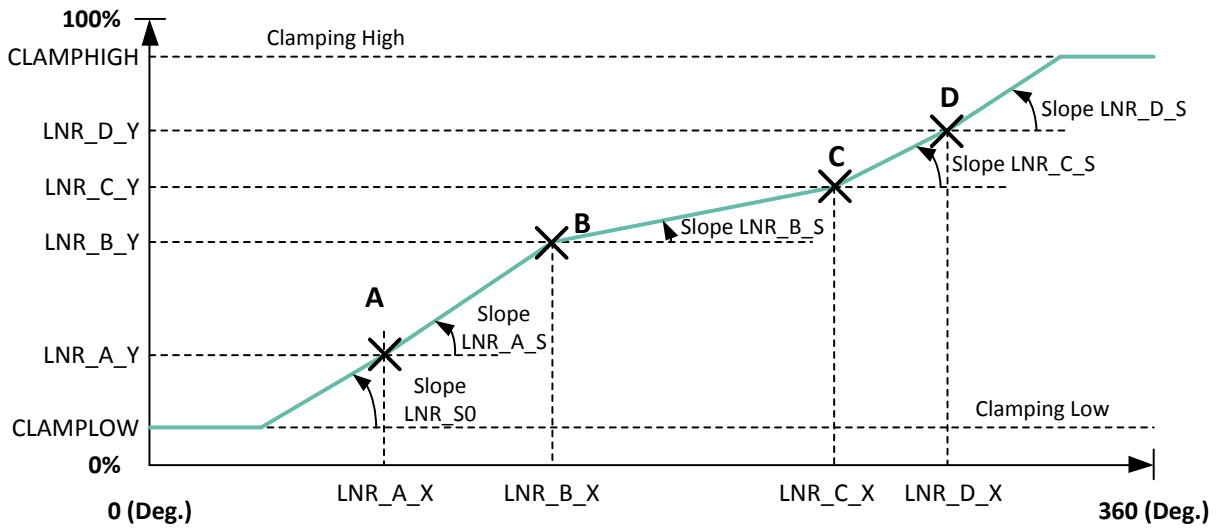

Figure 19: 4-Points Transfer function

13.1.9. 8-Pts LNR Parameters

The 8-Pts LNR parameters, together with the clamping values, fully define the relation (the transfer function) between the digital angle and the output signal.

The shape of the MLX90373 eight points transfer function from the digital angle value to the output voltage is described in Figure 20. Eight calibration points [LNR_X0...7, LNR_Y0...7] together with 2 fixed points at the extremity of the range ([0°, 0%] ; [360°, 100%]) divides the transfer curve into 9 segments. Each segment is defined by 2 points and the values in between is calculated by linear interpolation.

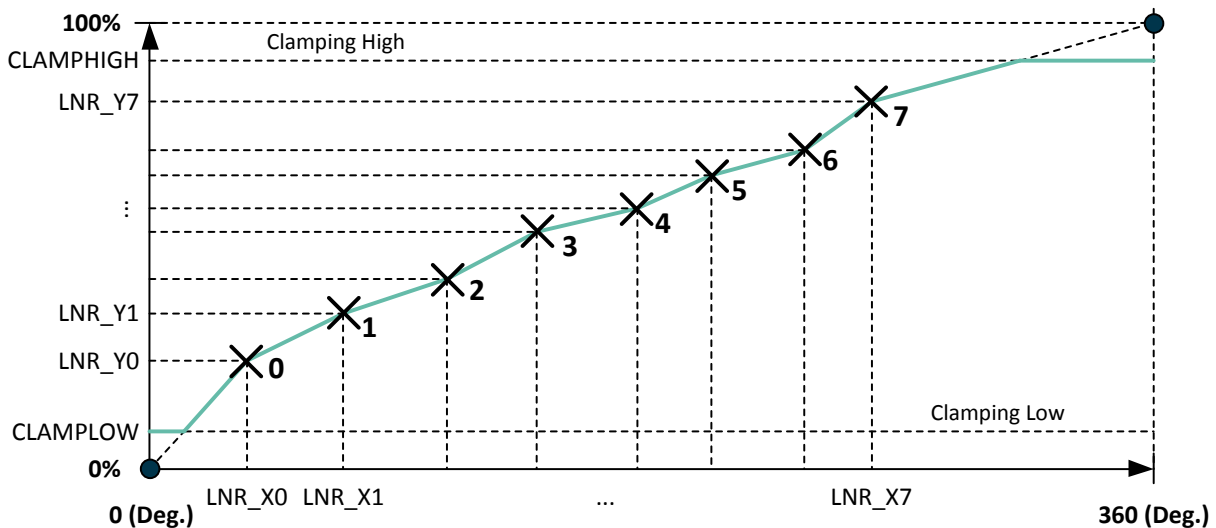

Figure 20: 8-Points Transfer function

13.1.10. 17-Pts LNR Parameters (PWL)

The LNR parameters, together with the clamping values, fully define the relation (the transfer function) between the digital angle and the output signal.

The shape of the MLX90373 seventeen points transfer function from the digital angle value to the output voltage is described in Figure 21. In the 17-Pts mode, the output transfer characteristic is Piece-Wise-Linear (PWL).

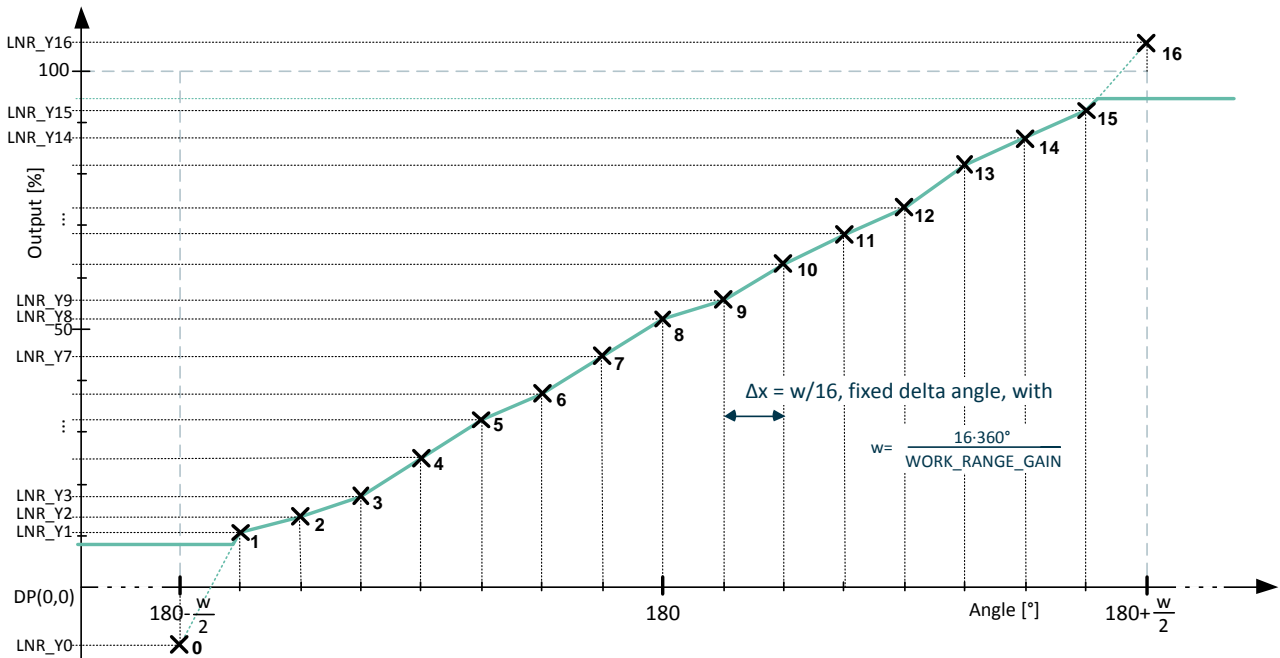

Figure 21: 16-Segments calibration transfer function

All the Y-coordinates can be programmed from -50% up to +150% to allow clamping in the middle of one segment (like on the figure), but the output value is limited to CLAMPLOW and CLAMPHIGH values.

Between two consecutive points, the output characteristic is interpolated.

13.1.11. 32-Pts LNR Parameters (PWL)

The LNR parameters, together with the clamping values, fully define the relation (the transfer function) between the digital angle and the output signal.

The shape of the MLX90373 thirty-two points transfer function from the digital angle value to the output voltage is described in Figure 22. In the 32-Pts mode, the output transfer characteristic is Piece-Wise-Linear (PWL).

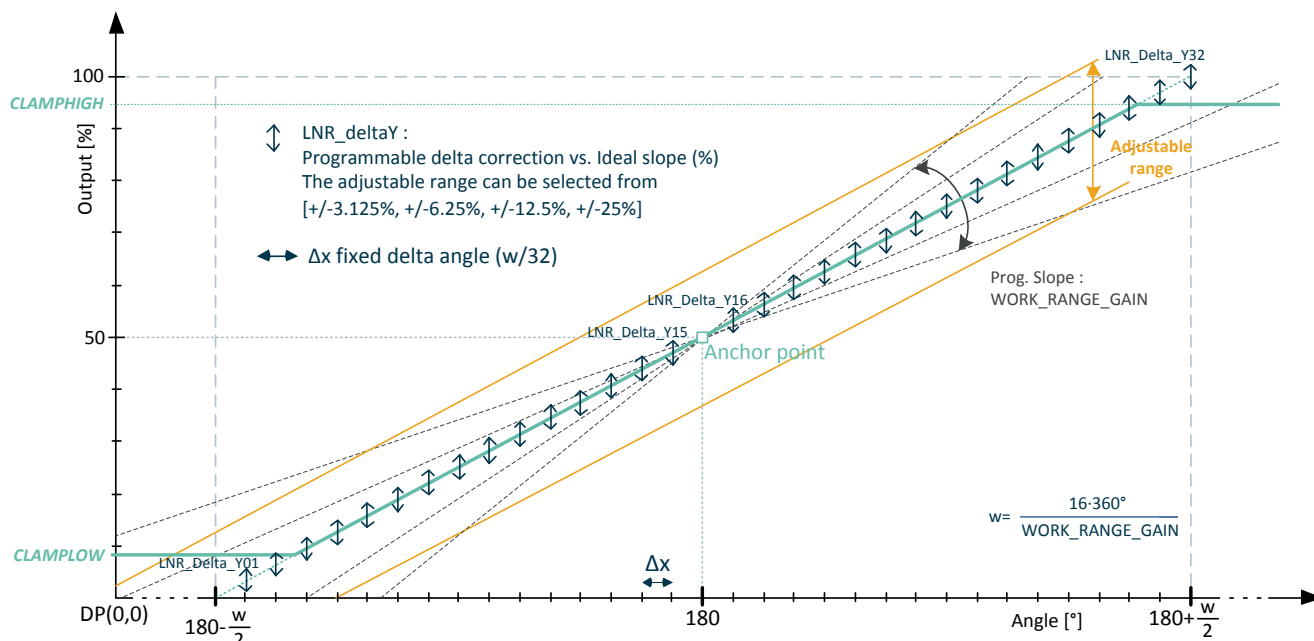

Figure 22: 32-Segments calibration transfer function

The points are spread evenly across the working range (see 13.1.7 for working range selection). The Y-coordinates can be offset from the ideal characteristic within an adjustable range defined by LNR_DELTA_Y_EXPAND_LOG2. The available values are summarized in the table below. All LNR_delta_Y## parameters are encoded in a fractional signed 8-bit value.

LNR_DELTA_Y_EXPAND_LOG2	Offset range %	Delta range [LSB12]	Resolution [LSB12]
0	±3.125	-128..127	1
1	±6.25	-256..254	2
2	±12.5	-512..508	4
3	±25	-1024..1016	8

13.2. Sensor Front-End

Parameter	Value
SENSING_MODE	[0 - 4]
GAINMIN	[0 - 63]
GAINMAX	[0 - 63]
GAINSATURATION	[0, 1]

Table 33: Programmable items: sensor front-end

13.2.1. SENSING MODE

The SENSING_MODE parameter defines which sensing mode and fields are used to calculate the angle. The different possibilities are described in the tables below.

This 2 bits value selects the first (B1) and second (B2) field components according the table below.

SENSING_MODE	B1	B2	Application
0	ΔX	ΔY	Angular Rotary Stray-Field Immune
1	X	Y	Legacy / XY Angular Rotary
2	Y	Z	Legacy / YZ Angular Rotary
3	X	Z	Legacy / XZ Angular Rotary

Table 34: Programmable items: sensing modes

13.2.2. GAINMIN and GAINMAX Parameters

GAINMIN and GAINMAX define the thresholds on the gain code outside which the fault “GAIN out of Spec.” is set. If GAINSATURATION is set, then the virtual gain code is saturated at GAINMIN and GAINMAX, and no Diagnostic fault is set since the saturations applies before the diagnostic check.

13.3. Filter

The MLX90373 includes 2 types of programmable filters:

- Low Pass FIR Filter.
- Exponential moving average Filter.

Filter	Angular	Angular velocity	parameter	Value
Low Pass	•		DSP_FILTER	[0 - 2]
		•	VELOCITY_FILTER_FIR	
Exponential moving average	•		HYST	[0 - 255]
		•	VELOCITY_HYST	[0 - 1]
		•	VELOCITY_DENOISING_FILTER_ALPHA_SEL	[0 - 3]
•		DENOISING_FILTER_ALPHA_SEL		

Table 35: Filtering configuration

13.3.1. Low Pass FIR Filters

The MLX90373 features 2 FIR filter modes controlled with DSP_FILTER or VELOCITY_FILTER_FIR. The transfer function is described below:

$$y_n = \frac{1}{\sum_{i=0}^j a_i} \sum_{i=0}^j a_i x_{n-i}$$

For information, the filters characteristic is given in the following table:

DSP_FILTER or VELOCITY_FILTER_FIR parameter	0	1	2
Type	Disable	Finite Impulse Response	
Coefficients a_i	1	11	1111
Description	No filter	ExtraLight	Light
DSP_cycle (j= nb of taps)	1	2	4
Efficiency RMS (dB)	0	3.0	6.0

Table 36: FIR Filter Characteristics

13.3.2. Exponential Moving Average (IIR) Filter

The HYST parameter is a threshold to activate/de-activate the exponential moving average filter.

- The output value of the IC is updated with the applied filter when the digital step is smaller than the programmed HYST parameter value.
- The output value is updated without applying the filter when the increment is bigger than the threshold.

The VELOCITY_HYST parameter is Digital hysteresis (hide the small variation but lower resolution)
0: no hysteresis (default), IIR filter disabled

This filter reduces therefore the noise but still allows a fast step response for bigger angle/position changes. The threshold must be programmed to a value close to the internal magnetic angle noise level. (1 LSB = $8 * 360 / 2^{16}$).

$$y_n = a * x_n + (1-a) * y_{n-1} \quad \begin{matrix} x_n = \text{Angle} \\ y_n = \text{Output} \end{matrix}$$

The filter characteristic is selectable.

DENOISING_FILTER_ALPHA_SEL or VELOCITY_DENOISING_FILTER_ALPHA_SEL parameter	0	1	2	3
Coefficients a	0.75	0.5	0.25	0.125
Efficiency RMS (dB)		2.4	4.2	

Table 37: IIR Filter characteristics

13.4. Programmable Diagnostics Settings

13.4.1. Diagnostics Global Enable

DIAG_GLOBAL_EN should be kept to its default value (1) to retain all functional safety abilities of the MLX90373. This feature shall not be disabled.

13.4.2. DIAG Debouncing

A debouncing algorithm is available for analog diagnostic reporting (See section 14.2)

1. The error is reported only if it is active for some user-defined amount of time.
2. The error reporting stays enabled on error recovery for some user-defined amount of time.

The error is reported in the output, using predefined reporting level, reporting time and debouncing time. The debouncing algorithm is parameterized by the NVRAM parameters as per the Table 38

NVRAM Parameter	Description	Default
DIAGDEBOUNCE_STEPDOWN	Decrement values for debouncer counter	1
DIAGDEBOUNCE_STEPUP	Increment value for debouncer counter	5
DIAG_DEBOUNCE_THRESH	Threshold for debouncer counter to enter diagnostic mode	15

Table 38: Programmable diagnostic - DIAG debouncing

The debouncing algorithm will increment the debouncing counter w/ the STEPUP value in case of an diagnostic error, and decrement w/ STEPDOWN in case of no analog diagnostic error. If the debouncing counter is higher than the DEBOUNCE THRESHOLD, then an error is reported and the debouncing counter is clamped to the DEBOUNCE THRESHOLD value.

The debouncing time and recovery time are defined as per the Table 39.

Parameter	Min	Typ.	Max
Diagnostic Test Interval (DTI)		9.4ms	
Debouncing Time	DTI * (CEILING (Threshold / UP) - 1)		DTI * CEILING (Threshold / UP)
Recovery time	DTI * CEILING (Threshold / DOWN)		DTI * (CEILING (Threshold / DOWN) + 1)

Table 39: Programmable diagnostic - debouncing & reporting time

13.4.3. Over/Under Temperature Diagnostic

DIAG_TEMP_THR_HIGH defines the threshold for over temperature detection and is compared to the linearized value of the temperature sensor T_{LIN} . DIAG_TEMP_THR_LOW defines the threshold for under temperature detection and is compared to the linearized value of the temperature sensor T_{LIN} .

14. Functional Safety

14.1. Safety Manual

The safety manual, available upon request, contains the necessary information to integrate the MLX90373 component in a safety related item, as Safety Element Out-of-Context (SEooC).

In particular it includes:

- The description of the Product Development lifecycle tailored for the Safety Element.
- An extract of the Technical Safety concept.
- The description of Assumptions-of-Use (AoU) of the element with respect to its intended use, including:
 - assumption on the device safe state;
 - assumptions on fault tolerant time interval and multiple-point faults detection interval;
 - assumptions on the context, including its external interfaces;
- The description of safety analysis results at the device level useful for the system integrator; HW architectural metrics and description of dependent failures initiators.
- The description and the result of the functional safety assessment process; list of confirmation measures and description of the independency level.

14.2. Safety Mechanisms

The MLX90373 provides numerous self-diagnostic features (safety mechanisms). Those features increase the robustness of the IC functionality as it will prevent the IC to provide erroneous output signal in case of internal or external failure modes (“fail-safe”).

Legend

● High coverage

○ Medium coverage

ANA : Analog hardware failure reporting, described in the safety manual

DIG : Digital hardware failure reporting, described in the safety manual

* : Diagnostic Cycle Time

At Startup : HW fault present at time zero is detected before a first frame is transmitted.

Table 40: Self Diagnostic Legend

Category and safety mechanism name	Front-end	ADC	DSP	Back-end	Support Func.	Module & Package	DCT*	Reporting mode	At startup
Signal-conditioning (AFE, External Sensor) Diagnostic	●	●				●		ANA	
Magnetic Signal Conditioning Voltage Test Pattern	●	○	○				DCT_Ana	ANA	
Magnetic Signal Conditioning Rough Offset Clipping check	●		○				DCT_Ana	ANA	NO
Magnetic Signal Conditioning Gain Monitor	●		○			●	DCT_Ana	ANA	YES
Magnetic Signal Conditioning Gain Clamping	●		○			●	DCT_Ana	ANA	YES
Mag. Sig. Cond. Failure control by the chopping technique	●						Continuous	n/a	YES
External Sensor Sig. Cond. Voltage Valid Range Check	●					●	DCT_Ana	ANA	YES
External Sensor Sig. Cond. Frequency Valid Range Check	●					●	DCT_Ana	ANA	YES
A/D Converter Test Pattern		●					DCT_Ana	ANA	
ADC Conversion errors & Overflow Errors		●					DCT_Ana	ANA	YES
Flux Monitor (Specific to Rotary mode)	●	○				●	DCT_Ana	ANA	YES
Digital-circuit Diagnostic			●					DIG	
RAM Parity, 1 bit per 16 bits word, ISO D.2.5.2			●				<10us	DIG	YES
ROM Parity, 1 bit per 16 bits word, ISO D.2.5.2			●				<10us	DIG	YES
NVRAM 16 bits signature (run-time) ISO D.2.4.3 by means of SW additive checksum			●					DIG	
NVRAM Double Error Detection ECC ISO			●				DCT_Dig	DIG	
Logical Monitoring of program sequence ISO D.2.9.3 via Watchdog "IWD" (cpu clock) ISO D2.9.2			●		○		Tiwd	DIG	
Watchdog "AWD" (separate clock) ISO D2.9.1			●		○		Tawd	DIG	
CPU Errors "Invalid Address", "Wrong opcode"			●		○		<10us	DIG	YES
ADC Interface Checksum		●					DCT_Dig	DIG	NO

Category and safety mechanism name	Front-end	ADC	DSP	Back-end	Support Func.	Module & Package	DCT*	Reporting mode	At startup
DSP Test Pattern (atan2)			●		○		DCT_Dig	DIG	
Critical ports monitoring			●				DCT_Dig	DIG	NO
Communication Interface Diagnostic				●				DIG	
PSI5 block: Protection against re-configuration at run-time				●			<10us	DIG	
PSI5 frame counter				●			1 frame	n/a	n/a
System-level diagnostic					●	●		ANA	
Supply Voltage Monitors VS_OV, VDDA_OV, V1V8_OV					●	●	DCT_Ana	ANA	
Supply Voltage Monitors VS_UV, VDDA_UV					●	●	DCT_Ana	DIG	
External Supply Overvoltage Monitor VS_OV					●	●	2.1ms	DIG	YES
Digital Supply under-voltage monitor (Power-on reset)					●	●	<10us	DIG	YES
Supply Bias Current Monitor					●		DCT_Ana	ANA	
Overheating monitor	○	○	○	○	○	●	DCT_Ana	ANA	YES
Warning/Reporting Mechanisms							n/a	n/a	
HW Error Controller			●	●	●		n/a	DIG	YES
HW Fail-safe mode with timeout			●	●	●		n/a	DIG	YES
Analog-type Error management	●	●			●		n/a	ANA	
Safe start-up mode			●		●		n/a	DIG	n/a
Mechanisms executed at start-up only									
RAM March-C HW Test at start-up			●		●		n/a	DIG	YES

Table 41: MLX90373 List of Self Diagnostics with Characteristics

15. Recommended Application Diagrams

15.1. Wiring in TSSOP-16 Package

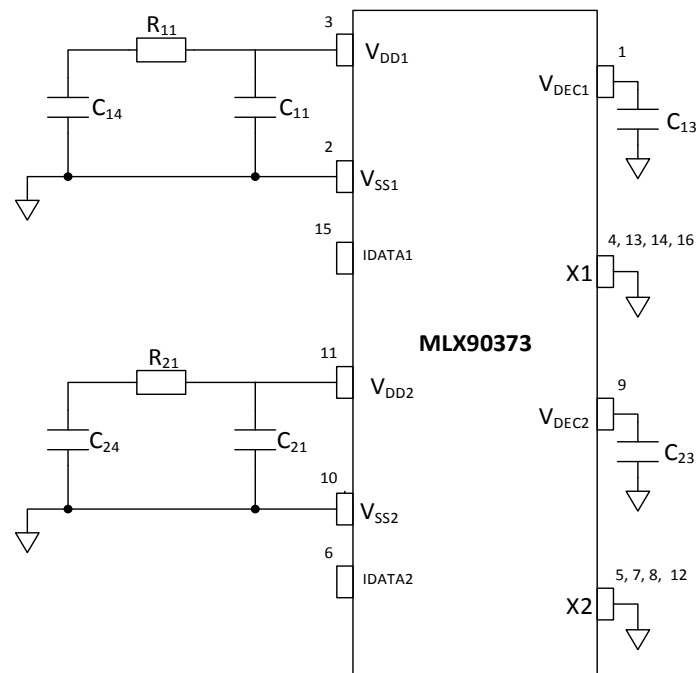

Figure 23: Recommended wiring for the MLX90373 in TSSOP-16 package (dual die)

Output	Compact PCB routing			EMC robust PCB routing			Remarks
	Min	Typ.	Max	Min	Typ.	Max	
Analog Output							
C11, C21	9 nF	10 nF	24nF	9 nF	10 nF	24nF	Close to the pin depending on the number of sensor on the psi5 bus
C13, C23	47 nF	100 nF	220 nF	47 nF	100 nF	220 nF	Close to the pin
C14, C24	-	-	-	500 pF	-	1 nF	Connector Side
R11, R21	-	-	-	0 Ω	-	10 Ω	

Table 42: TSSOP-16 recommended components, values shown represent the typical value of the standard devices; additional ±10% tolerance is accepted

15.2. Wiring in DMP-4 Package

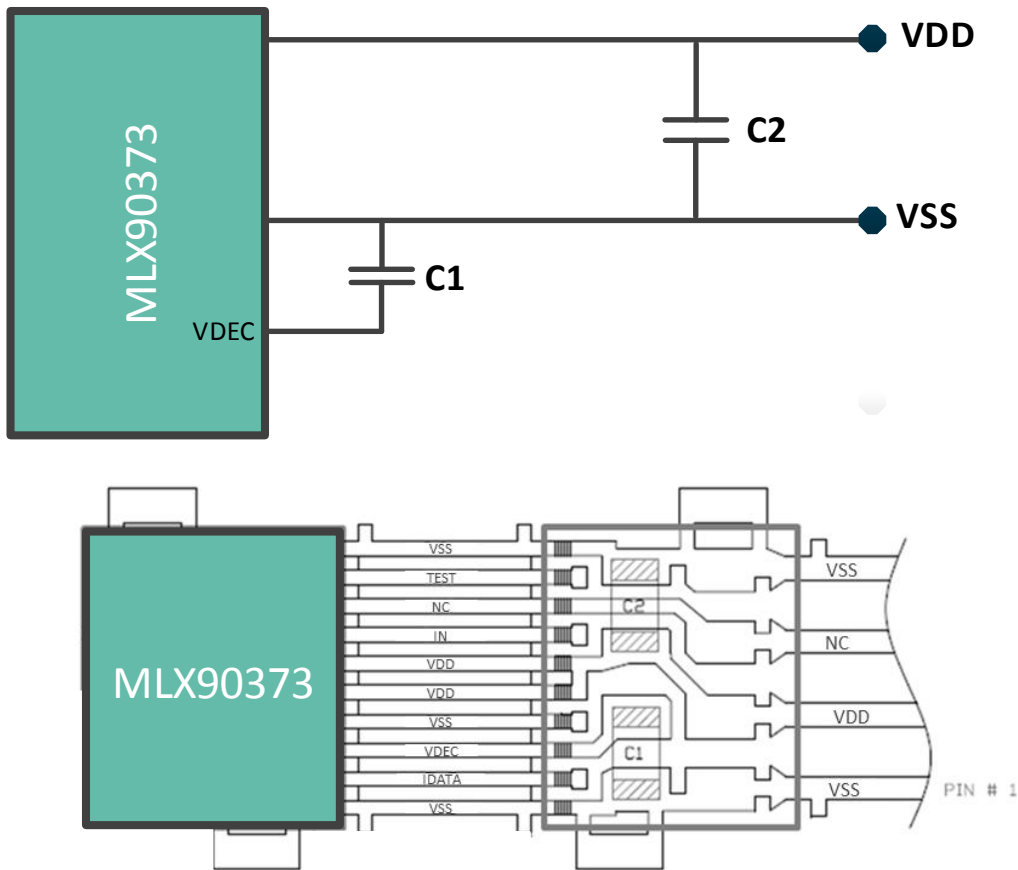

Figure 24: Capacitor configurations and recommended wiring for the MLX90373 in DMP-4 package

In this DMP-4 version, keep pin4 connected to Vss.

Ordering code	C1	C2
MLX90373GVS-ABA-10x-xx	100 nF	10 nF
MLX90373GVS-ABA-30x-xx	100 nF	10 nF

Table 43: DMP-4 capacitors configuration

16. Standard Information Regarding Manufacturability Of Melexis Products With Different Soldering Processes

Our products are classified and qualified regarding soldering technology, solderability and moisture sensitivity level according to standards in place in Semiconductor industry.

For further details about test method references and for compliance verification of selected soldering method for product integration, Melexis recommends reviewing on our web site the General Guidelines soldering recommendation (<http://www.melexis.com/en/quality-environment/soldering>)

For all soldering technologies deviating from the one mentioned in above document (regarding peak temperature, temperature gradient, temperature profile etc), additional classification and qualification tests have to be agreed upon with Melexis.

For package technology embedding trim and form post-delivery capability, Melexis recommends consulting the dedicated trim&forming recommendation application note: lead trimming and forming recommendations (<http://www.melexis.com/en/documents/documentation/application-notes/lead-trimming-and-forming-recommendations>).

Melexis is contributing to global environmental conservation by promoting lead free solutions. For more information on qualifications of RoHS compliant products (RoHS = European directive on the Restriction Of the use of certain Hazardous Substances) please visit the quality page on our website: <http://www.melexis.com/en/quality-environment>.

17. ESD Precautions

Electronic semiconductor products are sensitive to Electro Static Discharge (ESD). Always observe Electro Static Discharge control procedures whenever handling semiconductor products.

18. Package Information

18.1. TSSOP-16 Package

18.1.1. TSSOP-16 - Package Dimensions

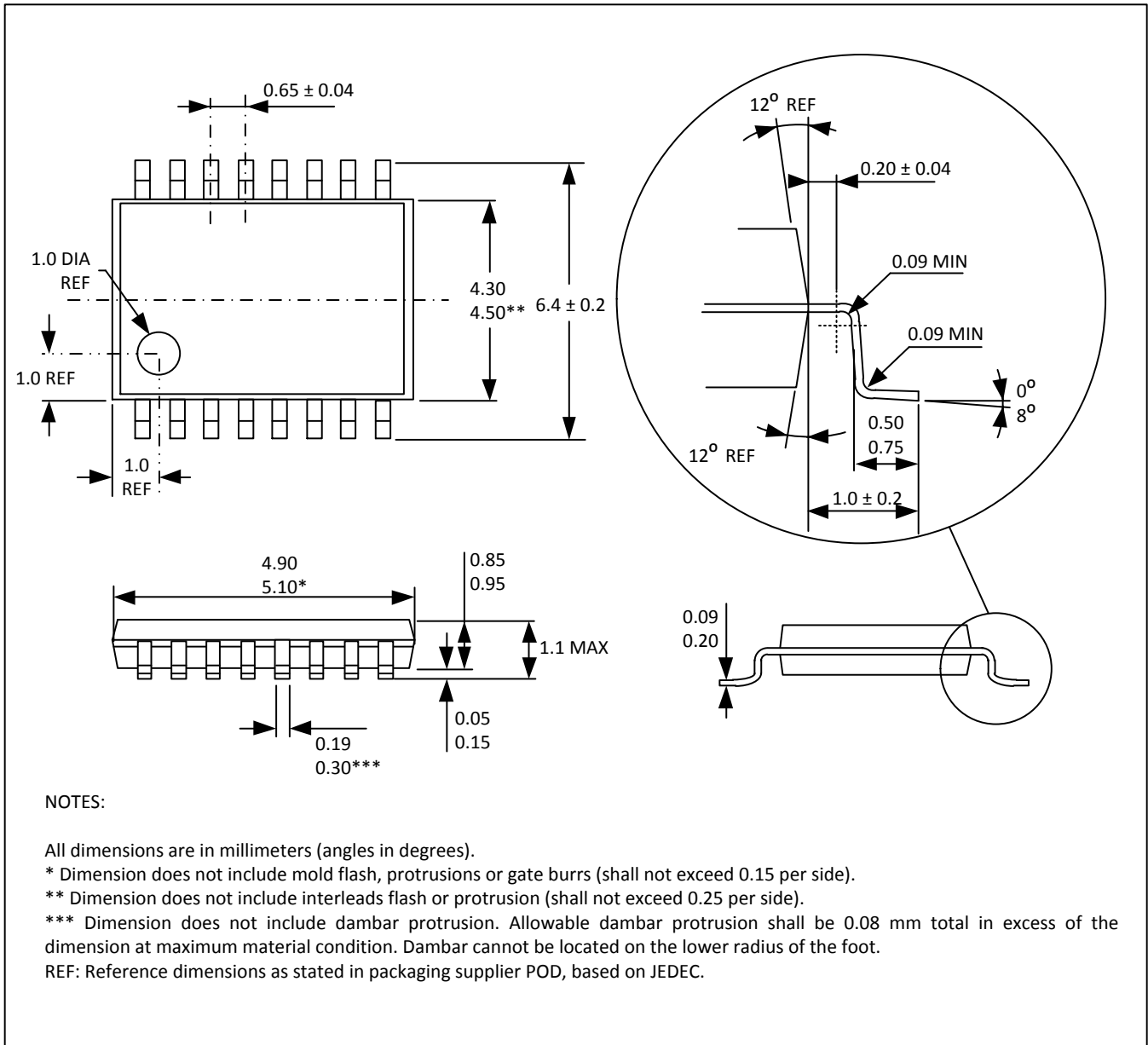

Figure 25: TSSOP-16 Package Dimensions

18.1.2. TSSOP-16 - Pinout and Marking

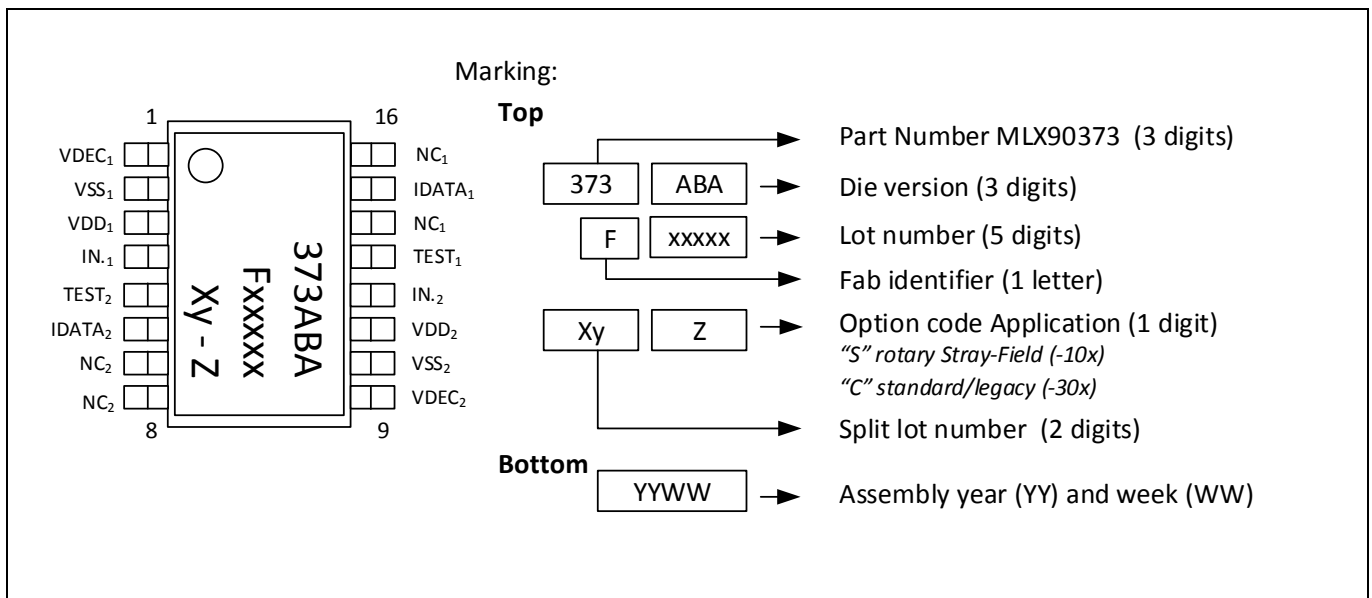

Figure 26: TSSOP-16 pinout & marking

18.1.3. TSSOP-16 - Sensitive Spot Positioning

18.1.3.1. Angular Stray-Field Immune & Standard/Legacy Mode

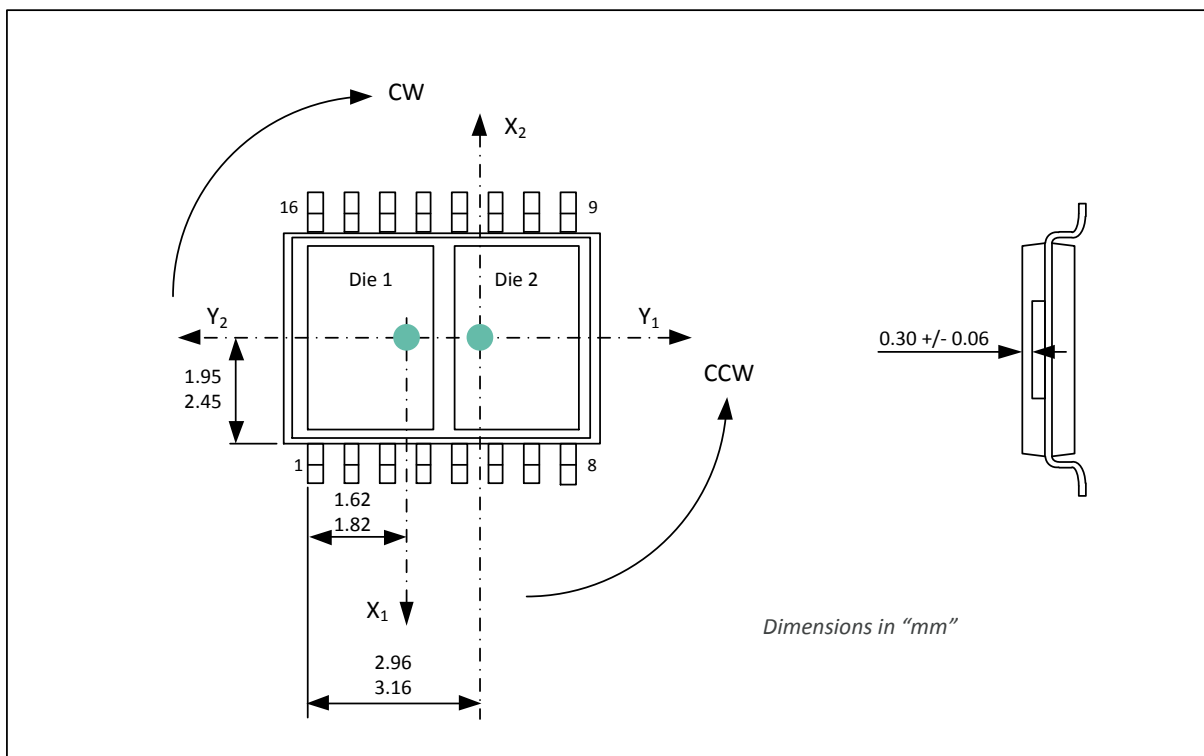

Figure 27: TSSOP-16 sensitive spot position

18.1.4. TSSOP-16 - Angle Detection

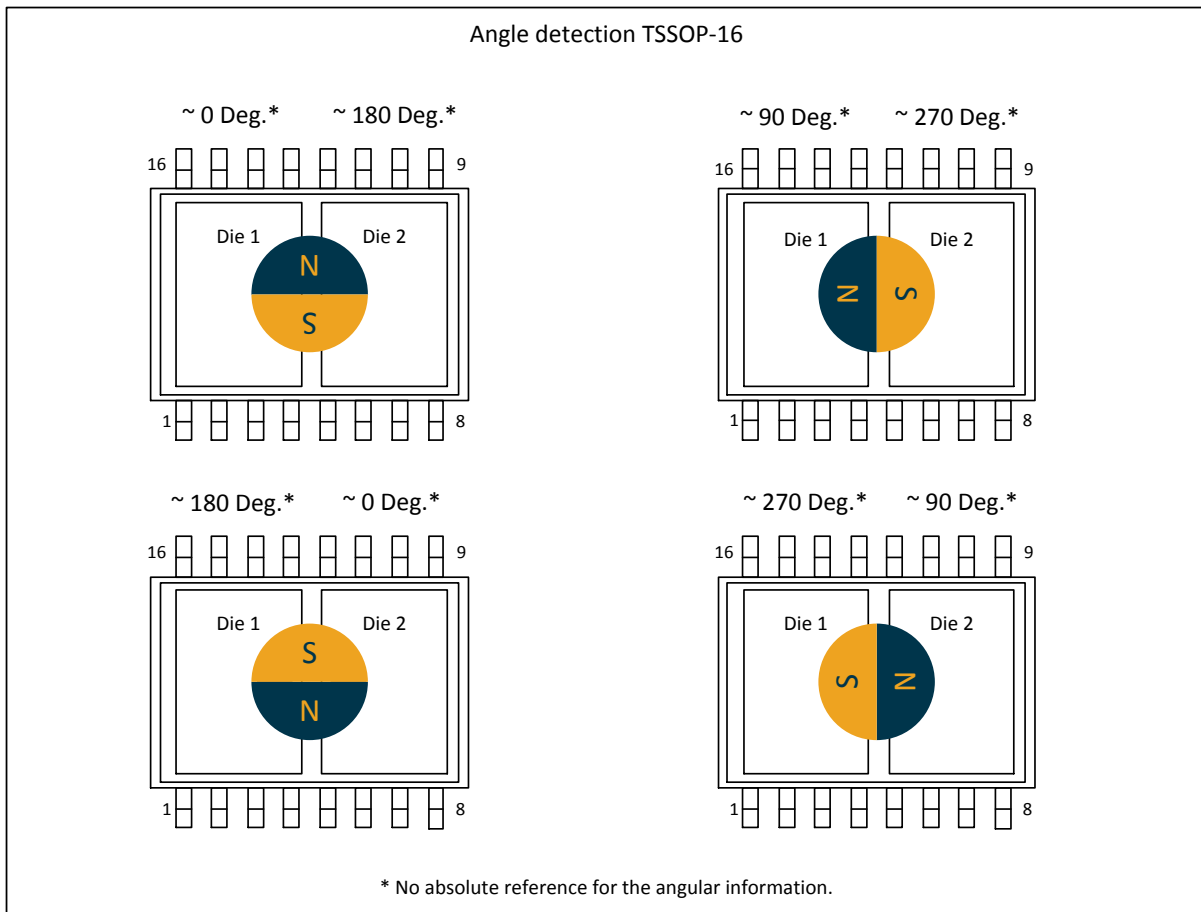

Figure 28: TSSOP-16 angle detection

The MLX90373 is an absolute angular position sensor. Note however that the linearity error (See section 9 Accuracy Specification) does not include the error linked to the absolute reference 0 Deg., which can be fixed in the application through the discontinuity point.

18.1.5. TSSOP-16 – Thermal Performances

The table below describe the thermal behaviour of available packages following JEDEC EIA/JESD 51.X standard.

Package	Junction to case - θ_{jc}	Junction to ambient - θ_{ja} (JEDEC 1s2p board)	Junction to ambient - θ_{ja} (JEDEC 1s0p board)
TSSOP-16	27.6 K/W	99.1 K/W	137 K/W

Table 44: TSSOP-16 Package Thermal Performances

18.2. DMP-4 Package

18.2.1. DMP-4 - Package Dimensions

18.2.1.1. DMP-4 - Package Outline Dimensions (POD) – Straight Leads

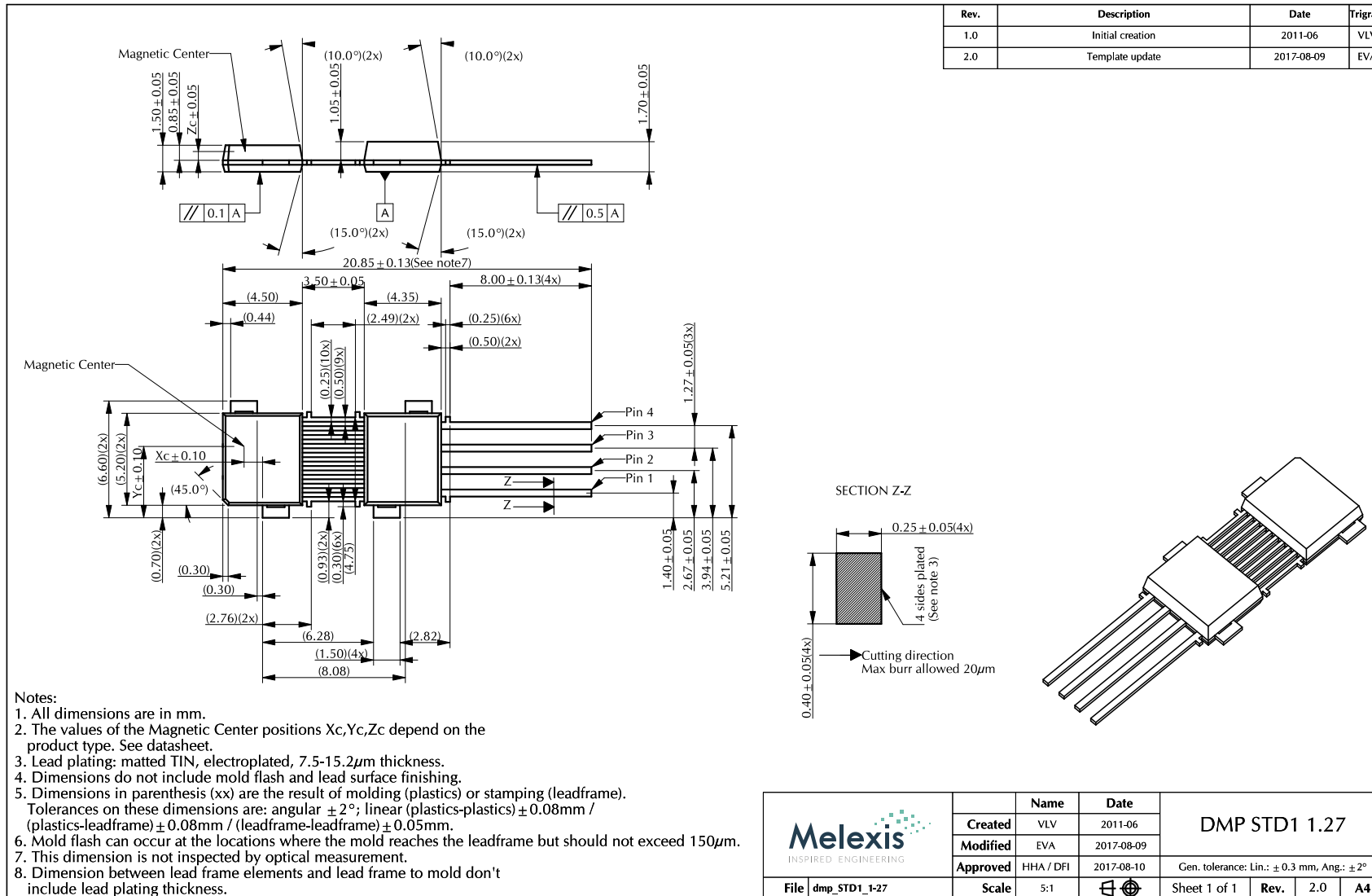

Figure 29: DMP-4 information for straight leads

18.2.1.2. DMP-4 - Package Outline Dimensions (POD) – STD2 2.54

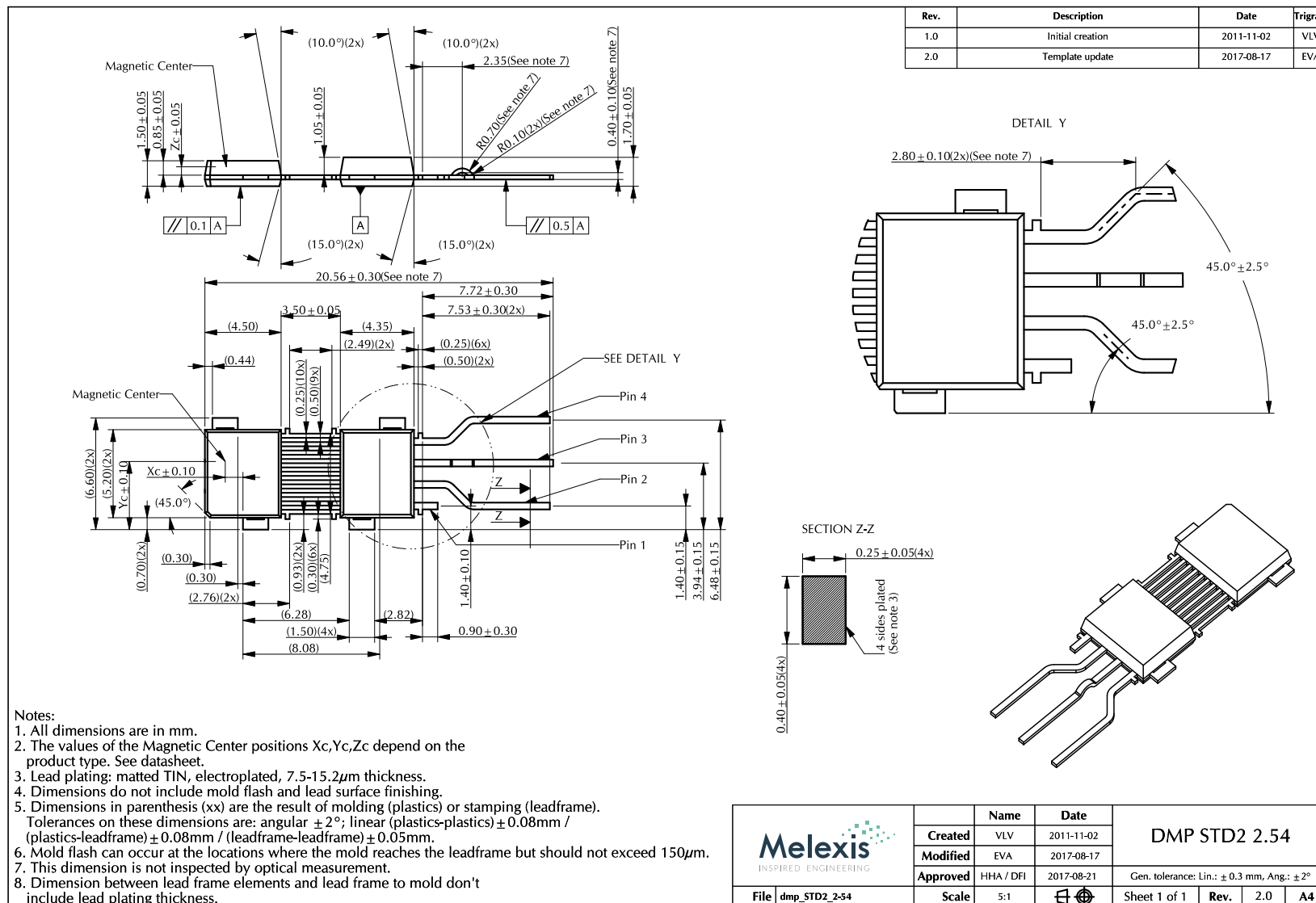

Figure 30: DMP-4 STD2 2.54 Package Outline Drawing

18.2.1.3. DMP-4 - Package Outline Dimensions (POD) – STD4 2.54

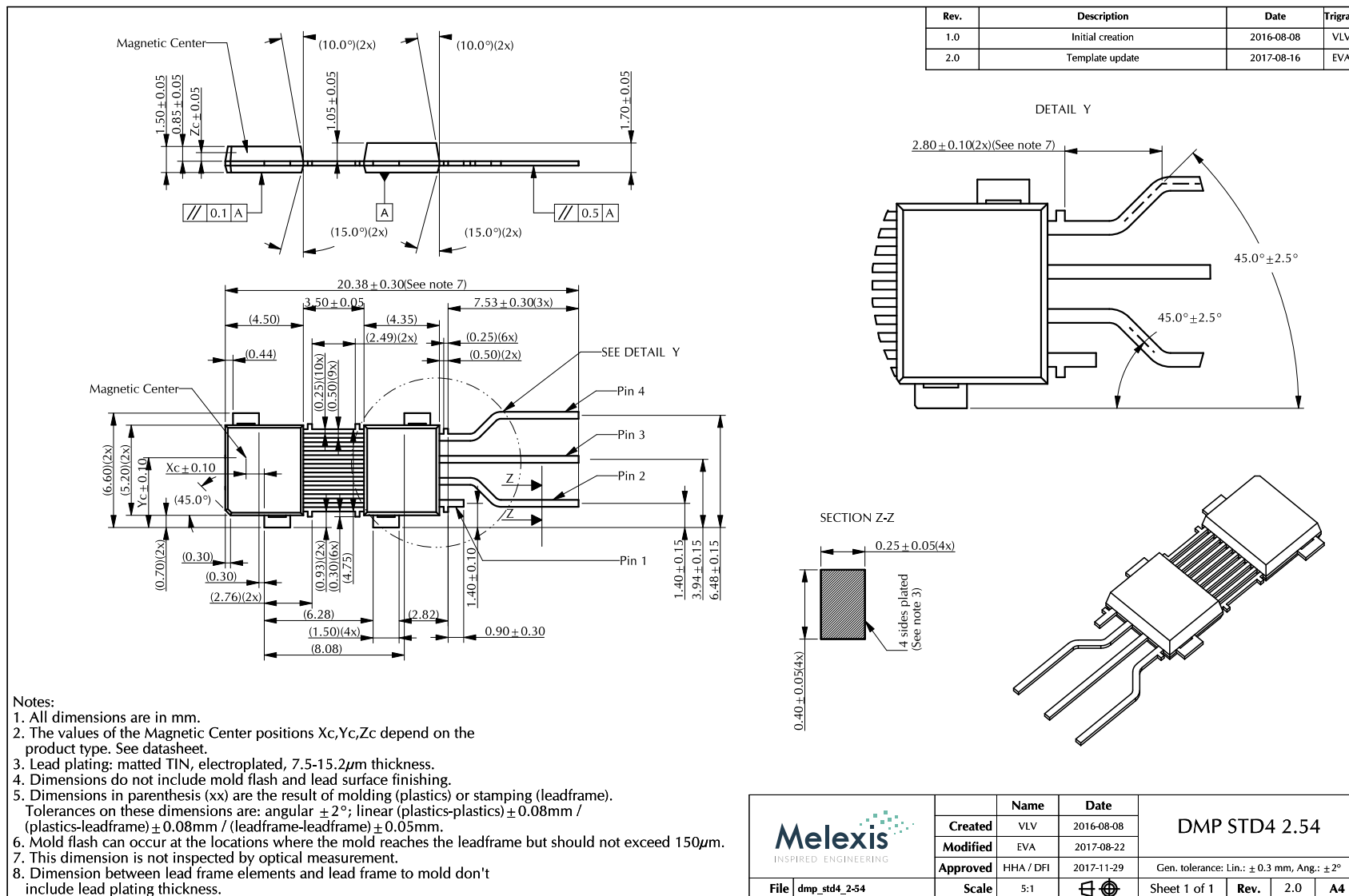

Figure 31: DMP-4 STD4 2.54 Package Outline Drawing

18.2.2. DMP-4 - Pinout and Marking

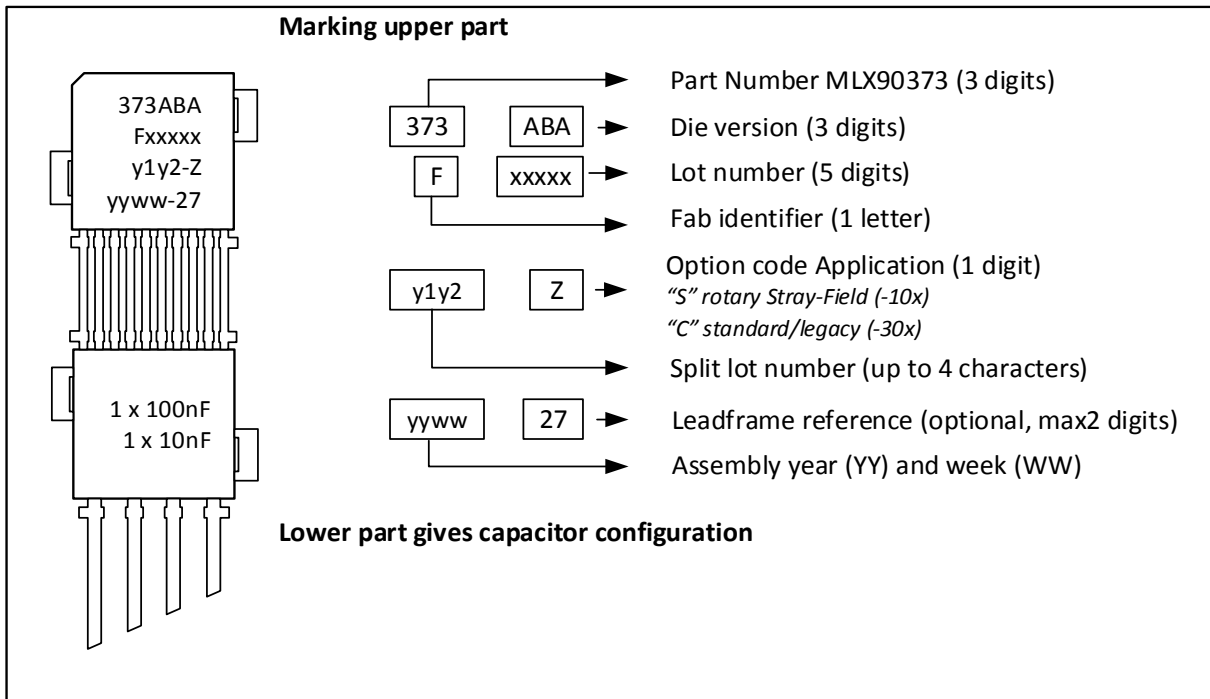

Figure 32: DMP-4 pinout and marking

18.2.3. DMP-4 - Sensitive Spot Positioning & Sense direction

18.2.3.1. Angular Stray-Field Immune or Standard/legacy

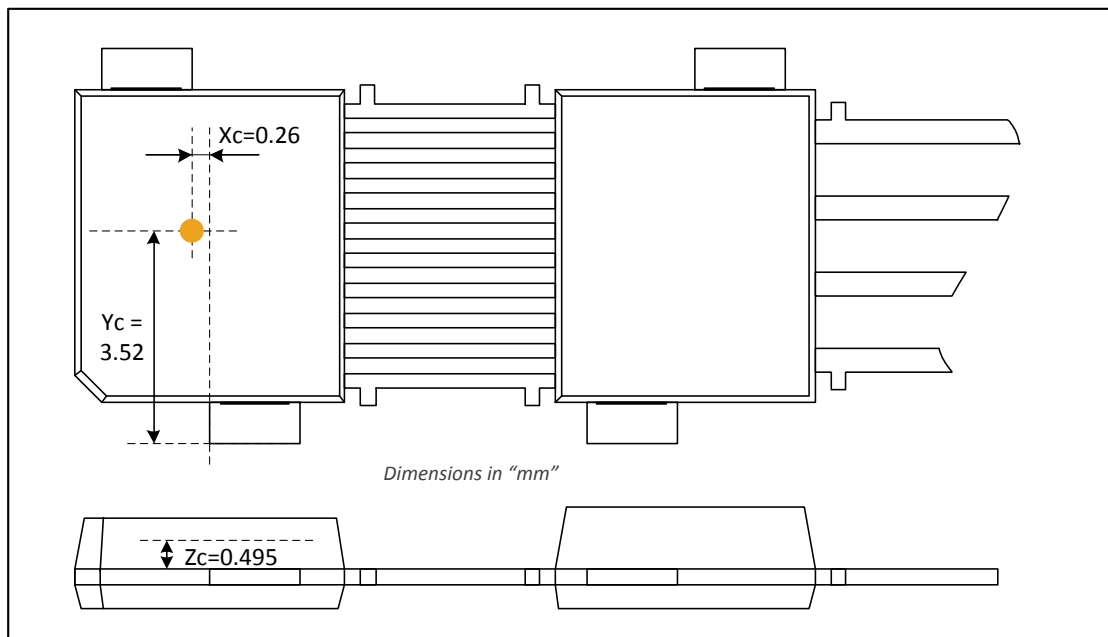

Figure 33: DMP-4 sensitive spot for angular position Stray-Field immune and standard/legacy modes

18.2.4. DMP-4 - Angle Detection

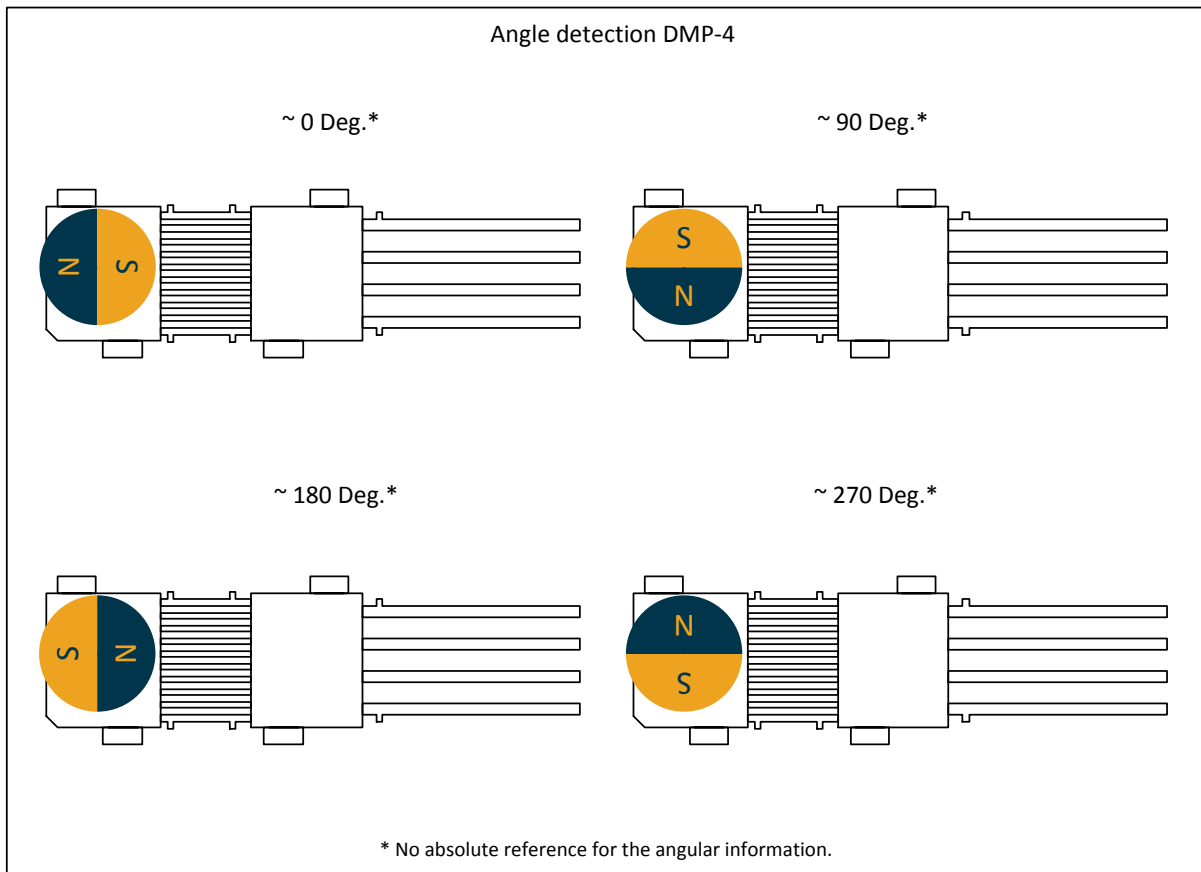

Figure 34: DMP-4 angle detection

The MLX90373 is an absolute angular position sensor. Note however that the linearity error (See section 9 Accuracy Specification) does not include the error linked to the absolute reference 0 Deg., which can be fixed in the application through the discontinuity point.

18.2.5. DMP-4 - Thermal Performances

The table below describe the thermal behaviour of available packages following JEDEC EIA/JESD 51.X standard.

Package	Junction to case - θ_{jc}	Junction to ambient - θ_{ja} (JEDEC 1s2p board)	Junction to ambient - θ_{ja} (JEDEC 1s0p board)
DMP-4	32.2 K/W	88.7 K/W	done without PCB ⁽²⁴⁾

Table 45: DMP-4 Package Thermal Performances

²⁴ DMP-4 as PCB-less solution has been evaluated in a typical application case. Values for this package are given as informative.

19. Contact

For the latest version of this document, go to our website at www.melexis.com.

For additional information, please contact our Direct Sales team and get help for your specific needs:

Europe, Africa	Telephone: +32 13 67 04 95
	Email : sales_europe@melexis.com
Americas	Telephone: +1 603 223 2362
	Email : sales_usa@melexis.com
Asia	Email : sales_asia@melexis.com

20. Disclaimer

The information furnished by Melexis herein ("Information") is believed to be correct and accurate. Melexis disclaims (i) any and all liability in connection with or arising out of the furnishing, performance or use of the technical data or use of the product(s) as described herein ("Product") (ii) any and all liability, including without limitation, special, consequential or incidental damages, and (iii) any and all warranties, express, statutory, implied, or by description, including warranties of fitness for particular purpose, non-infringement and merchantability. No obligation or liability shall arise or flow out of Melexis' rendering of technical or other services.

The Information is provided "as is" and Melexis reserves the right to change the Information at any time and without notice. Therefore, before placing orders and/or prior to designing the Product into a system, users or any third party should obtain the latest version of the relevant information to verify that the information being relied upon is current.

Users or any third party must further determine the suitability of the Product for its application, including the level of reliability required and determine whether it is fit for a particular purpose.

The Information is proprietary and/or confidential information of Melexis and the use thereof or anything described by the Information does not grant, explicitly or implicitly, to any party any patent rights, licenses, or any other intellectual property rights.

This document as well as the Product(s) may be subject to export control regulations. Please be aware that export might require a prior authorization from competent authorities.

The Product(s) are intended for use in normal commercial applications. Unless otherwise agreed upon in writing, the Product(s) are not designed, authorized or warranted to be suitable in applications requiring extended temperature range and/or unusual environmental requirements. High reliability applications, such as medical life-support or life-sustaining equipment are specifically not recommended by Melexis.

The Product(s) may not be used for the following applications subject to export control regulations: the development, production, processing, operation, maintenance, storage, recognition or proliferation of 1) chemical, biological or nuclear weapons, or for the development, production, maintenance or storage of missiles for such weapons; 2) civil firearms, including spare parts or ammunition for such arms; 3) defense related products, or other material for military use or for law enforcement; 4) any applications that, alone or in combination with other goods, substances or organisms could cause serious harm to persons or goods and that can be used as a means of violence in an armed conflict or any similar violent situation.

The Products sold by Melexis are subject to the terms and conditions as specified in the Terms of Sale, which can be found at <https://www.melexis.com/en/legal/terms-and-conditions>.

This document supersedes and replaces all prior information regarding the Product(s) and/or previous versions of this document.

Melexis NV © - No part of this document may be reproduced without the prior written consent of Melexis. (2019)

ISO/TS 16949 and ISO14001 Certified