

### Brief Description

The ZSSC3218 is a sensor signal conditioner (SSC) integrated circuit for high-accuracy amplification and analog-to-digital conversion of a differential or pseudo-differential input signal. Designed for high-resolution sensor module applications, the ZSSC3218 can perform offset, span, and 1<sup>st</sup> and 2<sup>nd</sup> order temperature compensation of the measured signal. Developed for correction of resistive bridge or absolute voltage sensors, it can also provide a corrected temperature output measured with an internal sensor.

The measured and corrected sensor values are provided at the digital output pins, which can be configured as I<sup>2</sup>C™\* (≤ 3.4MHz) or SPI (≤ 20MHz). Digital compensation of signal offset, sensitivity, temperature, and non-linearity is accomplished via a 26-bit internal digital signal processor (DSP) running a correction algorithm. Calibration coefficients are stored on-chip in a highly reliable, non-volatile, multiple-time programmable (MTP) memory. Programming the ZSSC3218 is simple via the serial interface. The interface is used for the PC-controlled calibration procedure, which programs the set of calibration coefficients in memory. The ZSSC3218 provides accelerated signal processing, increased resolution, and improved noise immunity in order to support high-speed control, safety, and real-time sensing applications with the highest requirements for energy efficiency.

### Features

- Flexible, programmable analog front-end design; up to 18-bit analog-to-digital converter (ADC)
- Fully programmable gain amplifier for optimizing sensor signals: gain range 6.6 to 216 (linear)
- Internal auto-compensated temperature sensor
- Digital compensation of individual sensor offset; 1<sup>st</sup> and 2<sup>nd</sup> order digital compensation of sensor gain as well as 1<sup>st</sup> and 2<sup>nd</sup> order temperature gain and offset drift
- Programmable interrupt operation
- High-speed sensing: e.g. 16-bit conditioned sensor signal measurement rate >500s<sup>-1</sup>
- Typical sensor elements can achieve an accuracy of better than ±0.10% FSO\*\* at -40 to 85°C

### Benefits

- Integrated 26-bit calibration math digital signal processor (DSP)
- Fully corrected signal at digital output
- Layout customized for die-die bonding with sensor for high-density chip-on-board assembly
- One-pass calibration minimizes calibration costs
- No external trimming, filter, or buffering components required
- Highly integrated CMOS design
- Integrated reprogrammable non-volatile memory
- Excellent for low-voltage and low-power battery applications
- Optimized for operation in calibrated resistive (e.g., pressure) sensor or calibrated absolute voltage (e.g., thermopile) sensor modules

### Physical Characteristics

- Supply voltage range: 1.68V to 3.6V
- Current consumption: 1.0mA (operating mode)
- Sleep State current: 20nA (typical)
- Temperature resolution: <0.003K/LSB
- Best-in-class energy-efficiency:
  - with 16-bit resolution: <140pJ/step
  - with 18-bit resolution: <50pJ/step
- Operation temperature: -40°C to +85°C
- Small die size
- Delivery options: die for wafer bonding

\* I<sup>2</sup>C™ is a trademark of NXP.

\*\* FSO = Full Scale Output.

### ZSSC3218 Application Example

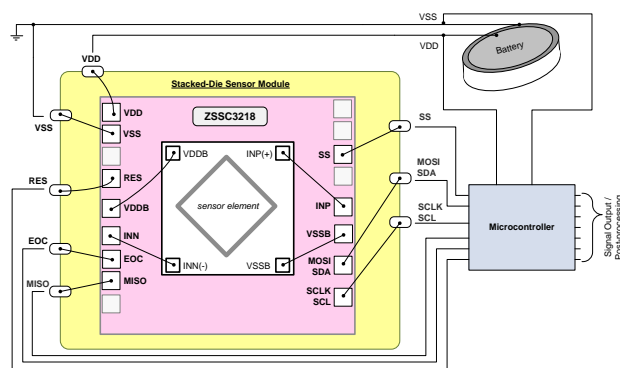

**ZSSC3218 Block Diagram**

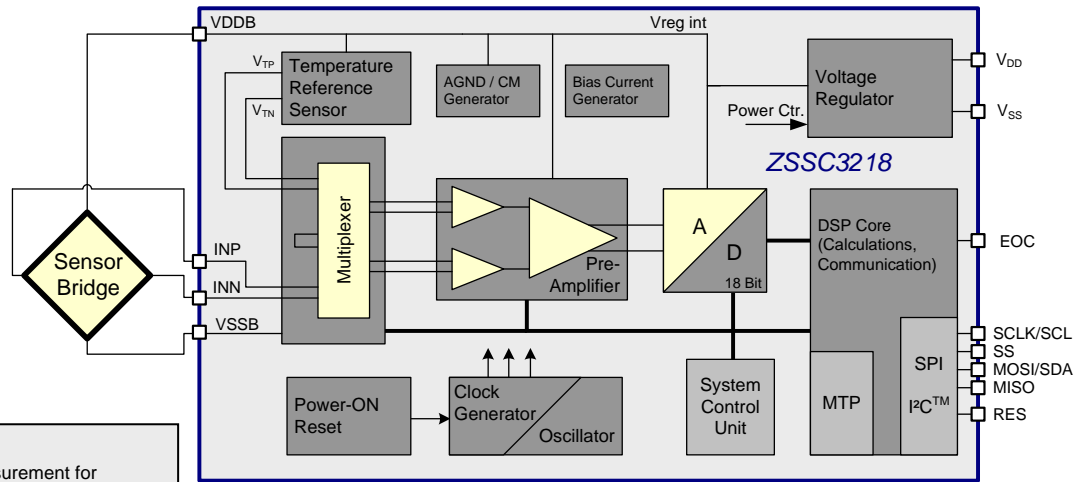

- Applications**
- ❖ Barometric altitude measurement for portable navigation or emergency call systems
  - ❖ Altitude measurement for car navigation
  - ❖ Weather forecast
  - ❖ Fan control
  - ❖ Industrial, pneumatic, and liquid pressure
  - ❖ High-resolution temperature measurements
  - ❖ Object-temperature radiation (via thermopile)

Sales Code	Description	Package
ZSSC3218BI1B	Die—temperature range: -40°C to +85 °C; thickness 304µm	Unsawn wafer
ZSSC3218BI2B	Die—temperature range: -40°C to +85 °C; thickness 725µm (w/o backlapping)	Unsawn wafer
ZSSC3218BI3R ES	PQFN24—temperature range: -40°C to +85 °C; <i>engineering samples</i>	Packaged die

## Table of Contents

1	IC Characteristics .....	6
1.1.	Absolute Maximum Ratings .....	6
1.2.	Operating Conditions .....	6
1.3.	Electrical Parameters .....	7
1.4.	Power Supply Rejection Ratio (PSRR) vs. Frequency .....	9
2	Circuit Description .....	10
2.1.	Brief Description .....	10
2.2.	Signal Flow and Block Diagram .....	10
2.3.	Analog Front End .....	11
2.3.1.	Amplifier .....	11
2.3.2.	Analog-to-Digital Converter .....	13
2.3.3.	Selection of Gain and Offset – Sensor System Dimensioning .....	15
2.3.4.	Temperature Measurement .....	16
2.3.5.	External Sensor Supply: Bridge Sensors .....	16
2.3.6.	External Sensor: Absolute Voltage Source Sensors .....	16
2.4.	Digital Section .....	17
2.4.1.	Digital Signal Processor (DSP) Core .....	17
2.4.2.	MTP Memory .....	17
2.4.3.	Clock Generator .....	17
2.4.4.	Power Supervision .....	17
2.4.5.	Interface .....	17
3	Functional Description .....	18
3.1.	Power Up .....	18
3.2.	Measurements .....	18
3.3.	Interrupt (EOC Pin) .....	19
3.4.	Operational Modes .....	21
3.4.1.	SPI/I <sup>2</sup> C™ Commands .....	24
3.5.	Communication Interface .....	27
3.5.1.	Common Functionality .....	27
3.5.2.	SPI .....	28
3.5.3.	I <sup>2</sup> C™ .....	30
3.6.	Multiple Time Programmable (MTP) Memory .....	32
3.6.1.	Programming Memory .....	32
3.6.2.	Memory Contents .....	33
3.7.	Calibration Sequence .....	41
3.7.1.	Calibration Step 1 – Assigning Unique Identification .....	41
3.7.2.	Calibration Step 2 – Data Collection .....	42

3.7.3.	Calibration Step 3a) – Coefficient Calculations .....	43
3.7.4.	Calibration Step 3b) – Post-Calibration Offset Correction .....	43
3.7.5.	SSC Measurements .....	43
3.8.	The Calibration Math .....	44
3.8.1.	Bridge Signal Compensation .....	44
3.8.2.	Temperature Signal Compensation .....	47
3.8.3.	Measurement Output Data Format .....	48
4	Package Information and Pad Assignments .....	49
5	Quality and Reliability .....	53
6	Ordering Sales Codes .....	53
7	Related Documents .....	53
8	Glossary .....	54
9	Document Revision History .....	55

## Table of Figures

Figure 2.1	ZSSC3218 Functional Block Diagram, Resistive-Bridge Sensor .....	10
Figure 2.2	ZSSC3218 Functional Block Diagram, Voltage-Source Sensor .....	11
Figure 2.3	Gain and Offset Setup .....	16
Figure 3.1	Interrupt Functionality .....	20
Figure 3.2	Operational Flow Chart: Power Up .....	22
Figure 3.3	Operational Flow Chart: Command Mode and Normal Mode (Sleep and Cyclic) .....	23
Figure 3.4	SPI Configuration CPHA=0 .....	28
Figure 3.5	SPI Configuration CPHA=1 .....	29
Figure 3.6	SPI Command Request .....	29
Figure 3.7	SPI Read Status .....	30
Figure 3.8	SPI Read Data .....	30
Figure 3.9	I <sup>2</sup> C™ Command Request .....	31
Figure 3.10	I <sup>2</sup> C™ Read Status .....	31
Figure 3.11	I <sup>2</sup> C™ Read Data .....	31
Figure 4.1	ZSSC3218 Pad Placement .....	49
Figure 4.2	General PQFN24 Package Dimensions .....	51

## List of Tables

Table 1.1	Maximum Ratings .....	6
Table 1.2	Operating Conditions .....	6
Table 1.3	Requirements for VDD Power-on Reset .....	7

Table 1.4	Electrical Parameters .....	7
Table 2.1	Amplifier Gain: Stage 1 .....	12
Table 2.2	Amplifier Gain: Stage 2 .....	12
Table 2.3	Gain Polarity .....	12
Table 2.4	ADC Conversion Times for a Single Analog-to-Digital Conversion .....	13
Table 2.5	ADC Offset Shift .....	14
Table 2.6	Typical Conversion Times vs. Noise Performance with Full Sensor Signal Conditioning for AZSM, SM, AZTM, and TM (Bridge-Type Sensor) .....	14
Table 3.1	SPI/I <sup>2</sup> C™ Commands .....	24
Table 3.2	Get_Raw Commands .....	26
Table 3.3	General Status Byte .....	27
Table 3.4	Mode Status .....	28
Table 3.5	MTP Memory Content Assignments .....	33
Table 3.6	Measurement Results of ADC Raw Measurement Request (two's complement) .....	48
Table 3.7	Calibration Coefficients (Factors and Summands) in Memory (sign-magnitude) .....	48
Table 3.8	Output Results from SSC-Correction Math or DSP—Sensor and Temperature .....	48
Table 3.9	Interrupt Thresholds TRSH1 and TRSH2—Format as for SSC-Correction Math Output .....	48
Table 4.1	Pad Assignments .....	50
Table 4.2	Die Connection and Bond Parameter .....	50
Table 4.3	Physical Package Dimensions .....	51
Table 4.4	Pin Assignments PQFN24 .....	52

# 1 IC Characteristics

## 1.1. Absolute Maximum Ratings

Note: The absolute maximum ratings are stress ratings only. The ZSSC3218 might not function or be operable above the recommended operating conditions. Stresses exceeding the absolute maximum ratings might also damage the device. In addition, extended exposure to stresses above the recommended operating conditions might affect device reliability. IDT does not recommend designing to the “Absolute Maximum Ratings.”

**Table 1.1 Maximum Ratings**

PARAMETER	SYMBOL	Min	TYP	MAX	UNITS
Voltage Reference	V <sub>SS</sub>	0		0	V
Analog Supply Voltage	V <sub>DD</sub>	-0.4		3.63	V
Voltage at all Analog and Digital IO Pins	V <sub>A_IO</sub> , V <sub>D_IO</sub>	-0.5		V <sub>DD</sub> +0.5	V
Input Current into any Pin except RES, SS <sup>1), 2)</sup>	I <sub>IN</sub>	-100		100	mA
Electrostatic Discharge Tolerance – Human Body Model (HBM1) <sup>3)</sup>	V <sub>HBM1</sub>	±4000		-	V
Storage Temperature	T <sub>STOR</sub>	-50		125	°C
1) Latch-up current limit for RES, ZMDI-test and SS: ±70mA. 2) Latch-up resistance; reference for pin is 0V. 3) HBM1: C = 100pF charged to V <sub>HBM1</sub> with resistor R = 1.5kΩ in series based on MIL 883, Method 3015.7. ESD protection referenced to the Human Body Model is tested with devices in ceramic dual in-line packages (CDIP) during product qualification.					

## 1.2. Operating Conditions

The reference for all voltages is V<sub>SS</sub>.

**Table 1.2 Operating Conditions**

PARAMETER	SYMBOL	MIN	TYP	MAX	UNIT
Supply Voltage	V <sub>DD</sub>	1.68	-	3.6	V
VDD Rise Time	t <sub>VDD</sub>			200	μs
Bridge Current <sup>1)</sup>	I <sub>VDDDB</sub>			1.8	mA
				16.5	
Operation Temperature Range	T <sub>AMB</sub>	-40	-	85	°C
External (Parasitic) Capacitance between VDDDB and VSS	CL	0.01		50	nF
1) Power supply rejection is reduced if a current in the range of 16.5mA > I <sub>VDDDB</sub> > 1.8mA is drawn out of VDDDB.					

A dynamic power-on-reset circuit is implemented in order to achieve minimum current consumption in idle mode. The VDD low level and the subsequent rise time and VDD rising slope must meet the requirements in Table 1.1 to guarantee an overall IC reset; lower VDD low levels allow slower rising of the subsequent on-ramp of VDD. Other combinations might also be possible. For example, the reset trigger can be influenced by increasing the power-down time and lowering the VDD rising slope requirement. Alternatively, the RES pin can be connected and used to control safe resetting of the ZSSC3218. RES is active-low; a VDD-VSS-VDD transition at the RES pin leads to a complete IC reset.

**Table 1.3 Requirements for VDD Power-on Reset**

PARAMETER	SYMBOL	MIN	TYP	MAX	UNIT
Power Down Time (duration of VDD Low Level)	$t_{\text{SPIKE}}$	3	-	-	$\mu\text{s}$
VDD Low Level	$V_{\text{DDlow}}$	0	-	0.2	V
VDD Rising Slope	$SR_{\text{VDD}}$	10	-	-	V/ms

### 1.3. Electrical Parameters

All parameter values are valid only under the specified operating conditions. All voltages are referenced to Vss.

**Table 1.4 Electrical Parameters**

Note: See important table notes at the end of the table.

Parameter	Symbol	Conditions/Comments	Min	Typ	Max	Unit
<b>Supply</b>						
External Sensor Supply Voltage, ADC Reference Voltage	$V_{\text{DDB}}$	Internally generated	1.60	1.68	1.75	V
Current Consumption	$I_{\text{VDD}}$	Active State, average		1050	1500	$\mu\text{A}$
		Sleep State, idle current, $\leq 85^\circ\text{C}$		20	250	nA
Power Supply Rejection $20 \cdot \log_{10}(V_{\text{DD}}/V_{\text{DDB}})$ (see section 1.4)	$PSR_{\text{VDD}}$	$V_{\text{DD}} = 1.8\text{V}$	17	60	88	dB
		$V_{\text{DD}} = 2\text{V}$	32	65	91	dB
<b>Analog-to-Digital Converter (ADC, A2D)</b>						
Resolution	$r_{\text{ADC}}$		12		18	Bit
ADC Clock Frequency	$f_{\text{ADC}}$	Internal ADC clock	0.9	1	1.1	MHz
Conversion Rate	$f_{\text{S,raw}}$	Conversions per second for single 18-bit external sensor A2D conversion (w/o AZ)			1.1	kHz
		Conversions per second for single 16-bit temperature sensor A2D conversion (w/o AZ)			2.3	kHz

Parameter	Symbol	Conditions/Comments	Min	Typ	Max	Unit
<b>Amplifier</b>						
Gain	G <sub>amp</sub>	64 steps	6.6		216	
Gain Error	G <sub>err</sub>	Referenced to nominal gain	-2.5	-	2.5	%
<b>Sensor Signal Conditioning Performance</b>						
IC Accuracy Error <sup>1)</sup>	Err <sub>A,IC</sub>	Accuracy error for sensor that is ideally linear (in temperature and measurand)			0.01	%FSO
Conversion Rate, 18-Bit SSC	f <sub>s,SSC</sub>	Conversion per second for fully corrected 18-bit measurement		270	300	Hz
<b>Input</b>						
Input Voltage Range	V <sub>INP</sub> , V <sub>INN</sub>	Input voltage range at INP and INN	0.65		1.05	V
External Sensor Bridge Resistance	R <sub>BR</sub>	Full power supply disturbance rejection (PSRR) capabilities	1	10	50	kΩ
		Reduced PSRR, but full functionality	100		999	Ω
<b>Power-Up</b>						
Start-up Time	t <sub>STA1</sub>	V <sub>DD</sub> ramp up to interface communication (see section 3.1)			1	ms
	t <sub>STA2</sub>	V <sub>DD</sub> ramp up to analog operation			2.5	ms
Wake-up Time	t <sub>WUP1</sub>	Sleep to Active State interface communication			0.5	ms
	t <sub>WUP2</sub>	Sleep to Active State analog operation			2	ms
<b>Oscillator</b>						
Internal Oscillator Frequency	f <sub>CLK</sub>		3.6	4	4.4	MHz
<b>Internal Temperature Sensor</b>						
Temperature Resolution		-40°C to +85°C		0.003		K/LSB
<b>Interface and Memory</b>						
SPI Clock Frequency	f <sub>C,SPI</sub>	Maximum capacitance at MISO line: 40pF at V <sub>DD</sub> =1.8V		1	20	MHz
I <sup>2</sup> C™ Clock Frequency	f <sub>C,I2C</sub>				3.4	MHz
Program Time	t <sub>prog</sub>	MTP programming time per 16-bit register		5	16	ms
Endurance	n <sub>MTP</sub>	Number of reprogramming cycles	1000	10000		numeric
Data Retention	t <sub>RET_MTP</sub>	1000h at 125°C	10			a
1) Percentage referred to maximum full-scale output (FSO); e.g. for 18-bit measurements: Err <sub>A,IC</sub> [%FSO] = 100 · MAX{  ADC <sub>meas</sub> - ADC <sub>ideal</sub>   } / 2 <sup>18</sup> .						



1.4. Power Supply Rejection Ratio (PSRR) vs. Frequency

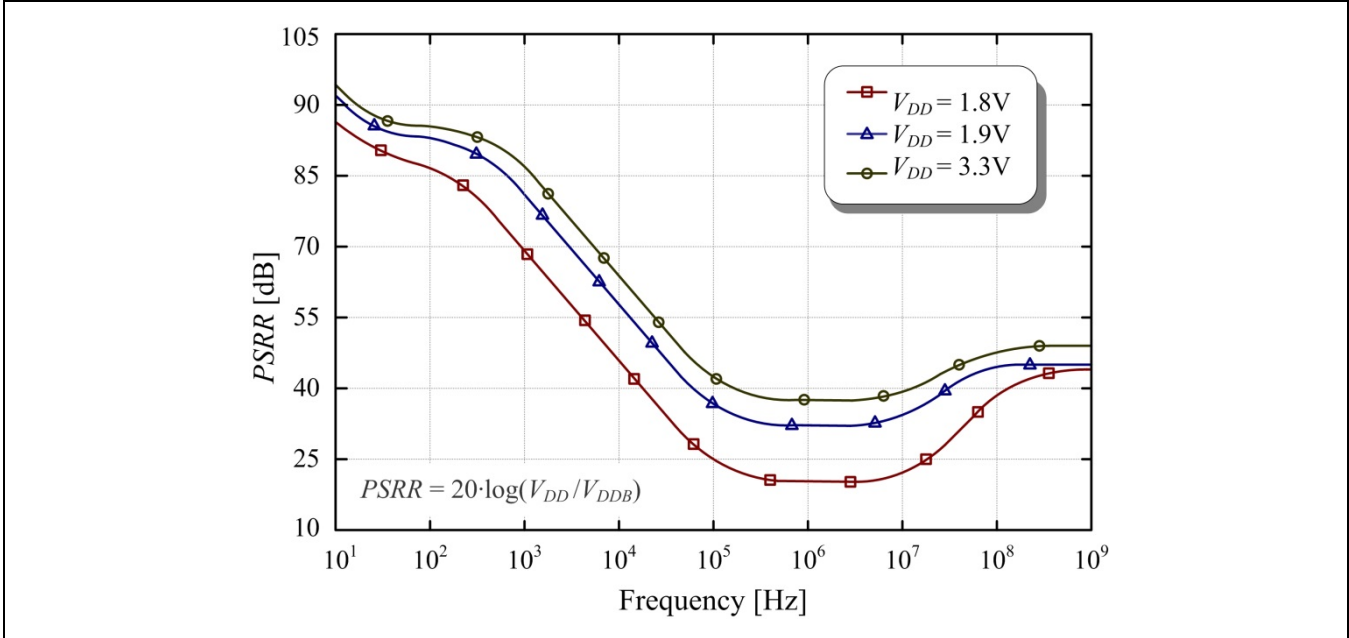

## 2 Circuit Description

### 2.1. Brief Description

The ZSSC3218 provides a highly accurate amplification of bridge sensor signals. The compensation of sensor offset, sensitivity, temperature drift, and non-linearity is accomplished via a 26-bit DSP core running a correction algorithm with calibration coefficients stored in a non-volatile memory. The ZSSC3218 can be configured for a wide range of resistive bridge sensor types and for absolute voltage source sensors. A digital interface (SPI or I<sup>2</sup>C™) enables communication. The ZSSC3218 supports two operational modes: Normal Mode and Command Mode. Normal Mode is the standard operating mode. Typically in Normal Mode, the ZSSC3218 wakes up from a Sleep State (low power), runs a measurement in Active State, and automatically returns to the Sleep State. (See section 3.4 for details on operational modes.)

### 2.2. Signal Flow and Block Diagram

See Figure 2.1 and Figure 2.2 for the ZSSC3218 block diagram for different input sensors. The sensor bridge supply V<sub>DDB</sub> and the power supply for analog circuitry are provided by a voltage regulator, which is optimized for power supply disturbance rejection (PSRR). See section 1.4 for a graph of PSRR versus frequency. To improve noise suppression, the digital blocks are powered by a separate voltage regulator. A power supervision circuit monitors all supply voltages and generates appropriate reset signals for initializing the digital blocks.

The System Control Unit controls the analog circuitry to perform the three measurement types: external sensor, temperature, and offset measurement. The multiplexer selects the signal input to the amplifier, which can be the external signals from the input pins INP and INN or the internal temperature reference sensor signals. A full measurement request will trigger an automatic sequence of all measurement types and all input signals.

**Figure 2.1 ZSSC3218 Functional Block Diagram, Resistive-Bridge Sensor**

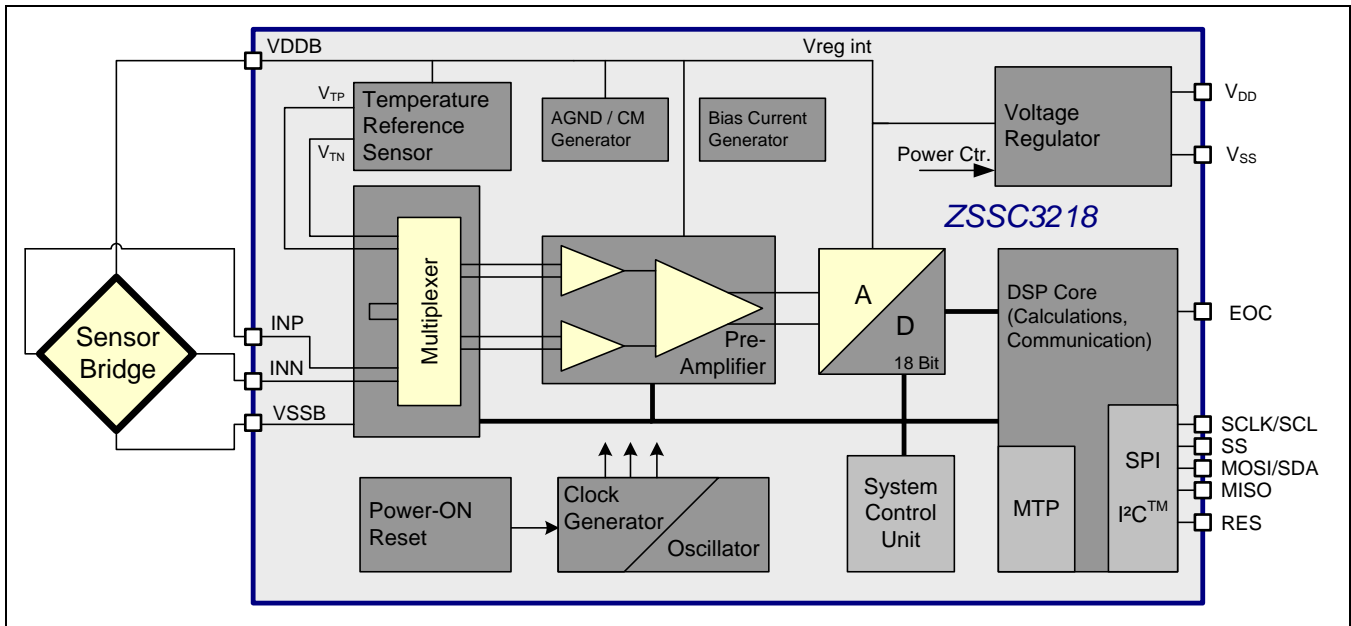
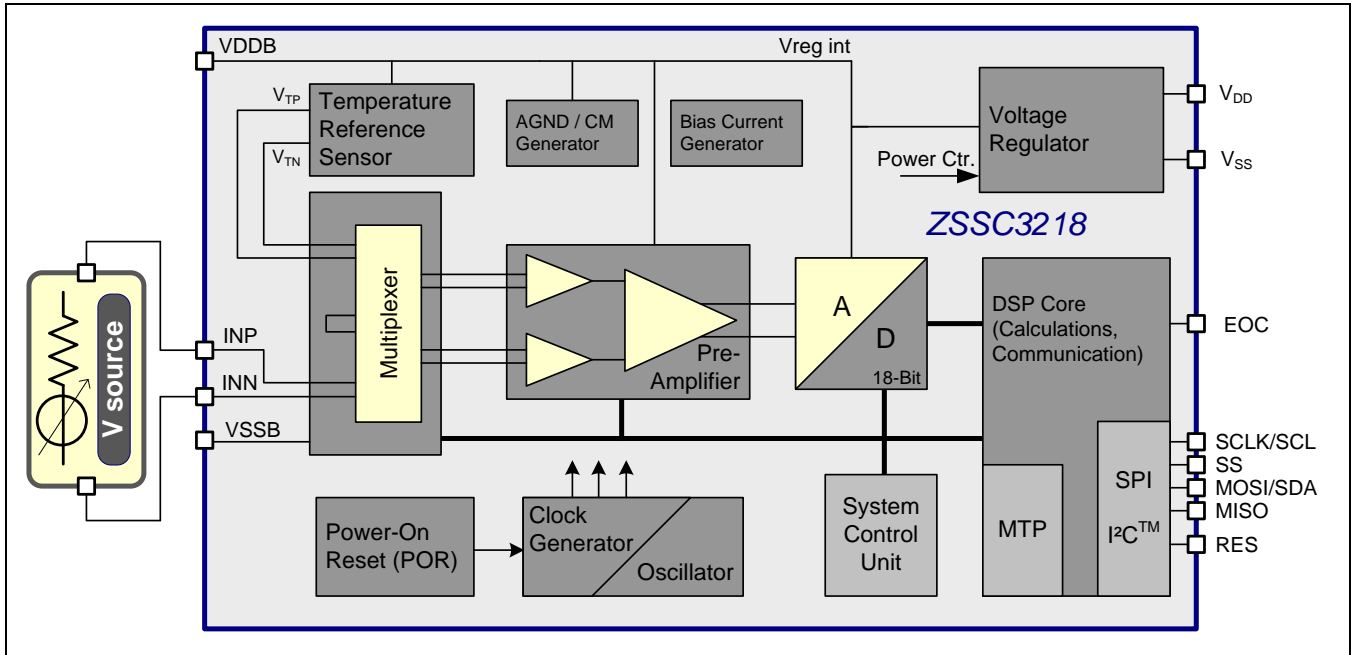

Figure 2.2 ZSSC3218 Functional Block Diagram, Voltage-Source Sensor



The amplifier consists of two stages with programmable gain values.

The ZSSC3218 employs a programmable analog-to-digital converter (ADC) optimized for conversion speed and noise suppression. The programmable resolution from 12 to 18 bits provides flexibility for adapting the conversion characteristics. To improve power supply noise suppression, the ADC uses the bridge supply  $V_{DDB}$  as its reference voltage leading to a ratiometric measurement topology if the external sensor is a bridge-type element.

The remaining IC-internal offset and the sensor element offset, i.e., the overall system offset for the amplifier and ADC, can be canceled by means of an offset and auto-zero measurement, respectively.

The DSP accomplishes the auto-zero, span, and 1<sup>st</sup> and 2<sup>nd</sup> order temperature compensation of the measured external sensor signal. The correction coefficients are stored in the MTP memory.

The ZSSC3218 supports SPI and I<sup>2</sup>C™ interface communication for controlling the ZSSC3218, configuration, and measurement result output.

## 2.3. Analog Front End

### 2.3.1. Amplifier

The amplifier has a fully differential architecture and consists of two stages. The amplification of each stage and the external sensor gain polarity are programmable via settings in the Measurement Configuration Register *SM\_config1* and *SM\_config2* (addresses 12<sub>HEX</sub> and 16<sub>HEX</sub>; see section 3.6.2) in the MTP memory (for details, see section 2.4.2).

The first 6 bits of *SM\_config*<sup>\*</sup> are the programmable gain settings *Gain\_stage1* and *Gain\_stage2*. The options for the programmable gain settings are listed in Table 2.1 and Table 2.2.

**Table 2.1 Amplifier Gain: Stage 1**

<i>Gain_stage1</i>			
<i>SM_config</i> Bit G2	<i>SM_config</i> Bit G1	<i>SM_config</i> Bit G0	Gain <sub>amp1</sub>
0	0	0	6
0	0	1	12
0	1	0	20
0	1	1	30
1	0	0	40
1	0	1	60
1	1	0	80
1	1	1	120

**Table 2.2 Amplifier Gain: Stage 2**

<i>Gain_stage2</i>			
<i>SM_config</i> Bit G5	<i>SM_config</i> Bit G4	<i>SM_config</i> Bit G3	Gain <sub>amp2</sub>
0	0	0	1.1
0	0	1	1.2
0	1	0	1.3
0	1	1	1.4
1	0	0	1.5
1	0	1	1.6
1	1	0	1.7
1	1	1	1.8

If needed, the polarity of the sensor bridge gain can be reversed by setting the *Gain\_polarity* bit, which is bit 6 in the *SM\_config* register (see section 3.6.2). Changing the gain polarity is achieved by inverting the chopper clock. Table 2.3 gives the settings for the *Gain\_polarity* bit. This feature enables applying a sensor to the ZSSC3218 with swapped input signals at INN and INP; e.g., to avoid crossing wires for the final sensor module's assembly.

**Table 2.3 Gain Polarity**

<i>Gain_polarity</i> ( <i>SM_config</i> Bit 6)	Gain	Setting Description
0	+1	No polarity change.
1	-1	Gain polarity is inverted.

<sup>\*</sup> The register name *SM\_config* is used for general register content and effect explanations for both *SM\_config1* and *SM\_config2* as the registers' bit assignments are exactly the same for both registers.

### 2.3.2. Analog-to-Digital Converter

An analog-to-digital converter (ADC) is used to digitize the amplifier signal. To allow optimizing the trade-off between conversion time and resolution, the resolution can be programmed from 12-bit to 18-bit (Adc\_bits, *SM\_config* register; section 3.6.2). The ADC processes differential input signals.

**Table 2.4 ADC Conversion Times for a Single Analog-to-Digital Conversion**

Resolution (Bits)	Conversion Time in $\mu\text{s}$ (typical)
12	140
13	185
14	250
15	335
16	470
17	640
18	890

The ADC can perform an offset shift in order to adapt input signals with offsets to the ADC input range. The shift feature is enabled by setting *SM\_config* register's bit [15] = 1 (*Shift\_method* = 1). The respective analog offset shift can be set up with bits [14:12], *Offset* in *SM\_config*. The offset shift causes the ADC to perform an additional amplification of the ADC's input signal by factor 2. This must be considered for a correct analog sensor setup by means of the pre-amplifier's gain, the ADC offset shift, and the potential ADC gain.

The overall analog amplification  $Gain_{total} = Gain_{amp1} \cdot Gain_{amp2} \cdot Gain_{ADC}$  can be determined for the following potential use cases:

- If no offset shift is selected, i.e., *Shift\_method* = 0 and *Offset* = 000 in *SM\_config*,  

$$Gain_{total} = Gain_{amp1} \cdot Gain_{amp2} \cdot 1$$
- If ADC offset shift is selected, i.e., *Shift\_method* = 1 (*Offset* is arbitrary) in *SM\_config*,  

$$Gain_{total} = Gain_{amp1} \cdot Gain_{amp2} \cdot 2$$

**Table 2.5 ADC Offset Shift**

SM_config Bit 15 (Shift_method)	Offset Shift in ADC				Gain <sub>ADC</sub>	Compensation of Percentage Offset in Input Signal
	Offset: SM_config Bit 14	Offset: SM_config Bit 13	Offset: SM_config Bit 12			
0	0	0	0	1	0%	
1	0	0	0	2	0%	
1	0	0	1	2	6.75%	
1	0	1	0	2	12.50%	
1	0	1	1	2	19.25%	
1	1	0	0	2	25.00%	
1	1	0	1	2	31.75%	
1	1	1	0	2	38.50%	
1	1	1	1	2	43.25%	

**Note:** If no offset shift will be performed and the ADC will not apply the additional gain of factor 2 (leading to  $Gain_{ADC} = 1$ ), then  $Shift\_method = 0$  and  $Offset = 000$  in  $SM\_config$  must be selected. Any other setup with  $Shift\_method = 0$  and  $Offset \neq 000$  leads to erroneous analog setups.

**Table 2.6 Typical Conversion Times vs. Noise Performance with Full Sensor Signal Conditioning for AZSM, SM, AZTM, and TM (Bridge-Type Sensor)**

ADC Resolution: Temperature Sensor	ADC Resolution: External Sensor	Typical Measurement Duration <sup>1)</sup> , MEASURE, (AA <sub>HEX</sub> ) (ms)	Typical 3-Sigma Noise for SSC- Corrected Output <sup>2)</sup> (counts)
16	12	2.2	2.4
16	13	2.3	2.5
16	14	2.4	3.0
16	15	2.6	4.4
16	16	2.8	5.7
16	17	3.2	10.5
16	18	3.7	18.0

1) Measurement duration is defined as the time from the high/low transition at the EOC pin at the beginning of the measurement until the low/high back-transition of the EOC signal at the end of a single measurement in Sleep Mode.

2) Reference noise values normalized to the respective external sensor's ADC resolution, obtained with the following setup: 20kΩ sensor bridge, 25°C, Gain=52, Offset=25%, VDD=1.8V.

### 2.3.3. Selection of Gain and Offset – Sensor System Dimensioning

The optimal gain (and offset) setup for a specific sensor element can be determined by the following steps:

- 1) Collect sensor element's characteristic, statistical data (over temperature, ambient sensor parameter, and over production tolerances):
  - a. Minimum differential output voltage:  $V_{min}$
  - b. Maximum differential output voltage:  $V_{max}$

*Note:* The best possible setup can only be determined if the absolute value of  $V_{max}$  is bigger than the absolute value of  $V_{min}$ . If this is not the case, the gain polarity should be reversed by means of the *Gain\_polarity* bit in the MTP's *SM\_config* register.

- 2) Calculate:
  - a. Common mode level, i.e. differential offset of the sensor output:  $V_{CM} = 0.5 \cdot (V_{max} + V_{min})$
  - b. Relative or percentage offset of the sensor output:  $Offset_{sensor}[\%] = \frac{V_{CM}}{V_{max} - V_{min}} \cdot 100\%$
- 3) Determine which of the two following cases is valid.
  - a. If  $Offset_{sensor}[\%] > 43\%$  then select  $Offset = 111$  (i.e., 43.25%)
  - b. If  $0\% < Offset_{sensor}[\%] \leq 43\%$  then select  $Offset \leq Offset_{sensor}[\%]$  (*Offset* setup value; see Table 2.5)

- 4) The totally required, optimum gain can be determined as

$$Gain_{total,opt} = \frac{1.4V}{V_{max} \cdot \left(1 - \frac{Offset_{sensor}}{100}\right)} \text{ then select nearest gain to } Gain_{total,opt}, \text{ where } Gain_{total} \leq Gain_{total,opt}$$

- 5) The gain setup can be separated into the three factors  $Gain_{amp1}$ ,  $Gain_{amp2}$  (for the 2-stage amplifier) and  $Gain_{ADC}$  (1 for no-shift or 2 for shift operation) according to:  $Gain_{total} = Gain_{amp1} \cdot Gain_{amp2} \cdot Gain_{ADC}$ .
  - a. If no offset shift is performed ( $Shift\_method = 0$  and  $Offset = 000$ ), the amplifier gain is  $Gain_{total}$
  - b. If an offset shift is performed ( $Shift\_method = 1$ ), the amplifier gain is  $0.5 \cdot Gain_{total}$

Figure 2.3 Gain and Offset Setup

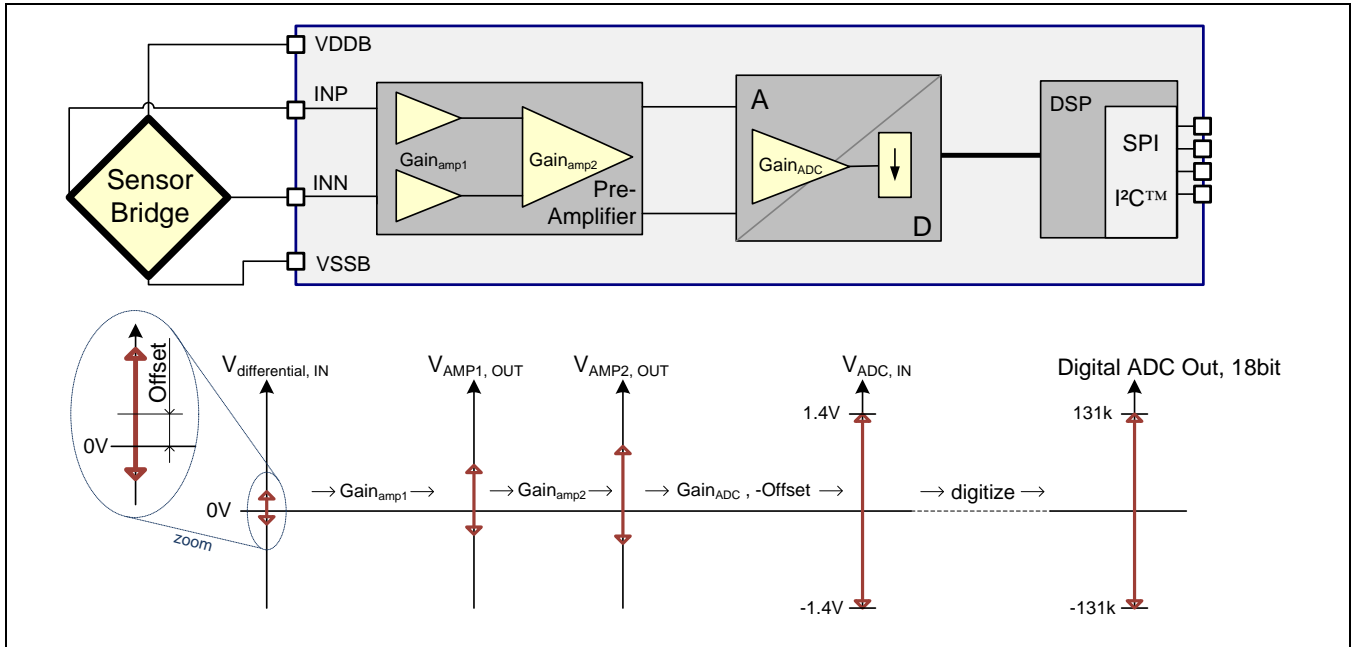

**2.3.4. Temperature Measurement**

The ZSSC3218 provides an internal temperature sensor measurement to allow compensation for temperature effects. See section 1.3 for the temperature sensor resolution. The temperature output signal is a differential voltage that is adapted by the amplifier for the ADC input.

For temperature measurements, the respective settings are defined and programmed in the MTP by IDT.

**2.3.5. External Sensor Supply: Bridge Sensors**

The ZSSC3218 provides dedicated supply pins VDDB and VSSB for resistive bridge-type sensors (bit [11]=0 in *SM\_config*, MTP registers 12<sub>HEX</sub> or 16<sub>HEX</sub>). The ADC reference voltages for the sensor bridge measurement are derived from these internal voltages such that bridge supply disturbances are suppressed. The current drive ability of V<sub>DDB</sub> is limited (see I<sub>V<sub>DDB</sub></sub> in section 1.2).

**2.3.6. External Sensor: Absolute Voltage Source Sensors**

The ZSSC3218 can alternatively process signals from an absolute-voltage source sensor, e.g. a thermopile element. The respective input-type selection can be done with bit[11]=1 in *SM\_config*, MTP registers 12<sub>HEX</sub> or 16<sub>HEX</sub>. The respective sensor element must be connected between the pins INP and INN, whereas INN is internally connected to the ZSSC3218's analog ground (not! being VSSB). VDDB and VSSB should not be connected if an absolute-voltage source sensor is applied. The offset shift should be set to maximum in this case, *Shift\_method* = 1 and *Offset* = 111 in *SM\_config*. The required gain can be determined according to the procedure described in section 2.3.3.



## 2.4. Digital Section

### 2.4.1. Digital Signal Processor (DSP) Core

The “DSP Core” block performs the algorithm for correcting the sensor signal. The required coefficients are stored in the MTP memory.

When the measurement results are available, the “end of conversion” signal is set at the EOC pin if no interrupt-threshold has been set up (bits[8:7]=00 in memory register 02<sub>HEX</sub>). The internal EOC information is valid only if both the measurement and calculation have been completed. Alternatively, the EOC pin can indicate exceeding or underrunning of a certain threshold or leaving of valid-result range as described in section 3.3.

### 2.4.2. MTP Memory

The ZSSC3218’s memory is designed with a real MTP structure. The memory is organized in 16-bit registers that can be re-written multiple (at least 1000) times. The user has access to a 57 x 16-bit storage area for values such as calibration coefficients. The required programming voltage is generated internally in the ZSSC3218. A checksum (generation with command 90<sub>HEX</sub>) is evaluated for integrity-check purposes of the entire memory.

### 2.4.3. Clock Generator

The clock generator provides approximately 4MHz, and 1MHz clock signals as the time base for IC-internal signal processing. The frequency is trimmed during production test.

### 2.4.4. Power Supervision

The power supervision block as a part of the voltage regulator combined with the digital section monitors all power supplies to ensure a defined reset of all digital blocks during power-up or power supply interruptions. “Brown-out” cases at the supply that do not meet the power-on reset (POR) requirements (see Table 1.3), must be resolved with a reset pulse at the RES pin.

### 2.4.5. Interface

The ZSSC3218 can communicate with the user’s communication master or PC via an SPI or I<sup>2</sup>C™ interface †. The interface type is selectable with the very first activity at the interface after power-up or reset, with the first activity being

- a. If the first command is an I<sup>2</sup>C™ command and SS pin has been inactive until receiving this command, the ZSSC3218 enters I<sup>2</sup>C™ mode.
- b. If the first interface action is the SS pin being set to active (HIGH-active or LOW-active depending on SS\_polarity bit[9] in memory interface register 02<sub>HEX</sub>), then the ZSSC3218 enters SPI mode.

During the initiation sequence (after power-up or reset), any potential transition on SS is ignored. Switching to the *SPI mode* is only possible after the power-up sequence. If SS is not connected, the SS pin internal pull-up keeps the ZSSC3218 in I<sup>2</sup>C™ mode.

To also provide interface accessibility in Sleep State (all features inactive except for the digital interface logic), the interface circuitry is directly supplied by VDD.

---

† Functional I<sup>2</sup>C™ interface properties correspond to the NXP I<sup>2</sup>C™ bus specification Rev. 0.3 (June 2009).

## 3 Functional Description

### 3.1. Power Up

Specifications for this section are given in sections 1.2 and 1.3. On power-up, the ZSSC3218 communication interface is able to receive the first command after a time  $t_{STA1}$  from when the VDD supply is within operating specifications. The ZSSC3218 can begin the first measurement after a time of  $t_{STA2}$ , from when the VDD supply is operational. Alternatively, instead of a power-on-reset, a reset and new power-up-sequence respectively can be triggered by an IC-reset signal (high low) at RES pin.

The wake up time from Sleep State to Active State (see section 3.4) after receiving the activating command is defined as  $t_{WUP1}$  and  $t_{WUP2}$ . In Command Mode, subsequent commands can be sent after  $t_{WUP1}$ . The first measurement starts after  $t_{WUP2}$  if a measurement request was sent.

### 3.2. Measurements

Available measurement procedures are

- AZSM: auto-zero (external) sensor measurement
- SM: (external) sensor measurement
- AZTM: auto-zero temperature measurement
- TM: temperature measurement

**AZSM:** The configuration is loaded for measuring the external sensor; i.e., a resistive bridge or an absolute voltage source. The “Multiplexer” block connects the amplifier input to the AGND analog ground reference. An analog-to-digital (A2D) conversion is performed so that the inherent system offset for the respective configuration is converted by the ADC to a digital word with a resolution according to the respective MTP configuration.

**SM:** The configuration is loaded for measuring the external sensor; i.e. a resistive bridge or an absolute voltage source. The “Multiplexer” block connects the amplifier input to the INP and INN pins. An A2D conversion is performed. The result is a digital word with a resolution according to the MTP configuration.

**AZTM:** The configuration for temperature measurements is loaded. The “Multiplexer” block connects the amplifier input to AGND. An analog-to-digital conversion is performed so that the inherent system offset for the temperature configuration is converted by the ADC with a resolution according to the respective MTP configuration.

**TM:** The configuration for temperature measurements is loaded. The “Multiplexer” block connects the amplifier input to the internal temperature sensor. An A2D conversion is performed. The result is a digital word with a resolution according to the MTP configuration.

The typical application’s measurement cycle is a complete SSC measurement (using the commands  $AA_{HEX}$  to  $AF_{HEX}$ ; see section 3.4.1) with AZSM, SM, AZTM, and TM followed by a signal correction calculation.

### 3.3. Interrupt (EOC Pin)

The EOC pin can be programmed to operate either as a pure “measurement busy” and end-of-conversion indicator or as a configurable interrupt indicator. The respective basic operation must be programmed to the INT\_setup bits [8:7] in register 02<sub>HEX</sub> (see Table 3.5).

In addition, one or two 24-bit-quantized thresholds can be programmed (TRSH1 and TRSH2 in memory registers 13<sub>HEX</sub>, 14<sub>HEX</sub>, and 15<sub>HEX</sub>).

The respective thresholds are programmed left-aligned in the memory; i.e., they must be programmed with the threshold’s MSB in the memory register’s MSB, etc. The number of LSB threshold bits that are used is equal to the number of bits for the selected ADC resolution (determined by the Adc\_bits field in registers 12<sub>HEX</sub> and 16<sub>HEX</sub>); unused LSB bits are ignored.

The interrupt functionality is only available for digital values from the SSC-calculation unit (i.e., after sensor signal conditioning); raw values cannot be monitored by the interrupt feature. Figure 3.1 shows the different setup options and the respective response at the EOC pin. The use of the interrupt functionality is recommended for cyclic operation (command AB<sub>HEX</sub> with the respective power-down setup in the *Interface Configuration* memory register 02<sub>HEX</sub>). The EOC level continuously represents the respective SSC-measurement results only during cyclic operation. For single or oversample measurement requests without cyclic operation, the EOC output signal is reset to logical zero at the beginning of each new measurement, even though the interrupt thresholds are considered correctly at the end of each measurement (setting EOC to logical one or zero is dependent on the interrupt setup).

Figure 3.1 Interrupt Functionality

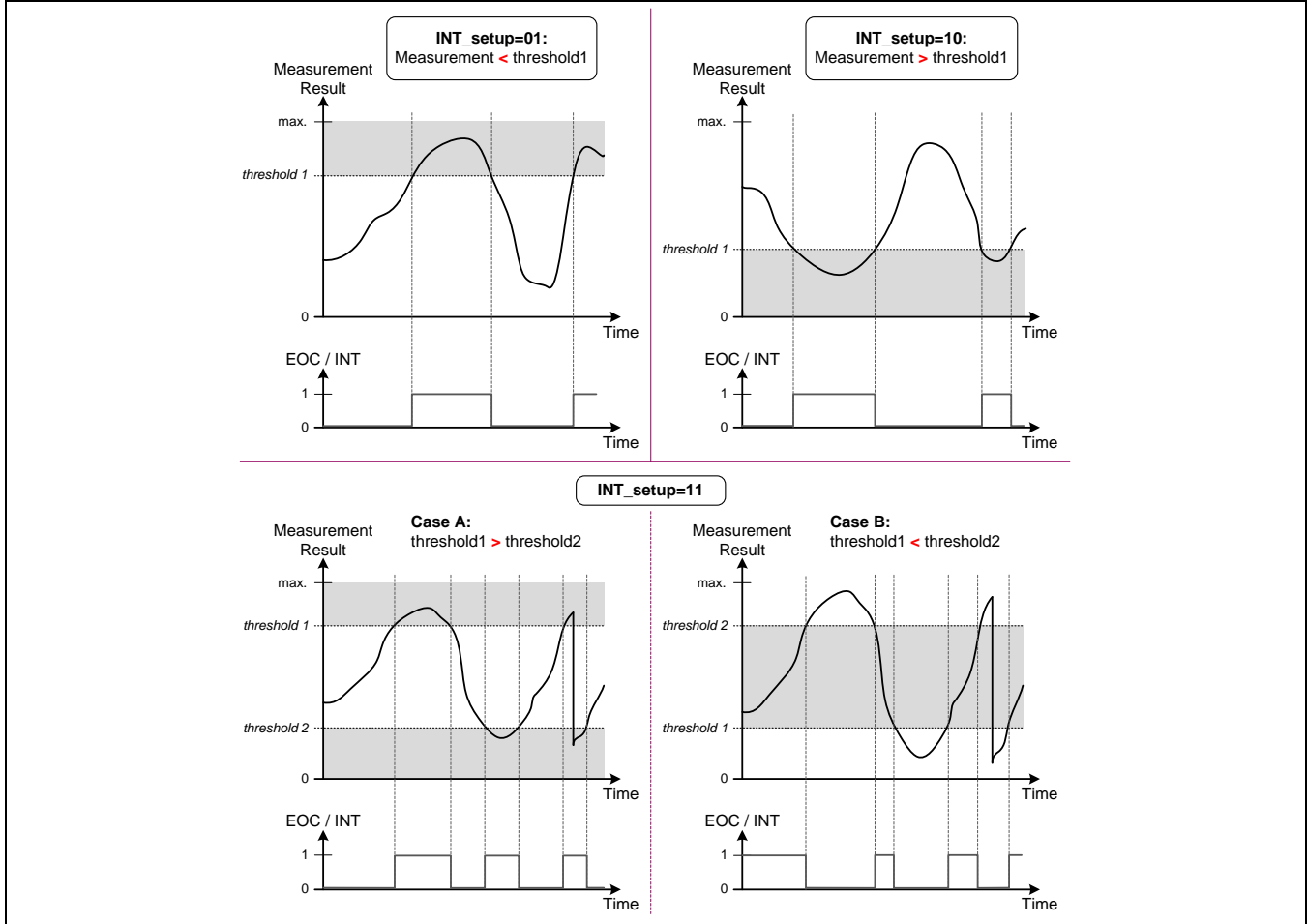

### 3.4. Operational Modes

Figure 3.2 illustrates the ZSSC3218 power-up sequence and subsequent operation depending on the selected interface communication mode (I<sup>2</sup>C™ or SPI) as determined by interface-related first activities after power-up or reset. If the first command after power-up is a valid I<sup>2</sup>C™ command, the interface will function as an I<sup>2</sup>C™ interface until the next power-on-reset. If there is no valid I<sup>2</sup>C™ command, but an active signal at the SS pin is detected as the first valid activity, then the interface will respond as an SPI slave. With either interface, after the voltage regulators are switched on, the ZSSC3218's low-voltage section (LV) is active while the related interface configuration information is read from memory. Then the LV section is switched off, the ZSSC3218 goes into Sleep State, and the interface is ready to receive commands. The interface is always powered by V<sub>DD</sub>, so it is referred to as the high voltage section (HV).

See Table 3.1 for definitions of the commands.

Figure 3.3 shows the ZSSC3218 operation in Normal Mode (with two operation principles: "Sleep" and "Cyclic") and Command Mode, including when the LV and HV sections are active as indicated by the color legend. The Normal Mode automatically returns to Sleep State after executing the requested measurements, or periodically wakes up and conducts another measurement according to the setting for the sleep duration configured by CYC\_period (bits[14:12] in memory register 02<sub>HEX</sub>). In Command Mode, the ZSSC3218 remains active if a dedicated command (Start\_NOM) is sent, which is helpful during calibration. Command Mode can only be entered if Start\_CM is the first command received after POR.

Figure 3.2 Operational Flow Chart: Power Up

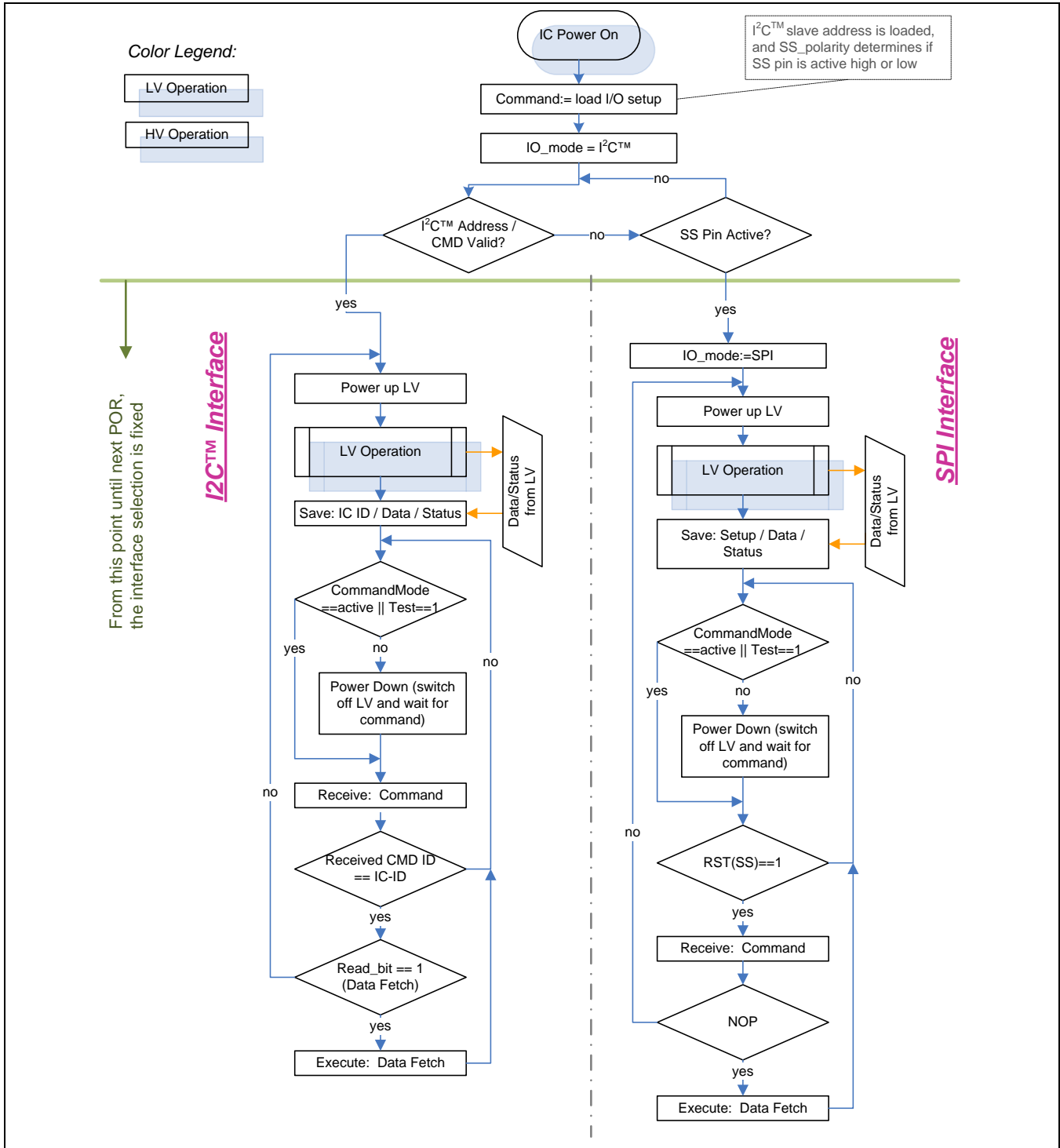
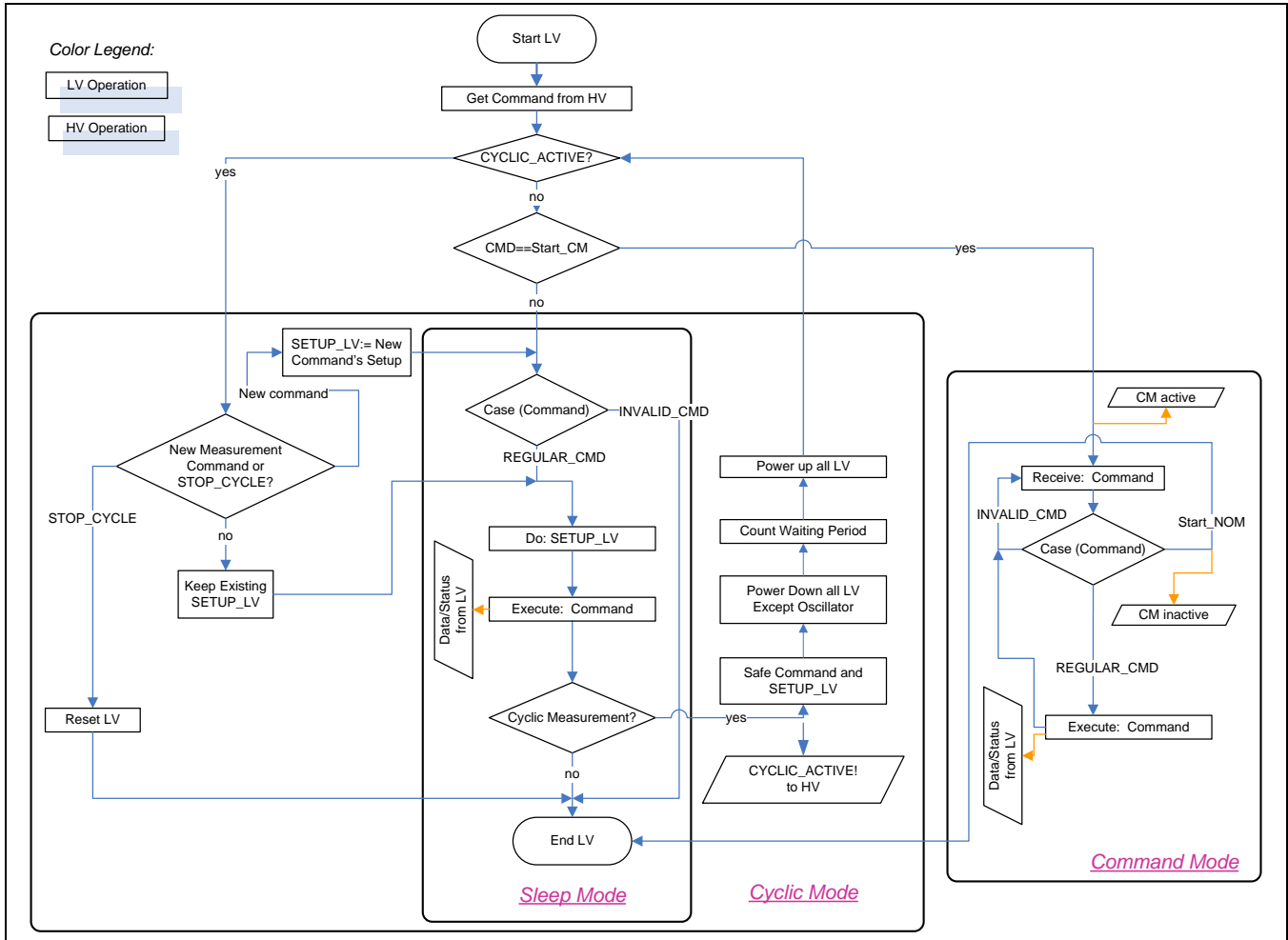

Figure 3.3 Operational Flow Chart: Command Mode and Normal Mode (Sleep and Cyclic)



### 3.4.1. SPI/I<sup>2</sup>C™ Commands

The SPI/I<sup>2</sup>C™ commands supported by the ZSSC3218 are listed in Table 3.1. The command to read an address in the user memory is the same as its address. The command to write to an address in user memory is the address plus 40<sub>HEX</sub>.

There is a IDT-reserved section of memory that can be read but not over-written by the user.

**Table 3.1 SPI/I<sup>2</sup>C™ Commands**

Note: Every return starts with a status byte followed by the data word as described in section 3.5.1.

Command (Byte)	Return	Description	Normal Mode	Command Mode
00 <sub>HEX</sub> to 39 <sub>HEX</sub>	16-bit user data	Read data in the user memory address (00 <sub>HEX</sub> to 39 <sub>HEX</sub> ) matching the command (might not be using all addresses).	Yes	Yes
3A <sub>HEX</sub> to 3F <sub>HEX</sub>	16-bit IDT-reserved memory data	Read data in IDT-reserved memory at address (3A <sub>HEX</sub> to 3F <sub>HEX</sub> ).	Yes	Yes
40 <sub>HEX</sub> to 79 <sub>HEX</sub> followed by data (0000 <sub>HEX</sub> to FFFF <sub>HEX</sub> )	—	Write data to user memory at address specified by command minus 40 <sub>HEX</sub> (addresses 00 <sub>HEX</sub> to 39 <sub>HEX</sub> respectively; might not be using all addresses).	Yes	Yes
90 <sub>HEX</sub>	—	Calculate and write memory checksum (CRC).	Yes	Yes
A0 <sub>HEX</sub> to A7 <sub>HEX</sub> followed by XXXX <sub>HEX</sub> (see Table 3.2)	24-bit formatted raw data	<b>Get_Raw</b> This command can be used to perform a measurement and write the raw ADC data into the output register. The LSB of the command determines how the AFE configuration register is loaded for the Get_Raw measurement (see Table 3.2).	Yes	Yes
A8 <sub>HEX</sub>	—	<b>Start_NOM</b> Exit Command Mode and transition to Normal Mode (Sleep or Cyclic).	No	Yes
A9 <sub>HEX</sub>	—	<b>Start_CM</b> Exit Normal Mode and transition to Command Mode (as very first command after power-up).	Yes	No
AA <sub>HEX</sub>	24-bit formatted fully corrected sensor measurement data + 24-bit corrected temperature data	<b>Measure</b> Trigger full measurement cycle (AZSM, SM, AZTM, and TM, as described in section 3.2) and calculation and storage of data in the output buffer using the configuration from MTP.	Yes	Yes



Command (Byte)	Return	Description	Normal Mode	Command Mode
AB <sub>HEX</sub>	24-bit formatted fully corrected sensor measurement data + 24-bit corrected temperature data	<b>Measure Cyclic</b> This command triggers a continuous full measurement cycle (AZSM, SM, AZTM, and TM; see section 3.2) and calculation and storage of data in the output buffer using the configuration from MTP followed by a pause determined by CYC_period (bits[14:12] in memory register 02 <sub>HEX</sub> ).	Yes	Yes
AC <sub>HEX</sub>	24-bit formatted fully corrected sensor measurement data + 24-bit corrected temperature data	<b>Oversample-2 Measure</b> Mean value generation: 2 full measurements are conducted (as in command AA <sub>HEX</sub> ), the measurements' mean value is calculated, and data is stored in the output buffer using the configuration from MTP; no power down or pause between the 2 measurements.	Yes	Yes
AD <sub>HEX</sub>	24-bit formatted fully corrected sensor measurement data + 24-bit corrected temperature data	<b>Oversample-4 Measure</b> Mean value generation: 4 full measurements (as in command AA <sub>HEX</sub> ) are conducted, the measurements' mean value is calculated, and data is stored in the output buffer using the configuration from MTP; no power down or pause between the 4 measurements.	Yes	Yes
AE <sub>HEX</sub>	24-bit formatted fully corrected sensor measurement data + 24-bit corrected temperature data	<b>Oversample-8 Measure</b> Mean value generation: 8 full measurements (as in command AA <sub>HEX</sub> ) are conducted, the measurements' mean value is calculated, and data is stored in the output buffer using the configuration from MTP; no power down or pause between the 8 measurements.	Yes	Yes
AF <sub>HEX</sub>	24-bit formatted fully corrected sensor measurement data + 24-bit corrected temperature data	<b>Oversample-16 Measure</b> Mean value generation: 16 full measurements (as in command AA <sub>HEX</sub> ) are conducted, the measurements' mean value is calculated, and data is stored in the output buffer using the configuration from MTP; no power down or pause between the 16 measurements.	Yes	Yes
B0 <sub>HEX</sub>	—	<b>Select SM_config1 register</b> (12 <sub>HEX</sub> in memory) For any measurement using the memory contents for the analog front-end and sensor setup, the respective setup is loaded from the SM_config1 register; status bit[1]==0 (default).	Yes	Yes

Command (Byte)	Return	Description	Normal Mode	Command Mode
B1 <sub>HEX</sub>	—	<b>Select SM_config2 register</b> (16 <sub>HEX</sub> in memory) For any measurement using the memory contents for the analog front-end and sensor setup, the respective setup is loaded from the SM_config2 register, status bit[1]==1	Yes	Yes
BF <sub>HEX</sub>	—	<b>STOP_CYC</b> This command causes a power-down halting the update / cyclic measurement operation and causing a transition to Normal-Sleep operation.	Yes	Yes
FX <sub>HEX</sub>	Status followed by last 24-bit data	<b>NOP</b> Only valid for SPI (see sections 3.5.1 and 3.5.2).	Yes	Yes

**Table 3.2 Get\_Raw Commands**

Command	Measurement	AFE Configuration Register
A0 <sub>HEX</sub> followed by 0000 <sub>HEX</sub>	SM – Sensor Measurement	SM_config1 register or SM_config2 register.
A1 <sub>HEX</sub> followed by ssss <sub>HEX</sub>	SM – Sensor Measurement	sss is the user's configuration setting for the measurement provided via the interface. The format and purpose of configuration bits must be according to the definitions for SM_config (see Table 3.5).
A2 <sub>HEX</sub> followed by 0000 <sub>HEX</sub>	SM-AZSM – Auto-Zero Corrected Sensor Measurement <sup>1)</sup>	SM_config
A3 <sub>HEX</sub> followed by ssss <sub>HEX</sub>	SM-AZSM – Auto-Zero Corrected Sensor Measurement <sup>2)</sup>	sss is the user's configuration setting for the measurement provided via the interface. The format and purpose of configuration bits must be according to the definitions for SM_config.
A4 <sub>HEX</sub> followed by 0000 <sub>HEX</sub>	TM – Temperature Measurement	IDT-defined register
A5 <sub>HEX</sub> followed by ssss <sub>HEX</sub>	TM – Temperature Measurement	sss is the user's configuration setting for the measurement provided via the interface. The format and purpose of configuration bits must be according to the definitions for SM_config and valid for temperature measurement in this case (bits [15:12] will be ignored).
A6 <sub>HEX</sub> followed by 0000 <sub>HEX</sub>	TM-AZTM – Auto-Zero Corrected Temperature Measurement <sup>1)</sup>	IDT-defined register
A7 <sub>HEX</sub> followed by ssss <sub>HEX</sub>	TM-AZTM – Auto-Zero Corrected Temperature Measurement <sup>2)</sup>	sss is the user's configuration setting for the measurement provided via the interface. The format and purpose of these configuration bits must be according to the definitions for SM_config and valid for temperature measurement in this case (bits [15:12] will be ignored).
<p>1) Recommended for raw data collection during calibration coefficient determination using the measurement setups pre-programmed in MTP.</p> <p>2) Recommended for raw data collection during calibration coefficient determination using un-programmed (not in MTP), external measurement setups; e.g., for evaluation purposes.</p>		

### 3.5. Communication Interface

#### 3.5.1. Common Functionality

Commands are handled by the command interpreter in the LV section. Commands that need additional data are not treated differently than other commands because the HV interface is able to buffer the command and all the data that belongs to the command and the command interpreter is activated as soon as a command byte is received.

Every response starts with a status byte followed by the data word. The data word depends on the previous command. It is possible to read the same data more than once if the read request is repeated (I<sup>2</sup>C™) or a NOP command is sent (SPI). If the next command is not a read request (I<sup>2</sup>C™) or a NOP (SPI), it invalidates any previous data.

The ZSSC3218 supports the parallel setup of two amplifier-ADC-configurations using *SM\_config1* and *SM\_config2*. Switching between the two setups can be done with the commands B0<sub>HEX</sub> and B1<sub>HEX</sub>. Note that the respective activation command must always be sent prior to the measurement request.

The status byte contains the following bits in the sequence shown in Table 3.3:

- Power indication (bit 6): 1 if the device is powered (V<sub>DDB</sub> on); 0 if not powered. This is needed for the SPI Mode where the master reads all zeroes if the device is not powered or in power-on reset (POR).
- Busy indication (bit 5): 1 if the device is busy, which indicates that the data for the last command is not available yet. No new commands are processed if the device is busy.  
*Note:* The device is always busy if cyclic measurement operation has been set up and started.
- Currently active ZSSC3218 mode (bits [4:3]): 00 = Normal Mode; 01 = Command Mode; 1X = IDT reserved.
- Memory integrity/error flag (bit 2): 0 if integrity test passed; 1 if test failed. This bit indicates whether the checksum-based integrity check passed or failed. The memory error status bit is calculated only during the power-up sequence, so a newly written CRC will only be used for memory verification and status update after a subsequent ZSSC3218 power-on reset (POR) or reset by means of the RES pin.
- Config Setup (bit 1): This bit indicates which *SM\_config* register is being used for the active configuration: *SM\_config1* (12<sub>HEX</sub>) or *SM\_config2* (16<sub>HEX</sub>). The two alternate configuration setups allow for two different configurations of the external sensor channel in order to support up to two application scenarios with the use of only one sensor-ZSSC3218 pair. This bit is 0 if *SM\_config1* was selected (default). This bit is 1 if *SM\_config2* was selected.
- ALU saturation (bit 0): If the last command was a measurement request, this bit is 0 if any intermediate value and the final SSC result are in a valid range and no SSC-calculation internal saturation occurred in the arithmetic logic unit (ALU). If the last command was a measurement request, this bit is 1 if an SSC-calculation internal saturation occurred. This bit is also 0 for any non-measurement command.

**Table 3.3 General Status Byte**

Bit	7	6	5	4	3	2	1	0
Meaning	0	Powered?	Busy?	Mode		Memory error?	Config Setup	ALU Saturation

**Table 3.4 Mode Status**

Status[4:3]	Mode
00	Normal Mode (sleep and cyclic operations)
01	Command Mode
10	IDT reserved
11	IDT reserved

Further status information can be provided by the EOC pin. The EOC pin is set high when a measurement and calculation have been completed (if no interrupt threshold is used, i.e. INT\_setup==00<sub>BIN</sub>; see section 3.3).

**3.5.2. SPI**

The SPI Mode is available if the very first interface activity after ZSSC3218 power-up is an active signal at the SS pin. The polarity and phase of the SPI clock are programmable via the CKP\_CKE setting in bits [11:10] in address 02<sub>HEX</sub> as described in Table 3.5. CKP\_CKE is two bits: CPHA (bit 10), which selects which edge of SCLK latches data, and CPOL (bit 11), which indicates whether SCLK is high or low when it is idle. The polarity of the SS signal and pin are programmable via the SS\_polarity setting (bit 9). The different combinations of polarity and phase are illustrated in the figures below.

**Figure 3.4 SPI Configuration CPHA=0**

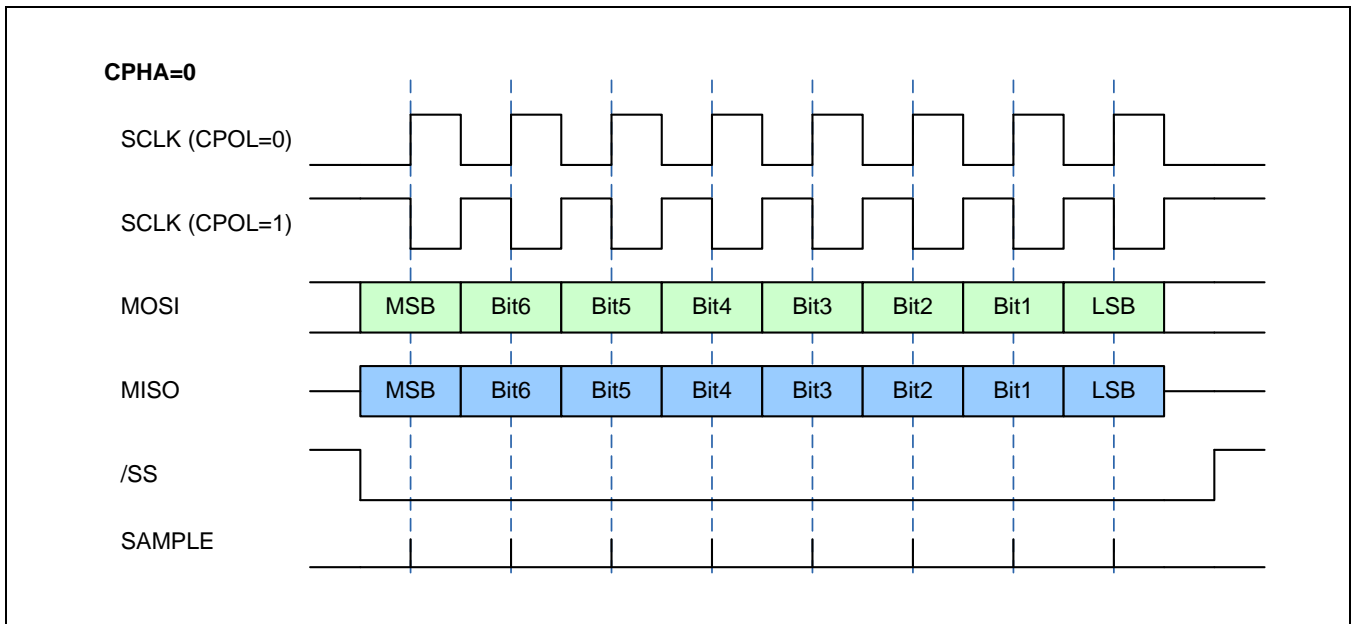

**Figure 3.5 SPI Configuration CPHA=1**

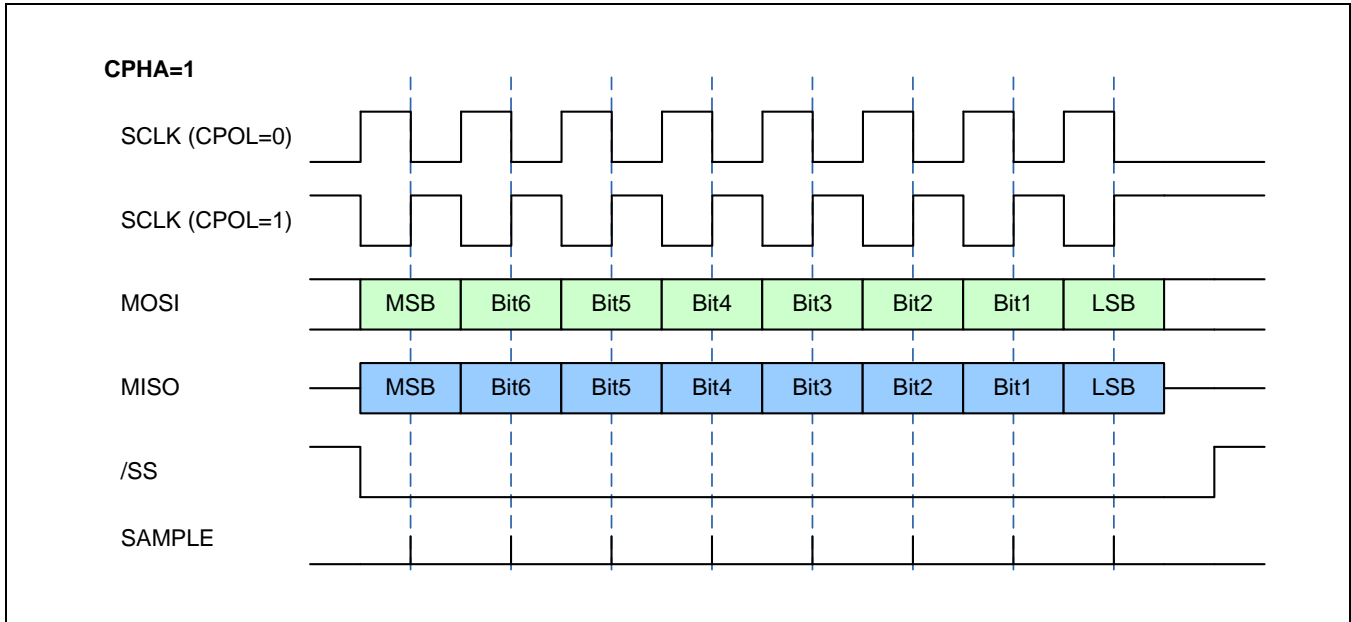

In SPI mode, each command except NOP is started as shown in Figure 3.6. After the execution of a command (busy = 0), the expected data can be read as illustrated in Figure 3.7 or if no data are returned by the command, the next command can be sent. The status can be read at any time with the NOP command (see Figure 3.8).

**Figure 3.6 SPI Command Request**

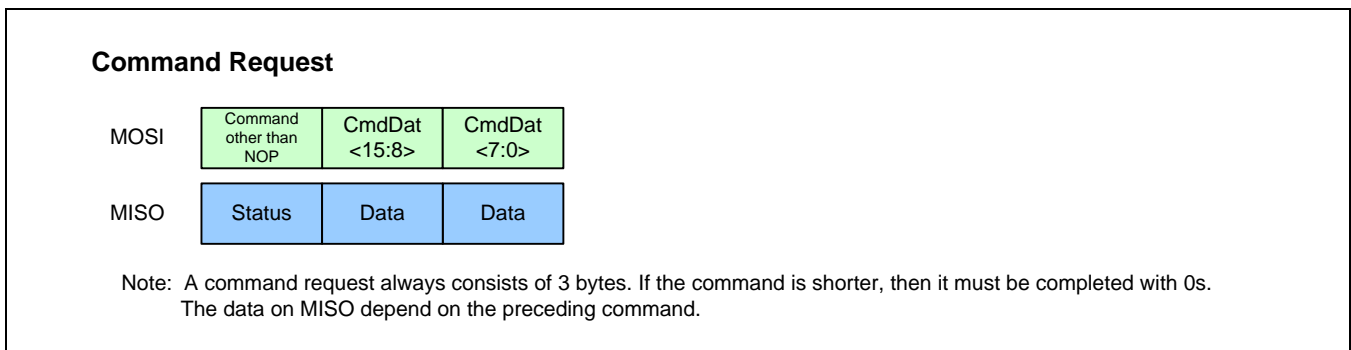

Figure 3.7 SPI Read Status

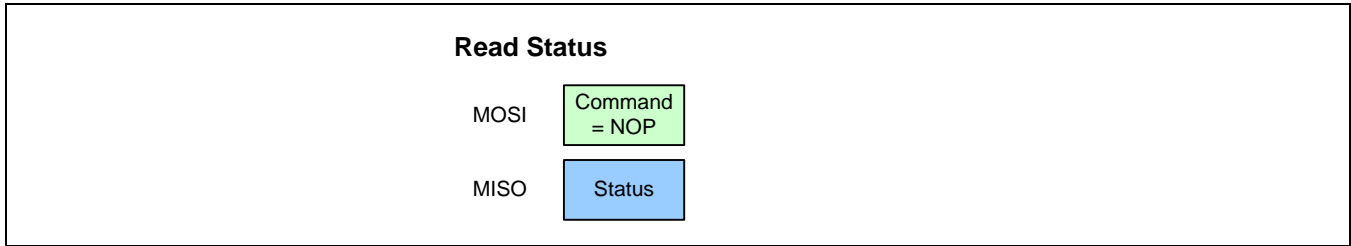
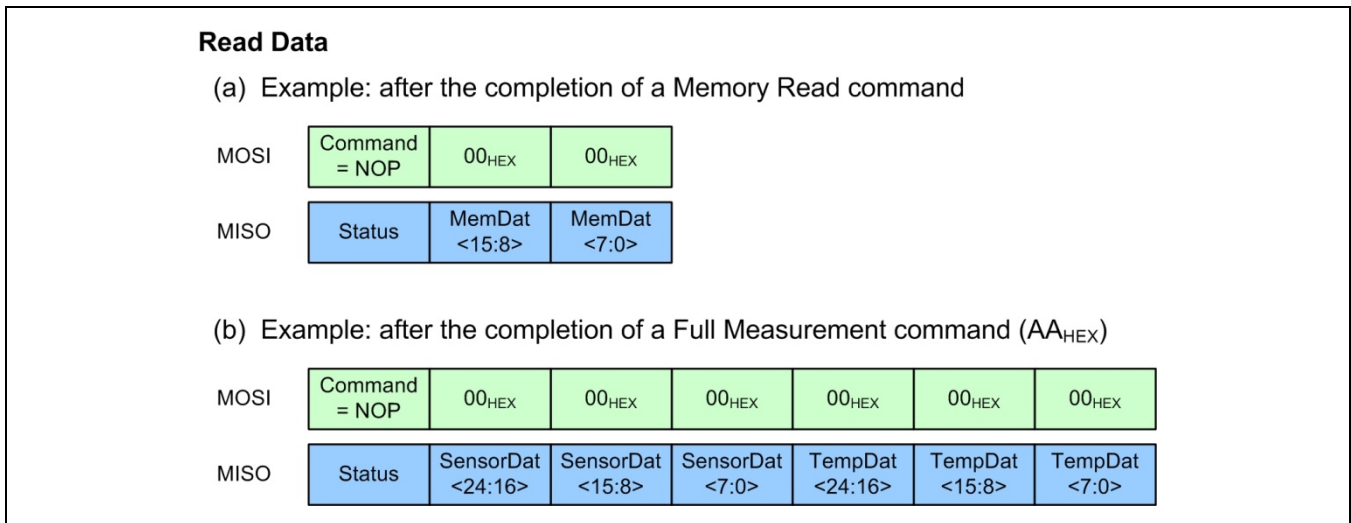

Figure 3.8 SPI Read Data



### 3.5.3. I<sup>2</sup>C™

I<sup>2</sup>C™ Mode will be selected if the very first interface activity after ZSSC3218 power-up is an I<sup>2</sup>C™ command. In I<sup>2</sup>C™ Mode, each command is started as shown in Figure 3.8. Only the number of bytes that are needed for the command must be sent. An exception is the HS-mode where 3 bytes must always be sent as in SPI Mode. After the execution of a command (busy = 0), the expected data can be read as illustrated in Figure 3.11 or if no data are returned by the command, the next command can be sent. The status can be read at any time as described in Figure 3.10.

Figure 3.9 I<sup>2</sup>C™ Command Request

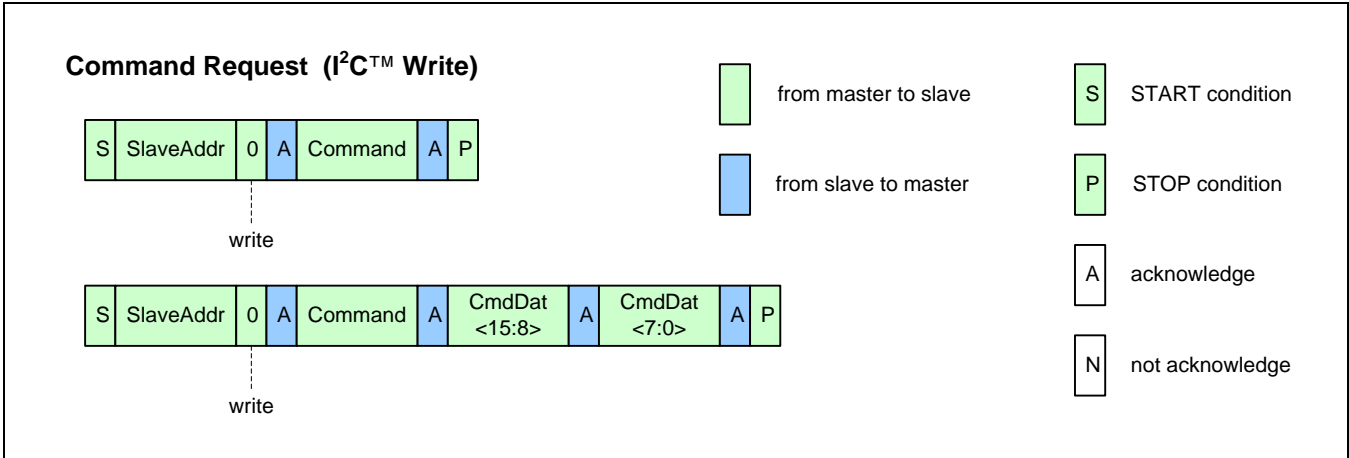

Figure 3.10 I<sup>2</sup>C™ Read Status

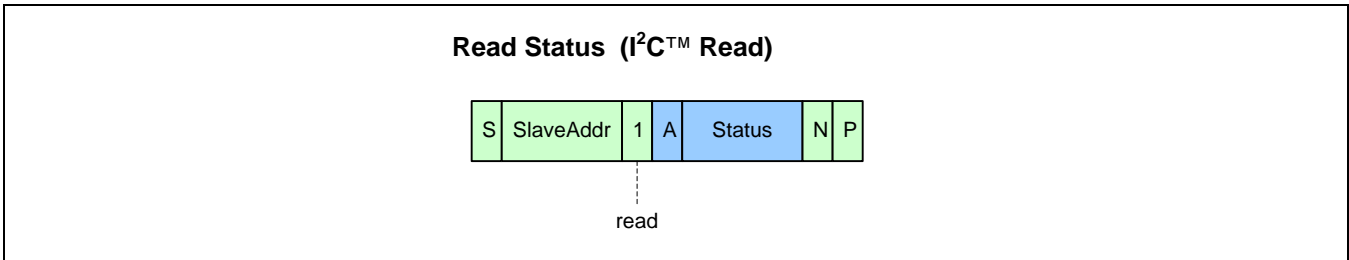
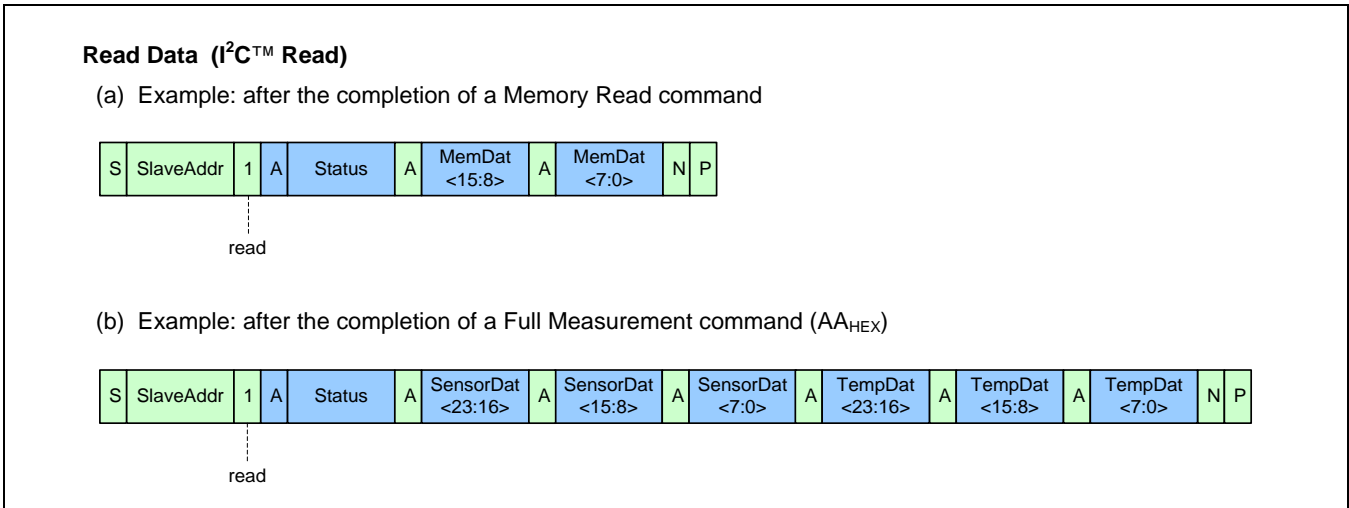

Figure 3.11 I<sup>2</sup>C™ Read Data



All mandatory I<sup>2</sup>C™-bus protocol features are implemented. Optional features such as clock stretching, 10-bit slave address, etc., are not supported by the ZSSC3218's interface.

In I<sup>2</sup>C-High-Speed Mode, a command consists of a fixed length of three bytes.

### **3.6. Multiple Time Programmable (MTP) Memory**

In the ZSSC3218, the memory is organized in 16-bit wide registers and can be programmed multiple times (ca. 1000). There are 57 x 16-bit registers available for customer use. Each register can be re-programmed. Basically, there are two MTP content sectors:

- Customer Use: accessible by means of regular write operations: 40<sub>HEX</sub> to 79<sub>HEX</sub>. It contains the customer ID, interface setup data, measurement setup information, calibration coefficients, etc.
- IDT Use: only accessible for write operations by IDT. The IDT sector contains specific trim information and is programmed during manufacturing test by IDT.

#### **3.6.1. Programming Memory**

Programming memory is possible with any specified supply voltage level at VDD. The MTP programming voltage itself is generated by means of an integrated charge pump, generating an internal memory programming voltage; no additional, external voltage, other than VDD (as specified) is needed. A single 16-bit register write will be completed within 16ms after the respective programming command has been sent. After the memory is programmed, it must be read again to verify the validity of the memory contents.



### 3.6.2. Memory Contents

**Table 3.5 MTP Memory Content Assignments**

MTP Address	Word / Bit Range	Default Setting	Description	Notes / Explanations
00 <sub>HEX</sub>	15:0	0000 <sub>HEX</sub>	Cust_ID0	Customer ID byte 0 (combines with memory word 01 <sub>HEX</sub> to form customer ID).
01 <sub>HEX</sub>	15:0	0000 <sub>HEX</sub>	Cust_ID1	Customer ID byte 1 (combines with memory word 00 <sub>HEX</sub> to form customer ID).
<b>Interface Configuration</b>				
02 <sub>HEX</sub>	6:0	000 0000 <sub>BIN</sub>	Slave_Addr	I <sup>2</sup> C™ slave address; valid range: 00 <sub>HEX</sub> to 7F <sub>HEX</sub> (default: 00 <sub>HEX</sub> ). Note: address codes 04 <sub>HEX</sub> to 07 <sub>HEX</sub> are reserved for entering the I <sup>2</sup> C™ High Speed Mode.
	8:7	00 <sub>BIN</sub>	INT_setup	Interrupt configuration, EOC pin functionality: 00 End-of-conversion signal 01 0-1 transition if threshold1 (TRSH1) is exceeded and 1-0 transition if threshold1 is underrun again 10 0-1 transition if threshold1 is underrun and 1-0 transition if threshold1 is exceeded again 11 EOC is determined by threshold settings (see section 3.3): If (TRSH1 > TRSH2) then EOC/INT (interrupt level) = 0 if (TRSH1 > MEAS ≥ TRSH2) where MEAS is the conditioned measurement result. Otherwise EOC/INT=1. If (TRSH1 ≤ TRSH2) then EOC = 1 if (TRSH1 ≤ MEAS < TRSH2). Otherwise EOC = 0.
	9	0 <sub>BIN</sub>	SS_polarity	Determines the polarity of the Slave Select pin (SS) for SPI operation: 0 ⇔ Slave Select is active low (SPI and ZSSC3218 are active if SS==0) 1 ⇔ Slave Select is active high (SPI and ZSSC3218 are active if SS==1)

MTP Address	Word / Bit Range	Default Setting	Description	Notes / Explanations
	11:10	00 <sub>BIN</sub>	CKP_CKE	Clock polarity and clock-edge select—determines polarity and phase of SPI interface clock with the following modes: 00 ⇔ SCLK is low in idle state, data latch with rising edge and data output with falling edge 01 ⇔ SCLK is low in idle state, data latch with falling edge and data output with rising edge 10 ⇔ SCLK is high in idle state, data latch with falling edge and data output with rising edge 11 ⇔ SCLK is high in idle state, data latch with rising edge and data output with falling edge
	14:12	000 <sub>BIN</sub>	CYC_period	Update period (ZSSC3218 sleep time, except oscillator) in cyclic operation: 000 ⇔ not assigned 001 ⇔ 125ms 010 ⇔ 250ms 011 ⇔ 500ms 100 ⇔ 1000ms 101 ⇔ 2000ms 110 ⇔ 4000ms 111 ⇔ not assigned
	15	0 <sub>BIN</sub>	SOT_curve	Type/shape of second-order curve correction for the sensor signal. 0 ⇔ parabolic curve 1 ⇔ s-shaped curve

MTP Address	Word / Bit Range	Default Setting	Description	Notes / Explanations
<b>Signal Conditioning Parameters</b>				
03 <sub>HEX</sub>	15:0	0000 <sub>HEX</sub>	Offset_S[15:0]	Bits [15:0] of the 24-bit-wide sensor offset correction coefficient Offset_S. (The MSBs of this coefficient including sign are Offset_S[23:16], which is bits [15:8] in 0D <sub>HEX</sub> .)
04 <sub>HEX</sub>	15:0	0000 <sub>HEX</sub>	Gain_S[15:0]	Bits [15:0] of the 24-bit-wide value of the sensor gain coefficient Gain_S. (The MSBs of this coefficient including sign are Gain_S[23:16], which is bits [7:0] in 0D <sub>HEX</sub> .)
05 <sub>HEX</sub>	15:0	0000 <sub>HEX</sub>	Tcg[15:0]	Bits [15:0] of the 24-bit-wide coefficient Tcg for the temperature correction of the sensor gain. (The MSBs of this coefficient including sign are Tcg[23:16], which is bits [15:8] in 0E <sub>HEX</sub> .)
06 <sub>HEX</sub>	15:0	0000 <sub>HEX</sub>	Tco[15:0]	Bits [15:0] of the 24-bit-wide coefficient Tco for temperature correction of the sensor offset. (The MSBs of this coefficient including sign are Tco[23:16], which is bits [7:0] in 0E <sub>HEX</sub> .)
07 <sub>HEX</sub>	15:0	0000 <sub>HEX</sub>	SOT_tco[15:0]	Bits [15:0] of the 24-bit-wide 2 <sup>nd</sup> order term SOT_tco applied to Tco. (The MSBs of this term including sign are SOT_tco[23:16], which is bits[15:8] in 0F <sub>HEX</sub> .)
08 <sub>HEX</sub>	15:0	0000 <sub>HEX</sub>	SOT_tcg[15:0]	Bits [15:0] of the 24-bit-wide 2 <sup>nd</sup> order term SOT_tcg applied to Tcg. (The MSBs of this term including sign are SOT_tcg[23:16], which is bits[7:0] in 0F <sub>HEX</sub> .)
09 <sub>HEX</sub>	15:0	0000 <sub>HEX</sub>	SOT_sens[15:0]	Bits [15:0] of the 24-bit-wide 2 <sup>nd</sup> order term SOT_sens applied to the sensor readout. (The MSBs of this term including sign are SOT_sens[23:16], which is bits[15:8] in 10 <sub>HEX</sub> .)
0A <sub>HEX</sub>	15:0	0000 <sub>HEX</sub>	Offset_T[15:0]	Bits [15:0] of the 24-bit-wide temperature offset correction coefficient Offset_T. (The MSBs of this coefficient including sign are Offset_T[23:16], which is bits[7:0] in 10 <sub>HEX</sub> .)
0B <sub>HEX</sub>	15:0	0000 <sub>HEX</sub>	Gain_T[15:0]	Bits [15:0] of the 24-bit-wide absolute value of the temperature gain coefficient Gain_T. (The MSBs of this coefficient including sign are Gain_T[23:16], which is bits[15:8] in 11 <sub>HEX</sub> .)
0C <sub>HEX</sub>	15:0	0000 <sub>HEX</sub>	SOT_T[15:0]	Bits [15:0] of the 24-bit-wide 2 <sup>nd</sup> -order term SOT_T applied to the temperature reading. (The MSBs of this coefficient including sign are SOT_T[23:16], which is bit[7:0] in 11 <sub>HEX</sub> .)

MTP Address	Word / Bit Range	Default Setting	Description	Notes / Explanations
0D <sub>HEX</sub>	7:0	00 <sub>HEX</sub>	Gain_S[23:16]	Bits [23:16] including sign for the 24-bit-wide sensor gain correction coefficient Gain_S. (The LSBs of this coefficient are Gain_S[15:0] in register 04 <sub>HEX</sub> .)
	15:8	00 <sub>HEX</sub>	Offset_S[23:16]	Bits [23:16] including sign for the 24-bit-wide sensor offset correction coefficient Offset_S. (The LSBs are Offset_S[15:0] in register 03 <sub>HEX</sub> .)
0E <sub>HEX</sub>	7:0	00 <sub>HEX</sub>	Tco[23:16]	Bits [23:16] including sign for the 24-bit-wide coefficient Tco for temperature correction for the sensor offset. (The LSBs are Tco[15:0] in register 06 <sub>HEX</sub> .)
	15:8	00 <sub>HEX</sub>	Tcg[23:16]	Bits [23:16] including sign for the 24-bit-wide coefficient Tcg for the temperature correction of the sensor gain. (The LSBs are Tcg[15:0] in register 05 <sub>HEX</sub> .)
0F <sub>HEX</sub>	7:0	00 <sub>HEX</sub>	SOT_tcg[23:16]	Bits [23:16] including sign for the 24-bit-wide 2 <sup>nd</sup> order term SOT_tcg applied to Tcg. (The LSBs are SOT_tcg[15:0] in register 08 <sub>HEX</sub> .)
	15:8	00 <sub>HEX</sub>	SOT_tco[23:16]	Bits [23:16] including sign for the 24-bit-wide 2 <sup>nd</sup> order term SOT_tco applied to Tco. (The LSBs are SOT_tco[15:0] in register 07 <sub>HEX</sub> .)
10 <sub>HEX</sub>	7:0	00 <sub>HEX</sub>	Offset_T[23:16]	Bits [23:16] including sign for the 24-bit-wide temperature offset correction coefficient Offset_T. (The LSBs are Offset_T[15:0] in register 0A <sub>HEX</sub> .)
	15:8	00 <sub>HEX</sub>	SOT_sens[23:16]	Bits [23:16] including sign for the 24-bit-wide 2 <sup>nd</sup> order term SOT_sens applied to the sensor readout. (The LSBs are SOT_sens[15:0] in register 09 <sub>HEX</sub> .)
11 <sub>HEX</sub>	7:0	00 <sub>HEX</sub>	SOT_T[23:16]	Bits [23:16] including sign for the 24-bit-wide 2 <sup>nd</sup> -order term SOT_T applied to the temperature reading. (The LSBs are SOT_T[15:0] in register 0C <sub>HEX</sub> .)
	15:8	00 <sub>HEX</sub>	Gain_T[23:16]	Bits [23:16] including sign for the 24-bit-wide absolute value of the temperature gain coefficient Gain_T. (The LSBs are Gain_T[15:0] in register 0B <sub>HEX</sub> .)

MTP Address	Word / Bit Range	Default Setting	Description	Notes / Explanations
<b>Measurement Configuration Register 1 (SM_config1)</b>				
12 <sub>HEX</sub>	2:0	000 <sub>BIN</sub>	Gain_stage1	Gain setting for the 1 <sup>st</sup> PREAMP stage with Gain_stage1 ⇔ Gain <sub>amp1</sub> : 000 ⇔ 6 001 ⇔ 12 010 ⇔ 20 011 ⇔ 30 100 ⇔ 40 101 ⇔ 60 110 ⇔ 80 111 ⇔ 120 (Might affect noise and accuracy specifications depending on sensor setup)
	5:3	000 <sub>BIN</sub>	Gain_stage2	Gain setting for the 2 <sup>nd</sup> PREAMP stage with Gain_stage2 ⇔ Gain <sub>amp2</sub> : 000 ⇔ 1.1 001 ⇔ 1.2 010 ⇔ 1.3 011 ⇔ 1.4 100 ⇔ 1.5 101 ⇔ 1.6 110 ⇔ 1.7 111 ⇔ 1.8
	6	0 <sub>BIN</sub>	Gain_polarity	Set up the polarity of the sensor bridge's gain (inverting of the chopper) with 0 ⇔ positive (no polarity change) 1 ⇔ negative (180° polarity change)
	10:7	0000 <sub>BIN</sub>	Adc_bits	Absolute number of bits for the ADC conversion ADC_bits: 0000 ⇔ 12-bit 0001 ⇔ 13-bit 0010 ⇔ 14-bit 0011 ⇔ 15-bit 0100 ⇔ 16-bit 0101 ⇔ 17-bit 0110 ⇔ 18-bit 0111 to 1111 ⇔ not assigned
	11	0 <sub>BIN</sub>	AbsV_enable	Enable bit for thermopile input selection (INN connected to AGND, INP connected to absolute voltage source) with AbsV_enable: 0 ⇔ absolute voltage input disabled (default) 1 ⇔ absolute voltage input enabled (e.g. for a thermopile)

MTP Address	Word / Bit Range	Default Setting	Description	Notes / Explanations
	14:12	000 <sub>BIN</sub>	Offset	Differential signal's offset shift in the ADC; compensation of signal offset by x% of input signal: 000 ⇔ no offset compensation 001 ⇔ 6.75% offset 010 ⇔ 12.5% offset 011 ⇔ 19.25% offset 100 ⇔ 25% offset 101 ⇔ 31.75% offset 110 ⇔ 38.5% offset 111 ⇔ 43.25% offset  Note: Bit 15 below must be set to 1 to enable the offset shift.
	15	0 <sub>BIN</sub>	Shift_method	Offset shift method switch: 0 ⇔ No offset shift. Offset (bits [14:12] in 12 <sub>HEX</sub> ) must be set to 000 <sub>BIN</sub> ; $Gain_{ADC} = 1$ 1 ⇔ Offset shift ADC; $Gain_{ADC} = 2$
13 <sub>HEX</sub>	15:0	0000 <sub>HEX</sub>	TRSH1[15:0]	Bits [15:0] of the 24-bit-wide interrupt threshold1, TRSH1. (The MSB bits for this threshold are TRSH1[23:16], which is bits [7:0] of register 15 <sub>HEX</sub> .)
14 <sub>HEX</sub>	15:0	0000 <sub>HEX</sub>	TRSH2[15:0]	Bits [15:0] of the 24-bit-wide interrupt threshold2, TRSH2. (The MSB bits for this threshold are TRSH2[23:16], which is bits [15:8] of register 15 <sub>HEX</sub> .)
15 <sub>HEX</sub>	7:0	00 <sub>HEX</sub>	TRSH1[23:16]	Bits [23:16] of the 24-bit-wide interrupt threshold1, TRSH1. (The LSB bits for this threshold are TRSH1[15:0], which is bits [15:0] of register 13 <sub>HEX</sub> .)
	15:8	00 <sub>HEX</sub>	TRSH2[23:16]	Bits [23:16] of the 24-bit-wide interrupt threshold2, TRSH2. (The LSB bits for this threshold are TRSH2[15:0], which is bits [15:0] of register 14 <sub>HEX</sub> .)
<b>Measurement Configuration Register 2 (SM_config2)</b>				
16 <sub>HEX</sub>	2:0	000 <sub>BIN</sub>	Gain_stage1	Gain setting for the 1 <sup>st</sup> PREAMP stage with Gain_stage1 ⇔ $Gain_{amp1}$ : 000 ⇔ 6 001 ⇔ 12 010 ⇔ 20 011 ⇔ 30 100 ⇔ 40 101 ⇔ 60 110 ⇔ 80 111 ⇔ 120 (Might affect noise and accuracy specifications depending on sensor setup)

MTP Address	Word / Bit Range	Default Setting	Description	Notes / Explanations
	5:3	000 <sub>BIN</sub>	Gain_stage2	Gain setting for the 2 <sup>nd</sup> PREAMP stage with Gain_stage2 ⇔ Gain <sub>amp2</sub> : 000 ⇔ 1.1 001 ⇔ 1.2 010 ⇔ 1.3 011 ⇔ 1.4 100 ⇔ 1.5 101 ⇔ 1.6 110 ⇔ 1.7 111 ⇔ 1.8
	6	0 <sub>BIN</sub>	Gain_polarity	Set up the polarity of the sensor bridge's gain (inverting of the chopper) with 0 ⇔ positive (no polarity change) 1 ⇔ negative (180° polarity change)
	10:7	0000 <sub>BIN</sub>	Adc_bits	Absolute number of bits for the ADC conversion ADC_bits: 0000 ⇔ 12-bit 0001 ⇔ 13-bit 0010 ⇔ 14-bit 0011 ⇔ 15-bit 0100 ⇔ 16-bit 0101 ⇔ 17-bit 0110 ⇔ 18-bit 0111 to 1111 ⇔ not assigned
	11	0 <sub>BIN</sub>	AbsV_enable	Enable bit for thermopile input selection (INN connected to AGND, INP connected to absolute voltage source) with AbsV_enable: 0 ⇔ absolute voltage input disabled (default) 1 ⇔ absolute voltage input enabled (e.g. for a thermopile)
	14:12	000 <sub>BIN</sub>	Offset	Differential signal's offset shift in the ADC; compensation of signal offset by x% of input signal: 000 ⇔ no offset compensation 001 ⇔ 6.75% offset 010 ⇔ 12.5% offset 011 ⇔ 19.25% offset 100 ⇔ 25% offset 101 ⇔ 31.75% offset 110 ⇔ 38.5% offset 111 ⇔ 43.25% offset  Note: Bit 15 below must be set to 1 to enable the offset shift.

MTP Address	Word / Bit Range	Default Setting	Description	Notes / Explanations
	15	0 <sub>BIN</sub>	Shift_method	Offset shift method switch: 0 ⇔ No offset shift. Offset (bits[14:12] in 16 <sub>HEX</sub> ) must be set to 000 <sub>BIN</sub> ; Gain <sub>ADC</sub> = 1 1 ⇔ Offset Shift ADC, Gain <sub>ADC</sub> = 2
<b>Post-Calibration Offset Correction Coefficients</b>				
17 <sub>HEX</sub>	15:0	0000 <sub>HEX</sub>	SENS_Shift[15:0]	Bits [15:0] of the post-calibration sensor offset shift coefficient SENS_Shift. (The MSB bits of SENS_Shift are bits [7:0] of register 19 <sub>HEX</sub> .)
18 <sub>HEX</sub>	15:0	0000 <sub>HEX</sub>	T_Shift[15:0]	Bits [15:0] of the post-calibration temperature offset shift coefficient T_Shift. (The MSB bits of T_Shift are bits [15:8] of register 19 <sub>HEX</sub> .)
19 <sub>HEX</sub>	7:0	00 <sub>HEX</sub>	SENS_Shift[23:16]	Bits [23:16] of the post-calibration sensor offset shift coefficient SENS_Shift. (The LSB bits of SENS_Shift are in register 17 <sub>HEX</sub> .)
	15:8	00 <sub>HEX</sub>	T_Shift[23:16]	Bits [23:16] of the post-calibration temperature offset shift coefficient T_Shift. (The LSB bits of T_Shift are in register 18 <sub>HEX</sub> .)
<b>Free Memory – Arbitrary Use</b>				
20 <sub>HEX</sub>	15:0	0000 <sub>HEX</sub>		Not assigned (e.g., can be used for Cust_IDx customer identification number)
21 <sub>HEX</sub>	15:0	0000 <sub>HEX</sub>		Not assigned (e.g., can be used for Cust_IDx customer identification number)
...				Not assigned (e.g., can be used for Cust_IDx customer identification number)
37 <sub>HEX</sub>	15:0	0000 <sub>HEX</sub>		Not assigned (e.g., can be used for Cust_IDx customer identification number)
38 <sub>HEX</sub>	15:0	0000 <sub>HEX</sub>		Not assigned (e.g., can be used for Cust_IDx customer identification number)
39 <sub>HEX</sub>	15:0	-	Checksum	Generated (checksum) for the entire memory through a linear feedback shift register (LFSR); signature is checked on power-up to ensure memory content integrity

The memory integrity checksum (referred to as CRC) is generated through a linear feedback shift register with the following polynomial:

$$g(x) = x^{16} + x^{15} + x^2 + 1 \quad \text{with the initialization value: FFFF}_{\text{HEX}}$$

If the CRC is valid, then the “Memory Error” status bit is set to 0.



### 3.7. Calibration Sequence

Calibration essentially involves collecting raw signal and temperature data from the sensor-ZSSC3218 system for different known sensor-element values (i.e., for a resistive bridge or an absolute voltage source) and temperatures. This raw data can then be processed by the calibration master (assumed to be the user's computer), and the calculated calibration coefficients can then be written to on-chip memory.

Here is a brief overview of the three main steps involved in calibrating the ZSSC3218.

1. *Assigning a unique identification to the ZSSC3218.* This identification is written to shadow RAM and programmed in MTP memory. This unique identification can be stored in the two 16-bit registers dedicated to the customer ID. It can be used as an index into a database stored on the calibration PC. This database will contain all the raw values of the connected sensor-element readings and temperature readings for that part, as well as the known sensor-element measurand conditions and temperature to which the sensor-element was exposed.
2. *Data collection.* Data collection involves getting uncorrected (raw) data from the external sensor at different known measurand values and temperatures. Then this data is stored on the calibration master using the unique identification of the device as the index to the database.
3. *Coefficient calculation and storage in MTP memory.* After enough data points have been collected to calculate all the desired coefficients, the coefficients can be calculated by the calibration master. Then the coefficients can be programmed to the MTP memory.

*Result.* The sensor signal and the characteristic temperature effect on output will be linearized according to the setup-dependent maximum output range.

It is essential to perform the calibration with a fixed programming setup during the data collection phase. In order to prevent any accidental misprocessing, it is further recommended to keep the MTP memory setup stable during the entire calibration process as well as in the subsequent operation. A ZSSC3218 calibration only fits the setup used during its calibration. Changes of functional parameters after a successful calibration can decrease the precision and accuracy performance of the ZSSC3218 as well as of the entire application.

The ZSSC3218 supports operation with different sensor setups by means of the *SM\_config1* and *SM\_config2* registers. However, only one calibration coefficient set is supported. Therefore, either an alternative ZSSC3218-external signal calibration using the alternate *SM\_config* settings must be performed to ensure that the programmed SSC coefficients are valid for both setups, or a full reprogramming of the SSC coefficients must be performed each time the sensor setup is changed. The selection of the external sensor setup (i.e., the AFE configuration) can be done with the interface commands B0<sub>HEX</sub> and B1<sub>HEX</sub>.

#### 3.7.1. Calibration Step 1 – Assigning Unique Identification

Assign a unique identification number to the ZSSC3218 by using the memory write command (40<sub>HEX</sub> + data and 41<sub>HEX</sub> + data; see Table 3.1 and Table 3.5) to write the identification number to Cust\_ID0 at memory address 00<sub>HEX</sub> and Cust\_ID1 at address 01<sub>HEX</sub> as described in section 3.6.1. These two 16-bit registers allow for more than 4 billion unique devices.

### 3.7.2. Calibration Step 2 – Data Collection

The number of unique points (measurand and/or temperature) at which calibration must be performed generally depends on the requirements of the application and the behavior of the sensor in use. The minimum number of points required is equal to the number of correction coefficients to be corrected with a minimum of three different temperatures at three different sensor values. For a full calibration resulting in values for all 7 possible (external) sensor coefficients and 3 possible temperature coefficients, a minimum of 7 pairs of sensor with temperature measurements must be collected.

Within this minimum field of 3 measurand measurements x 3 temperature measurements, data must be collected for the specific value pairs (at known conditions) and then processed to calculate the coefficients. In order to obtain the potentially best and most robust coefficients, it is recommended that measurement pairs (temperature vs. measurand) be collected at the outer corners of the intended operation range or at least at points that are located far from each other. It is also essential to provide highly precise reference values as nominal, expected values. The measurement precision of the external calibration-measurement equipment should be ten times more accurate than the expected ZSSC3218 output accuracy after calibration in order to avoid accuracy losses caused by the nominal reference values (e.g., measurand signal and temperature deviations).

Note: The coefficients *SENS\_shift* and *T\_shift* must not be determined during this calibration step. These coefficients can be pre-determined as zero until after initial calibration.

Note: *An appropriate selection of measurement pairs can significantly improve the overall system performance.*

The determination of the measurand-related coefficients will use all of the measurement pairs. For the temperature-related correction coefficients, 3 (at three different temperatures) of the measurement pairs will be used.

Note: *There is an inherent redundancy in the 7 sensor-related and 3 temperature-related coefficients. Since the temperature is a necessary output (which also needs correction), the temperature-related information is mathematically separated, which supports faster and more efficient DSP calculations during the normal usage of the sensor-ZSSC3218 system.* The recommended approach for data collection is to make use of the raw-measurement commands described in Table 3.2.

For external sensor values, either of the following commands can be used depending on the user's requirements:

- $A2_{\text{HEX}} + 0000_{\text{HEX}}$  single sensor measurement for which the configuration register will be loaded from the *SM\_Config1* register ( $12_{\text{HEX}}$  in MTP); preprogramming the measurement setup in the MTP is required.
- $A3_{\text{HEX}} + \text{ssss}_{\text{HEX}}$  single sensor measurement for which the *SM\_config* configuration register (Gain, ADC, Offset, etc.) will be loaded as the user's configuration  $\text{ssss}_{\text{HEX}}$ , which must be provided externally via the interface as the data part of this command.

For temperature values, either of the following commands can be used depending on the user's requirements:

- $A6_{\text{HEX}} + 0000_{\text{HEX}}$  single temperature measurement for which the configuration register will be loaded from an internal temperature configuration register (preprogrammed by IDT in the MTP); preprogramming of the respective configuration is done by IDT prior to ZSSC3218 delivery. This is the recommended approach for temperature data collection.

- $A7_{\text{HEX}} + \text{SSSS}_{\text{HEX}}$  single temperature measurement for which the configuration register (Gain, ADC, Offset, etc.) will be loaded as the user's configuration  $\text{SSSS}_{\text{HEX}}$ , which must be provided externally via the interface as the data part of this command. The format and purpose of these configuration bits must be according to the definitions for *SM\_config* and valid for temperature measurement in this case (bits [15:12] will be ignored).

### 3.7.3. Calibration Step 3a) – Coefficient Calculations

The math to perform the coefficient calculation is complicated and will not be discussed in detail. There is a brief overview in the next section. IDT provides software (DLLs) to perform the coefficient calculation (external to the sensor-ZSSC3218 system) based on auto-zero corrected values. After the coefficients are calculated, the final step is to write them to the MTP memory of the ZSSC3218.

### 3.7.4. Calibration Step 3b) – Post-Calibration Offset Correction

There are two special SSC coefficients, *SENS\_shift* and *T\_shift*. Normally, these coefficients must be predetermined as zero during the initial sensor calibration. The primary purpose of these two coefficients is to cancel additional offset shifts that could occur during or after final sensor assembly; e.g. if a respective sensor is finally placed and soldered on an application board.

If the final sensor assembly induced any kind of offset (on either the temperature or external sensor signal), the respective influence can be directly compensated by means of the *SENS\_shift* and *T\_shift* coefficients without the need to change the original SSC coefficient set. However, this post-calibration offset correction must be done under known ambient conditions (i.e., sensor measurand and/or temperature).

### 3.7.5. SSC Measurements

After the completion of the calibration procedure, linearized external sensor and temperature readings can be obtained using the commands  $AA_{\text{HEX}}$  to  $AF_{\text{HEX}}$  as described in Table 3.1.

Typically, only one external sensor is used in a single analog configuration using the setup in the *SM\_config1* MTP register ( $12_{\text{HEX}}$ ). However, the ZSSC3218 can support a second analog configuration that is set up in the *SM\_config2* MTP register ( $16_{\text{HEX}}$ ). This might be useful in cases where only one sensor-ZSSC3218 pair must support the measurand ranges for two different external sensors that have different precisions, required amplification, and sensor offset.

If a respective switching between setups is to be performed, the SSC coefficients for the alternate external sensor must be handled with one of the following methods:

- The programmed SSC coefficients are not used for the alternate external sensor. The ZSSC3218 performs only a factor-one transfer, i.e. no effective digital SSC correction – only a transfer of the auto-zero corrected raw ADC readings to the ZSSC3218 output without any scaling, etc.
- The coefficients are re-programmed each time the analog setup is changed.

*SM\_config1* is selected as the analog setup register by default, so no specific activation is needed if only *SM\_config1* is used. If *SM\_config2* will also be used, the activation command  $B1_{\text{HEX}}$  must be sent once prior to the measurement request. To switch to using *SM\_config1*, the activation command  $B0_{\text{HEX}}$  must be sent prior to use. This respective activation must be refreshed after any power-on-reset or RES pin reset.

### 3.8. The Calibration Math

#### 3.8.1. Bridge Signal Compensation

The saturation check in the ZSSC3218 detects saturation effects of the internal calculation steps, allowing the final correction output to be determined despite the saturation. It is possible to get potentially useful signal conditioning results that have had an intermediate saturation during the calculations. These cases are detectable by observing the status bit[0] for each measurement result. Details about the saturation limits and the valid ranges for values are provided in the following equations.

The calibration math description assumes a calculation with integer numbers. The description is numerically correct concerning values, dynamic range, and resolution.

*SOT\_curve* selects whether second-order equations compensate for sensor nonlinearity with a parabolic or S-shaped curve. The parabolic compensation is recommended for most sensor types.

**For the following equations, the terms are as follows:**

<i>S</i>	=	Corrected sensor reading output via I <sup>2</sup> C™ or SPI; range [0 <sub>HEX</sub> to FFFFFFF <sub>HEX</sub> ]
<i>S_Raw</i>	=	Raw sensor reading from ADC after AZ correction; range [-0x7FFFF, 0x7FFFF]
<i>Gain_S</i>	=	Sensor gain term; range [-0x7FFFF, 0x7FFFF]
<i>Offset_S</i>	=	Sensor offset term; range [-0x7FFFF, 0x7FFFF]
<i>Tcg</i>	=	Temperature coefficient gain term; range [-0x7FFFF, 0x7FFFF]
<i>Tco</i>	=	Temperature coefficient offset term; range [-0x7FFFF, 0x7FFFF]
<i>T_Raw</i>	=	Raw temperature reading after AZ correction; range [-0x7FFFF, 0x7FFFF]
<i>SOT_tcg</i>	=	Second-order term for Tcg non-linearity; range [-0x7FFFF, 0x7FFFF]
<i>SOT_tco</i>	=	Second-order term for Tco non-linearity; range [-0x7FFFF, 0x7FFFF]
<i>SOT_sens</i>	=	Second-order term for sensor non-linearity; range [-0x7FFFF, 0x7FFFF]
<i>SENS_shift</i>	=	post-calibration, post-assembly sensor offset shift; range [-0x7FFFF, 0x7FFFF]
$ \dots $	=	absolute value
$[\dots]_{ll}^{ul}$	=	bound/saturation number range from <i>ll</i> to <i>ul</i> , over/under-flow is reported as saturation in the status byte

The correction formula for the differential signal reading is represented as a two-step process depending on the *SOT\_curve* setting.

**Equations for the parabolic *SOT\_curve* setting (*SOT\_curve* = 0):**

*Simplified:*

$$K_1 = 2^{23} + \frac{T\_Raw}{2^{23}} \cdot \left( \frac{4 \cdot SOT\_tcg}{2^{23}} \cdot T\_Raw + 4 \cdot Tcg \right) \quad (1)$$

$$K_2 = 4 \cdot Offset\_S + S\_Raw + \frac{T\_Raw}{2^{23}} \cdot \left( \frac{4 \cdot SOT\_tco}{2^{23}} \cdot T\_Raw + 4 \cdot Tco \right) \quad (2)$$

$$Z_{SP} = \frac{4 \cdot Gain\_S}{2^{23}} \cdot \frac{K_1}{2^{23}} \cdot K_2 + 2^{23} \quad (\text{delimited to positive number range}) \quad (3)$$

$$S = \frac{Z_{BP}}{2^{23}} \cdot \left( \frac{4 \cdot SOT\_sens}{2^{23}} \cdot Z_{SP} + 2^{23} \right) + SENS\_shift \quad (\text{delimited to positive number range}) \quad (4)$$

Complete:

$$K_1 = \left[ 2^{23} + \left[ \frac{T\_Raw}{2^{23}} \cdot \left[ \left[ \frac{SOT\_tcg}{2^{21}} \cdot T\_Raw \right]_{-2^{25}}^{2^{25}-1} + 4Tcg \right]_{-2^{25}}^{2^{25}-1} \right]_{-2^{25}}^{2^{25}-1} \right]_{-2^{25}}^{2^{25}-1} \quad (5)$$

$$K_2 = \left[ 4 \cdot Offset\_S + \left[ S\_Raw + \left[ \frac{T\_Raw}{2^{23}} \cdot \left[ \left[ \frac{SOT\_tco}{2^{21}} \cdot T\_Raw \right]_{-2^{25}}^{2^{25}-1} + 4Tco \right]_{-2^{25}}^{2^{25}-1} \right]_{-2^{25}}^{2^{25}-1} \right]_{-2^{25}}^{2^{25}-1} \right]_{-2^{25}}^{2^{25}-1} \quad (6)$$

$$Z_{SP} = \left[ \left[ \frac{Gain\_S}{2^{21}} \cdot \left[ \left[ \frac{K_1}{2^{23}} \cdot K_2 \right]_{-2^{25}}^{2^{25}-1} \right]_{-2^{25}}^{2^{25}-1} + 2^{23} \right]_0^{2^{25}-1} \right]_{-2^{25}}^{2^{25}-1} \quad (7)$$

$$B = \left[ \left[ \frac{Z_{SP}}{2^{23}} \cdot \left[ \left[ \frac{SOT\_sens}{2^{21}} \cdot Z_{BP} \right]_{-2^{25}}^{2^{25}-1} + 2^{23} \right]_{-2^{25}}^{2^{25}-1} + SENS\_shift \right]_0^{2^{24}-1} \right]_{-2^{25}}^{2^{25}-1} \quad (8)$$

**Equations for the S-shaped SOT\_curve setting (SOT\_curve = 1):**

Simplified:

$$Z_{SS} = \frac{4 \cdot Gain\_S}{2^{23}} \cdot \frac{K_1}{2^{23}} \cdot K_2 \quad (9)$$

$$S = \frac{Z_{SS}}{2^{23}} \cdot \left( \frac{4 \cdot SOT\_sens}{2^{23}} \cdot |Z_{SS}| + 2^{23} \right) + 2^{23} + SENS\_shift \quad (\text{delimited to positive number range}) \quad (10)$$

Complete:

$$Z_{SS} = \left[ \frac{Gain\_S}{2^{21}} \cdot \left[ \left[ \frac{K_1}{2^{23}} \cdot K_2 \right]_{-2^{25}}^{2^{25}-1} \right]_{-2^{25}}^{2^{25}-1} \right]_{-2^{25}}^{2^{25}-1} \quad (11)$$

$$S = \left[ \left[ \frac{Z_{SS}}{2^{23}} \cdot \left[ \left[ \frac{SOT\_sens}{2^{21}} \cdot |Z_{SS}| \right]_{-2^{25}}^{2^{25}-1} + 2^{23} \right]_{-2^{25}}^{2^{25}-1} + 2^{23} + SENS\_shift \right]_0^{2^{24}-1} \right]_{-2^{25}}^{2^{25}-1} \quad (12)$$

### 3.8.2. Temperature Signal Compensation

Temperature is measured internally. Temperature correction contains both linear gain and offset terms as well as a second-order term to correct for any nonlinearities. For temperature, second-order compensation for nonlinearity is always parabolic.

The correction formula is best represented as a two-step process as follows:

*Simplified:*

$$Z_T = \frac{4 \cdot Gain\_T}{2^{23}} \cdot (T\_Raw + 4 \cdot Offset\_T) + 2^{23} \quad (\text{delimited to positive number range}) \quad (13)$$

$$T = \frac{Z_T}{2^{23}} \cdot \left( \frac{4 \cdot SOT\_T}{2^{23}} \cdot Z_T + 2^{23} \right) + T\_Shift \quad (\text{delimited to positive number range}) \quad (14)$$

*Complete:*

$$Z_T = \left[ \left[ \frac{Gain\_T}{2^{21}} \cdot [T\_Raw + 4Offset\_T]_{-2^{25}}^{2^{25}-1} \right]_{-2^{25}}^{2^{25}-1} + 2^{23} \right]_0^{2^{25}-1} \quad (15)$$

$$T = \left[ \frac{Z_T}{2^{23}} \cdot \left[ \left[ \frac{SOT\_T}{2^{21}} \cdot Z_T \right]_{-2^{25}}^{2^{25}-1} + 2^{23} \right]_{-2^{25}}^{2^{25}-1} + T\_Shift \right]_0^{2^{24}-1} \quad (16)$$

#### Where

- $T$  = Corrected temperature sensor reading output via I<sup>2</sup>C™ or SPI; range [0<sub>HEX</sub> to FFFFFFF<sub>HEX</sub>]
- $Gain\_T$  = Gain coefficient for temperature; range [-7FFFFFF<sub>HEX</sub> to 7FFFFFF<sub>HEX</sub>]
- $T\_Raw$  = Raw temperature reading after AZ correction; range [-7FFFFFF<sub>HEX</sub> to 7FFFFFF<sub>HEX</sub>]
- $Offset\_T$  = Offset coefficient for temperature; range [-7FFFFFF<sub>HEX</sub> to 7FFFFFF<sub>HEX</sub>]
- $SOT\_T$  = Second-order term for temperature source non-linearity; range [-7FFFFFF<sub>HEX</sub> to 7FFFFFF<sub>HEX</sub>]
- $T\_Shift$  = Shift for post-calibration/post-assembly offset compensation; range [-7FFFFFF<sub>HEX</sub> to 7FFFFFF<sub>HEX</sub>]

### 3.8.3. Measurement Output Data Format

The data format and bit assignment of the raw measurement and SSC-corrected outputs of the ZSSC3218 are defined in the following tables. Any ADC measurement and SSC calculation output is formatted as a 24-bit wide data word, regardless of the effective ADC resolution used. The values are either in two's complement or sign-absolute format.

**Table 3.6 Measurement Results of ADC Raw Measurement Request (two's complement)**

Bit	23	22	21	20	...	1	0
Meaning, Weighting	$-2^0$	$2^{-1}$	$2^{-2}$	$2^{-3}$	...	$2^{-22}$	$2^{-23}$

**Table 3.7 Calibration Coefficients (Factors and Summands) in Memory (sign-magnitude)**

Bit	23	22	21	20	...	1	0
Meaning, weighting	0=positive 1=negative	$2^1$	$2^0$	$2^{-1}$	...	$2^{-20}$	$2^{-21}$

**Table 3.8 Output Results from SSC-Correction Math or DSP—Sensor and Temperature**

Bit	23	22	21	20	...	1	0
Meaning, weighting	$2^0$	$2^{-1}$	$2^{-2}$	$2^{-3}$	...	$2^{-22}$	$2^{-23}$

**Table 3.9 Interrupt Thresholds TRSH1 and TRSH2—Format as for SSC-Correction Math Output**

Bit	23	22	21	20	...	1	0
Meaning, weighting	$2^0$	$2^{-1}$	$2^{-2}$	$2^{-3}$	...	$2^{-22}$	$2^{-23}$



## 4 Package Information and Pad Assignments

The ZSSC3218 is available in die form or as engineering samples in the PQFN24 package. See Figure 4.1 for additional die dimensions.

In Figure 4.1, the outer dimensions shown are (minimum) estimations for a die after sawing without remaining scribe-line silicon around the core die. Therefore, the effective outer dimensions might differ slightly.

**Figure 4.1 ZSSC3218 Pad Placement**

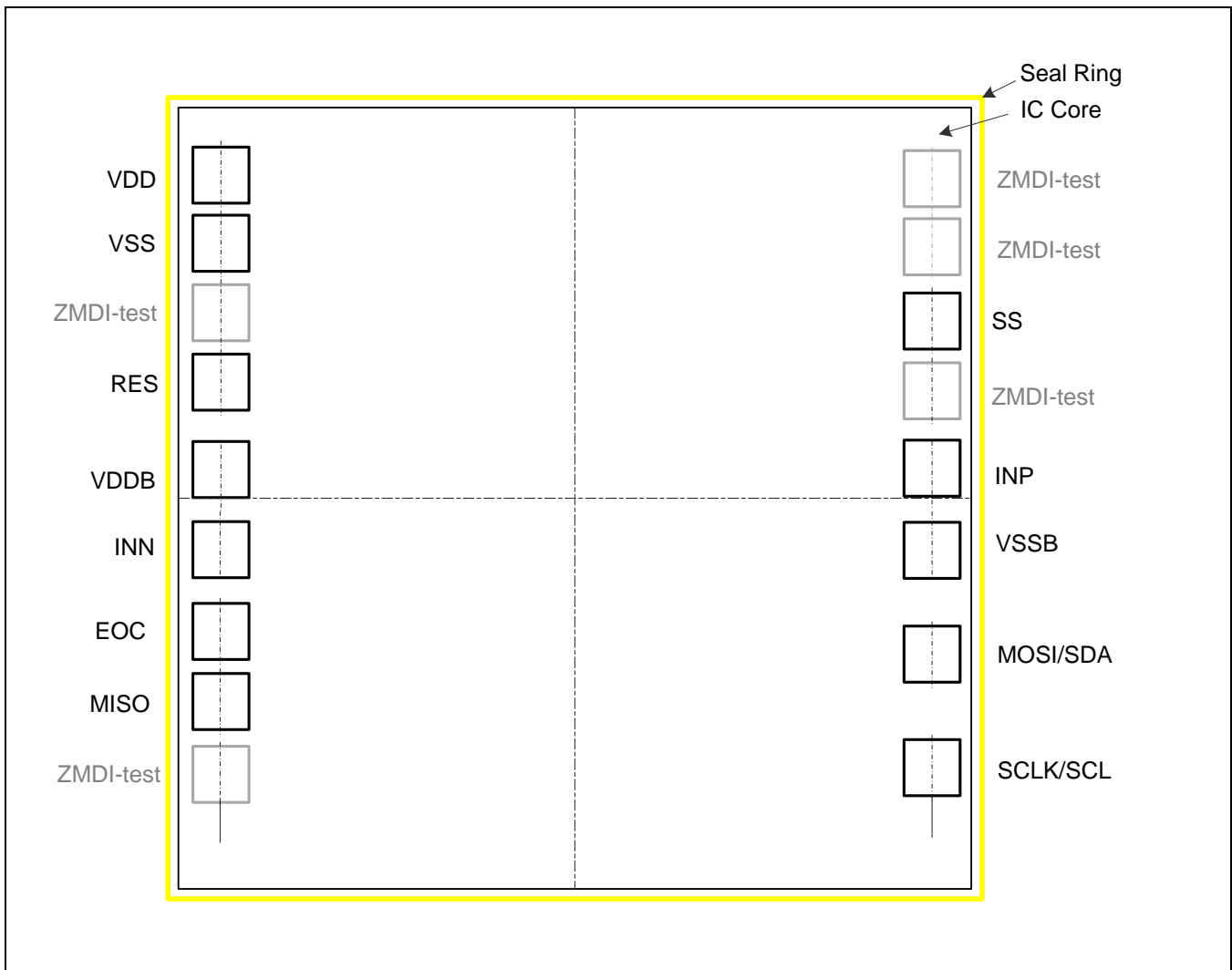

**Table 4.1 Pad Assignments**

Name	Direction	Type	Description
VDD	IN	Supply	IC positive supply voltage for the IC.
VSS	IN	Supply	Ground reference voltage signal.
RES	IN	Digital	IC reset (low active, internal pull-up).
Vddb	OUT	Analog	Positive external bridge-sensor supply.
INN	IN	Analog	Negative sensor signal (or sensor-ground for absolute voltage-sources sensors).
EOC	OUT	Digital	End of conversion or interrupt output.
MISO	OUT	Digital	Data output for SPI.
SS	IN	Digital	Slave select for SPI.
INP	IN	Analog	Positive sensor signal.
VSSB	OUT	Analog	Negative external bridge-sensor supply (sensor ground).
MOSI/SDA	IN/Out	Digital	Data input for SPI; data in/out for I <sup>2</sup> C™.
SCLK/SCL	IN	Digital	Clock input for I <sup>2</sup> C™/SPI.
ZMDI-test	-	-	Do not connect to these pads.

**Table 4.2 Die Connection and Bond Parameter**

Parameter	TYP	MAX	Description / Notes
Au Bond, Pull-Force	-	8g	Soft bonding recommended.
Cu Bond, Pull-Force	not specified		Strongly not recommended.
Contact Push-Force to Pad	0.05g/μm	0.1g/μm	Applied force during wafer sort and/or bond-wire connection.
Probing Overdrive	-	55μm	Up to 4 touch downs at 85°C maximum; cantilever probe.

Generally, it is strongly recommended that bond and connection experiments be conducted in order to determine a proper assembly setup (golden wire, time, power, bonding force, etc. by means of wire-pull test, ball-shear test, and others) that does not lead to any IC and/or pad damages. Higher bond pull-forces maybe possible depending directly on the bond tool and temperature.

Figure 4.2 General PQFN24 Package Dimensions

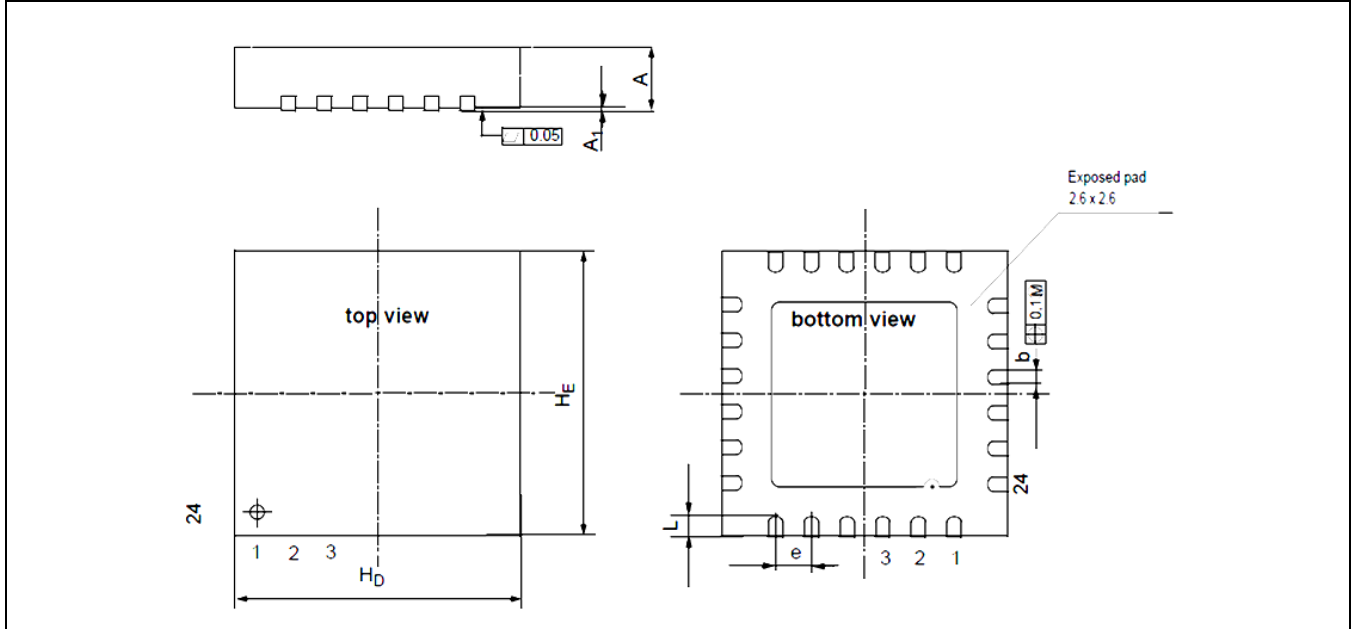

Table 4.3 Physical Package Dimensions

Parameter / Dimension	Min (mm)	Max (mm)
A	0.80	0.90
A <sub>1</sub>	0.00	0.05
b	0.18	0.30
e	0.5nom	
H <sub>D</sub>	3.90	4.10
H <sub>E</sub>	3.90	4.10
L	0.35	0.45

**Table 4.4 Pin Assignments PQFN24**

Pin No.	Name <sup>1)</sup>	Direction	Type	Description
1	ZMDI-test	-	-	Do not connect.
2	RES	IN	Digital	IC reset (low active, internal pull-up).
3	VDDDB	OUT	Analog	Positive external bridge-sensor supply.
4	INN	IN	Analog	Negative sensor signal (or sensor ground for absolute voltage-source sensors).
5	EOC	OUT	Digital	End of conversion or interrupt output.
6	MISO	OUT	Digital	Data output for SPI.
7	ZMDI-test	-	-	Do not connect.
8	n.c.	-	-	-
9	n.c.	-	-	-
10	n.c.	-	-	-
11	n.c.	-	-	-
12	SCLK/SCL	IN	Digital	Clock input for I <sup>2</sup> C™/SPI.
13	MOSI/SDA	IN/Out	Digital	Data input for SPI; data in/out for I <sup>2</sup> C™.
14	VSSB	OUT	Analog	Negative external bridge-sensor supply (sensor ground).
15	INP	IN	Analog	Positive sensor signal.
16	ZMDI-test	-	-	Do not connect.
17	SS	IN	Digital	Slave select for SPI
18	ZMDI-test	-	-	Do not connect.
19	ZMDI-test	-	-	Do not connect.
20	n.c.	-	-	-
21	n.c.	-	-	-
22	VDD	IN	Supply	IC positive supply voltage for the ZSSC3218.
23	n.c.	-	-	-
24	VSS	IN	Supply	Ground reference voltage signal.
25	Exposed Pad	-	-	Do not connect electrically.

1) n.c. stands for not connected / no connection required / not bonded.

## 5 Quality and Reliability

The ZSSC3218 is available as a qualified IC for consumer-market applications. All data specified parameters are guaranteed if not stated otherwise.

## 6 Ordering Sales Codes

Sales Code	Description	Package
ZSSC3218BI1B	Die—temperature range: –40°C to +85 °C, thickness 304µm	Unsawn wafer
ZSSC3218BI2B	Die—temperature range: –40°C to +85 °C, thickness 725µm (w/o backlapping)	Unsawn wafer
ZSSC3218BI3R ES	PQFN24—temperature range: –40°C to +85 °C, <i>engineering samples</i>	Packaged die

Contact IDT Sales for additional information.

## 7 Related Documents

Document
ZSSC3218 Feature Sheet

Visit the ZSSC3218 product page [www.IDT.com/ZSSC3218](http://www.IDT.com/ZSSC3218) or contact your nearest sales office for ordering information or the latest version of these documents.

## 8 Glossary

Term	Description
A2D	Analog-to-Digital
ACK	Acknowledge (interface's protocol indicator for successful data/command transfer)
ADC	Analog-to-Digital Converter or Conversion
ALU	Arithmetic Logic Unit
AZ	Auto-Zero (unspecific)
AZSM	Auto-Zero Measurement for (external) Sensor Path
AZTM	Auto-Zero Measurement for Temperature Path
Au	Gold
CLK	Clock
Cu	Copper
DAC	Digital-to-Analog Conversion or Converter
DF	Data Fetch (command type)
DSP	Digital Signal Processor
EOC	End of Conversion
FSO	Full Scale Output (value in percent relative to the ADC maximum output code; resolution dependent)
LSB	Least Significant Bit
LFSR	Linear Feedback Shift Register
MR	Measurement Request (command type)
MSB	Most Significant Bit
MTP	Multiple-Time Programmable Memory
NACK	Not Acknowledge (interface's protocol indicator for unsuccessful data/command transfer)
POR	Power-on Reset
PreAmp	Preamplifier
PSRR	Power Supply Disturbance Rejection Ratio
SM	Signal Measurement
SOT	Second-Order Term
TC	Temperature Coefficient (of a resistor or the equivalent bridge resistance)
TM	Temperature Measurement

## 9 Document Revision History

Revision	Date	Description
1.00	August 21, 2014	First release.
1.01	September 11, 2014	Update for Sleep State current on page 2. Minor edits.
1.02	October 2, 2014	Update of SSC-noise values in Table 2.6.
1.03	November 17, 2014	Corrections in Table 3.5 for settings for CYC_period, Gain_stage1, Gain_stage2, Adc_bits and Offset. Correction for Figure 2.3.
	April 20, 2016	Changed to IDT branding.

## IMPORTANT NOTICE AND DISCLAIMER

RENESAS ELECTRONICS CORPORATION AND ITS SUBSIDIARIES (“RENESAS”) PROVIDES TECHNICAL SPECIFICATIONS AND RELIABILITY DATA (INCLUDING DATASHEETS), DESIGN RESOURCES (INCLUDING REFERENCE DESIGNS), APPLICATION OR OTHER DESIGN ADVICE, WEB TOOLS, SAFETY INFORMATION, AND OTHER RESOURCES “AS IS” AND WITH ALL FAULTS, AND DISCLAIMS ALL WARRANTIES, EXPRESS OR IMPLIED, INCLUDING, WITHOUT LIMITATION, ANY IMPLIED WARRANTIES OF MERCHANTABILITY, FITNESS FOR A PARTICULAR PURPOSE, OR NON-INFRINGEMENT OF THIRD PARTY INTELLECTUAL PROPERTY RIGHTS.

These resources are intended for developers skilled in the art designing with Renesas products. You are solely responsible for (1) selecting the appropriate products for your application, (2) designing, validating, and testing your application, and (3) ensuring your application meets applicable standards, and any other safety, security, or other requirements. These resources are subject to change without notice. Renesas grants you permission to use these resources only for development of an application that uses Renesas products. Other reproduction or use of these resources is strictly prohibited. No license is granted to any other Renesas intellectual property or to any third party intellectual property. Renesas disclaims responsibility for, and you will fully indemnify Renesas and its representatives against, any claims, damages, costs, losses, or liabilities arising out of your use of these resources. Renesas' products are provided only subject to Renesas' Terms and Conditions of Sale or other applicable terms agreed to in writing. No use of any Renesas resources expands or otherwise alters any applicable warranties or warranty disclaimers for these products.

(Rev.1.0 Mar 2020)

### Corporate Headquarters

TOYOSU FORESIA, 3-2-24 Toyosu,  
Koto-ku, Tokyo 135-0061, Japan  
[www.renesas.com](http://www.renesas.com)

### Contact Information

For further information on a product, technology, the most up-to-date version of a document, or your nearest sales office, please visit:  
[www.renesas.com/contact/](http://www.renesas.com/contact/)

### Trademarks

Renesas and the Renesas logo are trademarks of Renesas Electronics Corporation. All trademarks and registered trademarks are the property of their respective owners.