



## Reference Specification

### DEH Series

High Temperature Low Loss Lead Type Disc Ceramic Capacitors of class 2 for General Purpose

Product specifications in this catalog are as of Dec. 2017, and are subject to change or obsolescence without notice.

Please consult the approval sheet before ordering. Please read rating and Cautions first.

## Reference only

### ⚠ CAUTION

#### 1. OPERATING VOLTAGE

When DC-rated capacitors are to be used in AC or ripple current circuits, be sure to maintain the  $V_{p-p}$  value of the applied voltage or the  $V_{o-p}$  which contains DC bias within the rated voltage range.

When the voltage is started to apply to the circuit or it is stopped applying, the irregular voltage may be generated for a transit period because of resonance or switching. Be sure to use a capacitor within rated voltage containing these irregular voltage.

When DC-rated capacitors are to be used in input circuits from commercial power source (AC filter), be sure to use Safety Recognized Capacitors because various regulations on withstand voltage or impulse withstand established for each equipment should be taken into considerations.

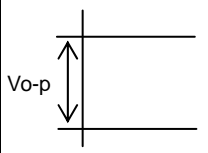
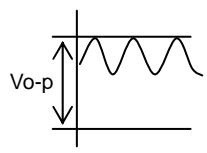
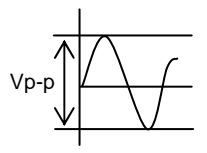
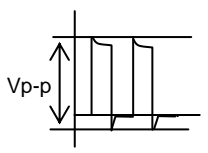
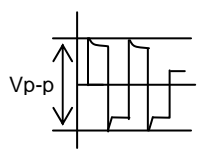
Voltage	DC Voltage	DC+AC Voltage	AC Voltage	Pulse Voltage(1)	Pulse Voltage(2)
Positional Measurement					

#### 2. OPERATING TEMPERATURE AND SELF-GENERATED HEAT

Keep the surface temperature of a capacitor below the upper limit of its rated operating temperature range. Be sure to take into account the heat generated by the capacitor itself.

When the capacitor is used in a high-frequency current, pulse current or the like, it may have the self-generated heat due to dielectric-loss. The allowable frequency should be in less than 300kHz in sine wave. Applied voltage should be the load such as self-generated heat is within 20 °C on the condition of atmosphere temperature 25 °C. When measuring, use a thermocouple of small thermal capacity-K of  $\phi 0.1\text{mm}$  and be in the condition where capacitor is not affected by radiant heat of other components and wind of surroundings. (Never attempt to perform measurement with the cooling fan running. Otherwise, accurate measurement cannot be ensured.)

#### 3. FAIL-SAFE

When capacitor would be broken, failure may result in a short circuit. Be sure to provide an appropriate fail-safe function like a fuse on your product if failure would follow an electric shock, fire or fume.

#### 4. LOAD REDUCTION AND SELF-GENERATED HEAT DURING APPLICATION OF HIGH-FREQUENCY AND HIGH-VOLTAGE

Since the heat generated by the low-dissipation capacitor itself is low, its allowable power is much higher than the general B characteristic. However, in case such an applied load that the self-heating temperature is 20 °C at the rated voltage, the allowable power may be exceeded.

Therefore, when using the low-dissipation capacitors in a high-frequency and high-voltage circuit with a frequency of 1kHz or higher, make sure that the Vp-p values including the DC bias, do not exceed the applied voltage value specified in Table 1. Also make sure that the self-heating temperature (the difference between the capacitor's surface temperature and the capacitor's ambient temperature) at an ambient temperature of 25 °C does not exceed the value specified in Table 1.

As shown in Fig. 2, the self-heating temperature depends on the ambient temperature. Therefore, if you are not able to set the ambient temperature to approximately 25 °C, please contact our sales representatives or product engineers.

<Table 1> Allowable Conditions at High-frequency

Temp. Char.	DC Rated Voltage	Allowable Conditions at High-frequency *3		Capacitor's Ambient Temp. *2
		Applied Voltage (max.)	Self-heating Temp. (25 °C Ambient Temp.) *1	
R	250V	250Vp-p	10 °C max.	-25 to +85 °C
C	500V	500Vp-p	20 °C max.	
R	1kV	800Vp-p	20 °C max.	
		1000Vp-p	5 °C max.	
	2kV	1400Vp-p	20 °C max.	
		2000Vp-p	5 °C max.	
	3.15kV	1600Vp-p	20 °C max.	
		3150Vp-p	5 °C max.	

\*1 Fig. 1 shows the relationship between the applied voltage and the allowable self-heating temperature regarding 1 to 3.15kV rated voltage of the DEH series R characteristic.

\*2 When the ambient temperature is 85 to 125 °C, the applied voltage needs to be further reduced. If the low-dissipation capacitors needs to be used at an ambient temperature of 85 to 125 °C, please contact our sales representatives or product engineers.

\*3 Fig. 3 shows reference data on the allowable voltage-frequency characteristic for a sine wave voltage.

<Fig. 1> Relationship Between Applied Voltage and Self-heating Temperature [Allowable Self-heating Temp. at 25 °C Ambient Temp. ]

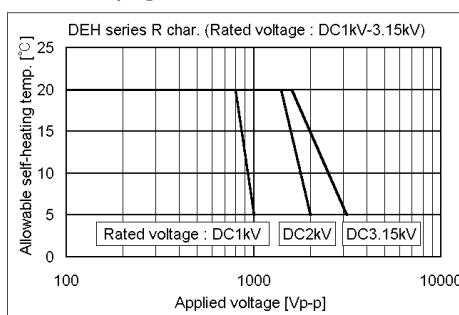

<Fig. 2> Dependence of Self-heating Temperature on Ambient Temperature

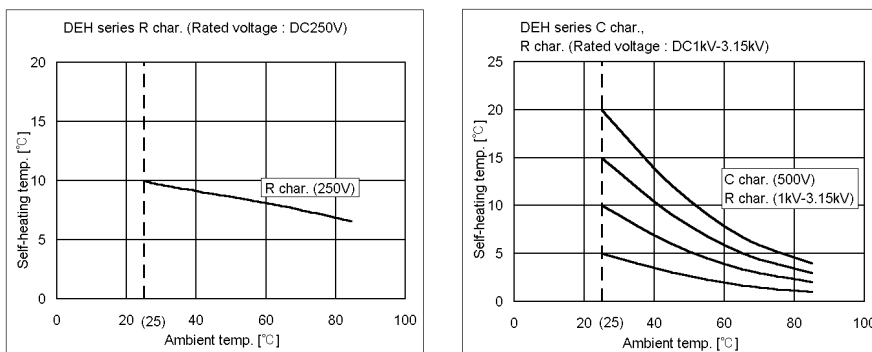

## Reference only

<Fig. 3> Allowable Voltage (Sine Wave Voltage) – Frequency Characteristic [At Ambient Temperature of 85 °C or less]

Because of the influence of harmonics, when the applied voltage is a rectangular wave or pulse wave voltage (instead of a sine wave voltage), the heat generated by the capacitor is higher than the value obtained by application of the sine wave with the same fundamental frequency. Roughly calculated for reference, the allowable voltage for a rectangular wave or pulse wave corresponds approximately to the allowable voltage for a sine wave whose fundamental frequency is twice as large as that of the rectangular wave or pulse wave. This allowable voltage, however, varies depending on the voltage and current waveforms. Therefore, you are requested to make sure that the self-heating temperature is not higher than the value specified in Table 1.

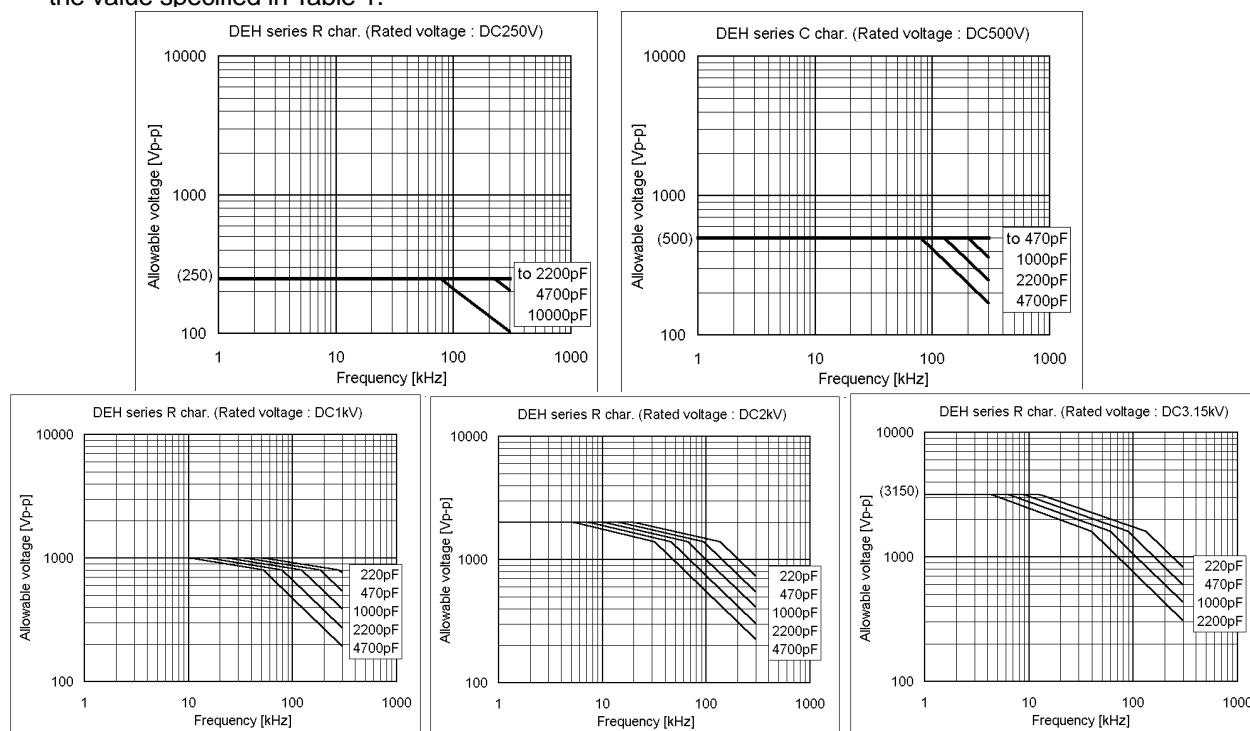

### 5. VIBRATION AND IMPACT

Do not expose a capacitor or its leads to excessive shock or vibration during use.

### 6. SOLDERING

When soldering this product to a PCB/PWB, do not exceed the solder heat resistance specification of the capacitor. Subjecting this product to excessive heating could melt the internal junction solder and may result in thermal shocks that can crack the ceramic element.

When soldering capacitor with a soldering iron, it should be performed in following conditions.

Temperature of iron tip : 400 °C max.

Soldering iron wattage : 50W max.

Soldering time : 3.5 s max.

### 7. BONDING, RESIN MOLDING AND COATING

In case of bonding, molding or coating this product, verify that these processes do not affect the quality of capacitor by testing the performance of the bonded, molded or coated product in the intended equipment.

In case of the amount of applications, dryness / hardening conditions of adhesives and molding resins containing organic solvents (ethyl acetate, methyl ethyl ketone, toluene, etc.) are unsuitable, the outer coating resin of a capacitor is damaged by the organic solvents and it may result, worst case, in a short circuit.

The variation in thickness of adhesive, molding resin or coating may cause a outer coating resin cracking and/or ceramic element cracking of a capacitor in a temperature cycling.

## Reference only

### 8. TREATMENT AFTER BONDING, RESIN MOLDING AND COATING

When the outer coating is hot (over 100 °C) after soldering, it becomes soft and fragile.  
So please be careful not to give it mechanical stress.

Failure to follow the above cautions may result, worst case, in a short circuit and cause fuming or partial dispersion when the product is used.

### 9. OPERATING AND STORAGE ENVIRONMENT

The insulating coating of capacitors does not form a perfect seal; therefore, do not use or store capacitors in a corrosive atmosphere, especially where chloride gas, sulfide gas, acid, alkali, salt or the like are present. And avoid exposure to moisture. Before cleaning, bonding, or molding this product, verify that these processes do not affect product quality by testing the performance of a cleaned, bonded or molded product in the intended equipment. Store the capacitors where the temperature and relative humidity do not exceed -10 to 40 °C and 15 to 85%. Use capacitors within 6 months after delivered. Check the solderability after 6 months or more.

### 10. LIMITATION OF APPLICATIONS

Please contact us before using our products for the applications listed below which require especially high reliability for the prevention of defects which might directly cause damage to the third party's life, body or property.

1. Aircraft equipment
2. Aerospace equipment
3. Undersea equipment
4. Power plant control equipment
5. Medical equipment
6. Transportation equipment (vehicles, trains, ships, etc.)
7. Traffic signal equipment
8. Disaster prevention / crime prevention equipment
9. Data-processing equipment exerting influence on public
10. Application of similar complexity and/or reliability requirements to the applications listed in the above.

### NOTICE

#### 1. CLEANING (ULTRASONIC CLEANING)

To perform ultrasonic cleaning, observe the following conditions.

Rinse bath capacity : Output of 20 watts per liter or less.

Rinsing time : 5 min maximum.

Do not vibrate the PCB/PWB directly.

Excessive ultrasonic cleaning may lead to fatigue destruction of the lead wires.

#### 2. CAPACITANCE CHANGE OF CAPACITORS

- Class 1 capacitors

Capacitance might change a little depending on a surrounding temperature or an applied voltage.

Please contact us if you use for the strict time constant circuit.

- Class 2 and 3 capacitors

Class 2 and 3 capacitors like temperature characteristic B, E and F have an aging characteristic, whereby the capacitor continually decreases its capacitance slightly if the capacitor leaves for a long time. Moreover, capacitance might change greatly depending on a surrounding temperature or an applied voltage. So, it is not likely to be able to use for the time constant circuit.

Please contact us if you need a detail information.

### NOTE

1. Please make sure that your product has been evaluated in view of your specifications with our product being mounted to your product.
2. You are requested not to use our product deviating from this specification.

## Reference only

### 1. Application

This specification is applied to High Temperature Low Loss Lead Type Disc Ceramic Capacitors of Class 2 of DEH series used for General Electric equipment.

Do not use these products in any automotive power train or safety equipment including battery chargers for electric vehicles and plug-in hybrids.

### 2. Rating

#### 2-1. Operating temperature range

-25 ~ +125°C

#### 2-2. Part number configuration

ex.) 

DEH	R3	3F	102	K	B3	B	
Series	Temperature characteristic	Rated voltage	Capacitance	Capacitance tolerance	Lead code	Packing style code	Individual specification

- Temperature characteristic

Code	Temperature characteristic
R3	R

Please confirm detailed specification on [ Specification and test methods ].

- Rated voltage

Code	Rated voltage
3D	DC2kV
3F	DC3.15kV

- Capacitance

The first two digits denote significant figures ; the last digit denotes the multiplier of 10 in pF.  
ex.) In case of 102.

$$10 \times 10^2 = 1000\text{pF}$$

- Capacitance tolerance

Please refer to [ Part number list ].

- Lead code

Code	Lead style
A*	Vertical crimp long type
C*	Straight long type
B*	Vertical crimp short type
D*	Straight short type
N*	Vertical crimp taping type
P*	Straight taping type

\* Please refer to [ Part number list ].

Solder coated copper wire is applied for termination.

- Packing style code

Code	Packing type
B	Bulk type
A	Ammo pack taping type

- Individual specification

In case part number cannot be identified without 'individual specification' , it is added at the end of part number.

## Reference only

### 3. Marking

High temperature guaranteed code : HR  
Temperature characteristic : Letter code  
Nominal capacitance : 3 digit system  
Capacitance tolerance : Code  
Rated voltage : Letter code(In case of DC3.15kV, marked with 3KV)  
Company name code : Abbreviation   
(Omitted for maximum body diameter  $\phi$  9mm and under)  
Manufacturing date : Abbreviation

ex.) YEAR                      MONTH  
      2010                      12(December)  
      └───┬───┘            └───┬───┘  
          OD\*               

\* From January to September : "1" to "9",  
October : "O" , November : "N" , December : "D"

(Example)

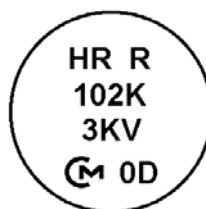

## Reference only

### 4. Part number list

-Straight long type  
(Lead code: C\*)

-Vertical crimp long type  
(Lead code: A\*)

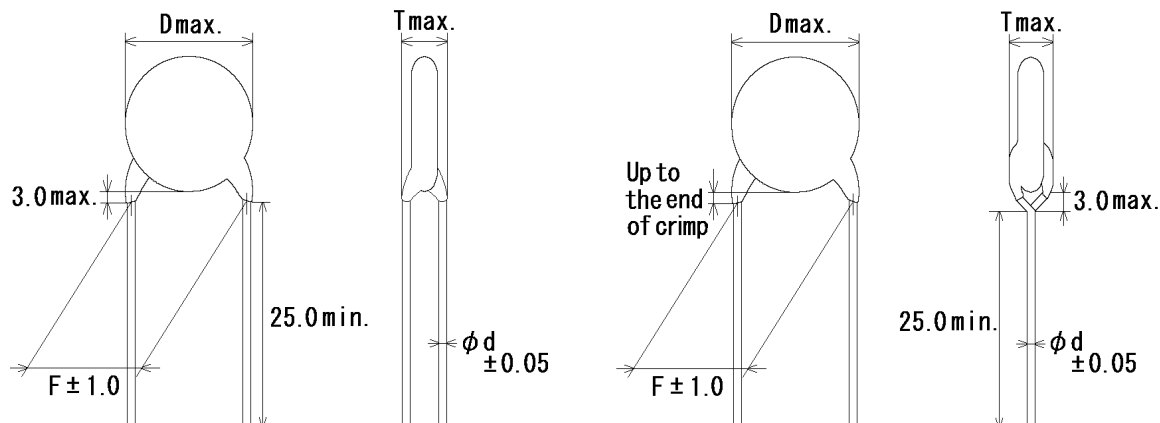

Note) The mark '\*' of lead code differ from lead spacing(F) and lead diameter(d).  
Please see the following list about details.

Unit : mm

T.C.	Cap. (pF)	Cap. tol.	Customer Part Number	Murata Part Number	DC Rated Volt. (V)	Dimension (mm)				Lead Code	Pack qty. (pcs)
						D	T	F	d		
R	220	±10%		DEHR33D221KC3B	2000	7.0	5.0	7.5	0.6	C3	250
R	270	±10%		DEHR33D271KC3B	2000	7.0	5.0	7.5	0.6	C3	250
R	330	±10%		DEHR33D331KA3B	2000	8.0	5.0	7.5	0.6	A3	250
R	390	±10%		DEHR33D391KA3B	2000	8.0	5.0	7.5	0.6	A3	250
R	470	±10%		DEHR33D471KA3B	2000	9.0	5.0	7.5	0.6	A3	250
R	560	±10%		DEHR33D561KA3B	2000	9.0	5.0	7.5	0.6	A3	250
R	680	±10%		DEHR33D681KA3B	2000	10.0	5.0	7.5	0.6	A3	250
R	820	±10%		DEHR33D821KA3B	2000	11.0	5.0	7.5	0.6	A3	250
R	1000	±10%		DEHR33D102KA3B	2000	12.0	5.0	7.5	0.6	A3	200
R	1200	±10%		DEHR33D122KA3B	2000	12.0	5.0	7.5	0.6	A3	200
R	1500	±10%		DEHR33D152KA3B	2000	12.0	5.0	7.5	0.6	A3	200
R	1800	±10%		DEHR33D182KA3B	2000	14.0	5.0	7.5	0.6	A3	200
R	2200	±10%		DEHR33D222KA3B	2000	15.0	5.0	7.5	0.6	A3	100
R	2700	±10%		DEHR33D272KA3B	2000	17.0	5.0	7.5	0.6	A3	100
R	3300	±10%		DEHR33D332KA4B	2000	19.0	5.0	10.0	0.6	A4	50
R	3900	±10%		DEHR33D392KA4B	2000	20.0	5.0	10.0	0.6	A4	50
R	4700	±10%		DEHR33D472KA4B	2000	21.0	5.0	10.0	0.6	A4	50
R	150	±10%		DEHR33F151KC3B	3150	7.0	6.0	7.5	0.6	C3	250
R	180	±10%		DEHR33F181KC3B	3150	7.0	6.0	7.5	0.6	C3	250
R	220	±10%		DEHR33F221KC3B	3150	7.0	6.0	7.5	0.6	C3	250
R	270	±10%		DEHR33F271KC3B	3150	7.0	6.0	7.5	0.6	C3	250
R	330	±10%		DEHR33F331KA3B	3150	8.0	6.0	7.5	0.6	A3	250
R	390	±10%		DEHR33F391KA3B	3150	9.0	6.0	7.5	0.6	A3	250
R	470	±10%		DEHR33F471KA3B	3150	10.0	6.0	7.5	0.6	A3	250
R	560	±10%		DEHR33F561KA3B	3150	10.0	6.0	7.5	0.6	A3	250
R	680	±10%		DEHR33F681KA3B	3150	11.0	6.0	7.5	0.6	A3	250
R	820	±10%		DEHR33F821KA3B	3150	12.0	6.0	7.5	0.6	A3	200



## Reference only

Vertical crimp long type  
(Lead code:A\*)

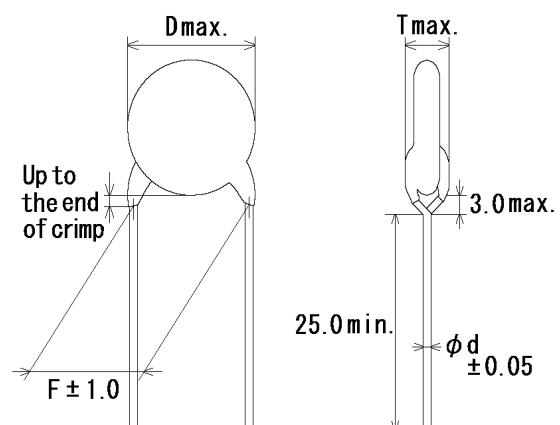

Unit : mm

Note) The mark '\*' of lead code differ from lead spacing(F) and lead diameter(d).  
Please see the following list about details.

T.C.	Cap. (pF)	Cap. tol.	Customer Part Number	Murata Part Number	DC Rated Volt. (V)	Dimension (mm)				Lead Code	Pack qty. (pcs)
						D	T	F	d		
R	1000	±10%		DEHR33F102KA3B	3150	13.0	6.0	7.5	0.6	A3	200
R	1200	±10%		DEHR33F122KA3B	3150	14.0	6.0	7.5	0.6	A3	200
R	1500	±10%		DEHR33F152KA3B	3150	15.0	6.0	7.5	0.6	A3	100
R	1800	±10%		DEHR33F182KA3B	3150	16.0	6.0	7.5	0.6	A3	100
R	2200	±10%		DEHR33F222KA3B	3150	17.0	6.0	7.5	0.6	A3	100
R	2700	±10%		DEHR33F272KA4B	3150	19.0	6.0	10.0	0.6	A4	50

Reference only

·Straight short type  
(Lead code:D\*)

·Vertical crimp short type  
(Lead code:B\*)

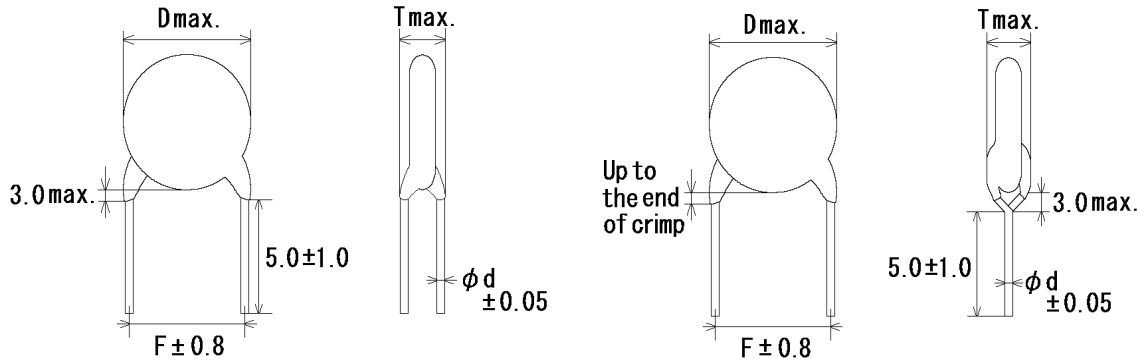

Note) The mark '\*' of lead code differ from lead spacing(F) and lead diameter(d). Please see the following list about details.

Unit : mm

T.C.	Cap. (pF)	Cap. tol.	Customer Part Number	Murata Part Number	DC Rated Volt. (V)	Dimension (mm)				Lead Code	Pack qty. (pcs)
						D	T	F	d		
R	220	±10%		DEHR33D221KD3B	2000	7.0	5.0	7.5	0.6	D3	500
R	270	±10%		DEHR33D271KD3B	2000	7.0	5.0	7.5	0.6	D3	500
R	330	±10%		DEHR33D331KB3B	2000	8.0	5.0	7.5	0.6	B3	500
R	390	±10%		DEHR33D391KB3B	2000	8.0	5.0	7.5	0.6	B3	500
R	470	±10%		DEHR33D471KB3B	2000	9.0	5.0	7.5	0.6	B3	500
R	560	±10%		DEHR33D561KB3B	2000	9.0	5.0	7.5	0.6	B3	500
R	680	±10%		DEHR33D681KB3B	2000	10.0	5.0	7.5	0.6	B3	500
R	820	±10%		DEHR33D821KB3B	2000	11.0	5.0	7.5	0.6	B3	500
R	1000	±10%		DEHR33D102KB3B	2000	12.0	5.0	7.5	0.6	B3	250
R	1200	±10%		DEHR33D122KB3B	2000	12.0	5.0	7.5	0.6	B3	250
R	1500	±10%		DEHR33D152KB3B	2000	12.0	5.0	7.5	0.6	B3	250
R	1800	±10%		DEHR33D182KB3B	2000	14.0	5.0	7.5	0.6	B3	250
R	2200	±10%		DEHR33D222KB3B	2000	15.0	5.0	7.5	0.6	B3	200
R	2700	±10%		DEHR33D272KB3B	2000	17.0	5.0	7.5	0.6	B3	200
R	3300	±10%		DEHR33D332KB4B	2000	19.0	5.0	10.0	0.6	B4	100
R	3900	±10%		DEHR33D392KB4B	2000	20.0	5.0	10.0	0.6	B4	100
R	4700	±10%		DEHR33D472KB4B	2000	21.0	5.0	10.0	0.6	B4	100
R	150	±10%		DEHR33F151KD3B	3150	7.0	6.0	7.5	0.6	D3	500
R	180	±10%		DEHR33F181KD3B	3150	7.0	6.0	7.5	0.6	D3	500
R	220	±10%		DEHR33F221KD3B	3150	7.0	6.0	7.5	0.6	D3	500
R	270	±10%		DEHR33F271KD3B	3150	7.0	6.0	7.5	0.6	D3	500
R	330	±10%		DEHR33F331KB3B	3150	8.0	6.0	7.5	0.6	B3	500
R	390	±10%		DEHR33F391KB3B	3150	9.0	6.0	7.5	0.6	B3	500
R	470	±10%		DEHR33F471KB3B	3150	10.0	6.0	7.5	0.6	B3	500
R	560	±10%		DEHR33F561KB3B	3150	10.0	6.0	7.5	0.6	B3	500
R	680	±10%		DEHR33F681KB3B	3150	11.0	6.0	7.5	0.6	B3	500
R	820	±10%		DEHR33F821KB3B	3150	12.0	6.0	7.5	0.6	B3	250

Reference only

-Vertical crimp short type  
(Lead code: B\*)

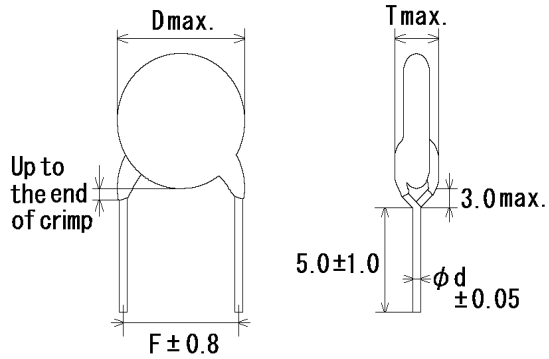

Note) The mark '\*' of lead code differ from lead spacing(F) and lead diameter(d).  
Please see the following list about details.

Unit : mm

T.C.	Cap. (pF)	Cap. tol.	Customer Part Number	Murata Part Number	DC Rated Volt. (V)	Dimension (mm)				Lead Code	Pack qty. (pcs)
						D	T	F	d		
R	1000	±10%		DEHR33F102KB3B	3150	13.0	6.0	7.5	0.6	B3	250
R	1200	±10%		DEHR33F122KB3B	3150	14.0	6.0	7.5	0.6	B3	250
R	1500	±10%		DEHR33F152KB3B	3150	15.0	6.0	7.5	0.6	B3	200
R	1800	±10%		DEHR33F182KB3B	3150	16.0	6.0	7.5	0.6	B3	200
R	2200	±10%		DEHR33F222KB3B	3150	17.0	6.0	7.5	0.6	B3	200
R	2700	±10%		DEHR33F272KB4B	3150	19.0	6.0	10.0	0.6	B4	100

## Reference only

·Straight taping type  
(Lead code:P\*)

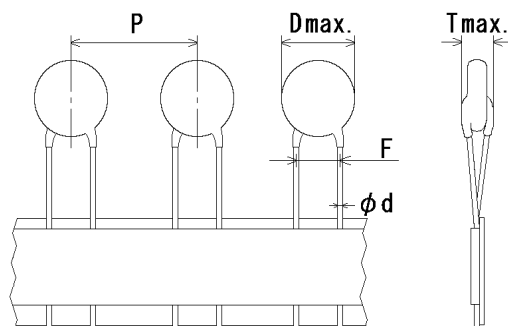

·Vertical crimp taping type  
(Lead code:N\*)

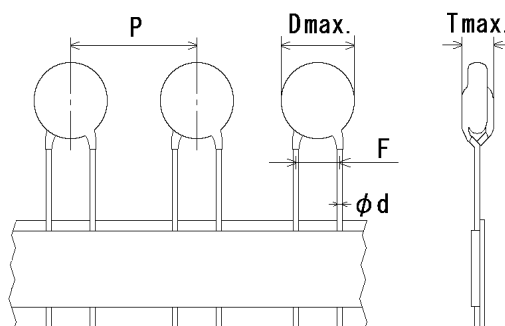

Note) The mark '\*' of lead code differ from lead spacing(F),  
lead diameter(d) and pitch of component(P).  
Please see the following list or taping specification about details.

Unit : mm

T.C.	Cap. (pF)	Cap. tol.	Customer Part Number	Murata Part Number	DC Rated volt. (V)	Dimension (mm)					Lead code	Pack qty. (pcs)
						D	T	F	d	P		
R	220	±10%		DEHR33D221KP3A	2000	7.0	5.0	7.5	0.6	15.0	P3	900
R	270	±10%		DEHR33D271KP3A	2000	7.0	5.0	7.5	0.6	15.0	P3	900
R	330	±10%		DEHR33D331KN3A	2000	8.0	5.0	7.5	0.6	15.0	N3	900
R	390	±10%		DEHR33D391KN3A	2000	8.0	5.0	7.5	0.6	15.0	N3	900
R	470	±10%		DEHR33D471KN3A	2000	9.0	5.0	7.5	0.6	15.0	N3	900
R	560	±10%		DEHR33D561KN3A	2000	9.0	5.0	7.5	0.6	15.0	N3	900
R	680	±10%		DEHR33D681KN3A	2000	10.0	5.0	7.5	0.6	15.0	N3	900
R	820	±10%		DEHR33D821KN3A	2000	11.0	5.0	7.5	0.6	15.0	N3	900
R	1000	±10%		DEHR33D102KN3A	2000	12.0	5.0	7.5	0.6	15.0	N3	900
R	1200	±10%		DEHR33D122KN3A	2000	12.0	5.0	7.5	0.6	15.0	N3	900
R	1500	±10%		DEHR33D152KN3A	2000	12.0	5.0	7.5	0.6	15.0	N3	900
R	1800	±10%		DEHR33D182KN7A	2000	14.0	5.0	7.5	0.6	30.0	N7	500
R	2200	±10%		DEHR33D222KN7A	2000	15.0	5.0	7.5	0.6	30.0	N7	500
R	2700	±10%		DEHR33D272KN7A	2000	17.0	5.0	7.5	0.6	30.0	N7	500
R	150	±10%		DEHR33F151KP3A	3150	7.0	6.0	7.5	0.6	15.0	P3	900
R	180	±10%		DEHR33F181KP3A	3150	7.0	6.0	7.5	0.6	15.0	P3	900
R	220	±10%		DEHR33F221KP3A	3150	7.0	6.0	7.5	0.6	15.0	P3	900
R	270	±10%		DEHR33F271KP3A	3150	7.0	6.0	7.5	0.6	15.0	P3	900
R	330	±10%		DEHR33F331KN3A	3150	8.0	6.0	7.5	0.6	15.0	N3	900
R	390	±10%		DEHR33F391KN3A	3150	9.0	6.0	7.5	0.6	15.0	N3	900
R	470	±10%		DEHR33F471KN3A	3150	10.0	6.0	7.5	0.6	15.0	N3	900
R	560	±10%		DEHR33F561KN3A	3150	10.0	6.0	7.5	0.6	15.0	N3	900
R	680	±10%		DEHR33F681KN3A	3150	11.0	6.0	7.5	0.6	15.0	N3	900
R	820	±10%		DEHR33F821KN3A	3150	12.0	6.0	7.5	0.6	15.0	N3	900
R	1000	±10%		DEHR33F102KN3A	3150	13.0	6.0	7.5	0.6	15.0	N3	900
R	1200	±10%		DEHR33F122KN7A	3150	14.0	6.0	7.5	0.6	30.0	N7	500
R	1500	±10%		DEHR33F152KN7A	3150	15.0	6.0	7.5	0.6	30.0	N7	500

Reference only

·Vartical crimp tapping type  
(Lead code:N\*)

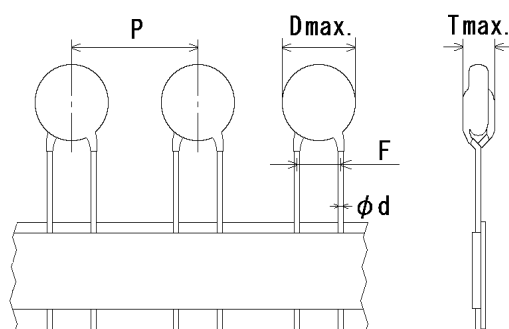

Note) The mark '\*' of lead code differ from lead spacing(F),  
lead diameter(d) and pitch of component(P).  
Please see the following list or taping specification about details.

Unit : mm

T.C.	Cap. (pF)	Cap. tol.	Customer Part Number	Murata Part Number	DC Rated volt. (V)	Dimension (mm)					Lead code	Pack qty. (pcs)
						D	T	F	d	P		
R	1800	±10%		DEHR33F182KN7A	3150	16.0	6.0	7.5	0.6	30.0	N7	500
R	2200	±10%		DEHR33F222KN7A	3150	17.0	6.0	7.5	0.6	30.0	N7	500

## Reference only

5. Specification and test methods												
No.	Item	Specification	Test method									
1	Appearance and dimensions	No marked defect on appearance form and dimensions. Please refer to [Part number list].	The capacitor should be inspected by naked eyes for visible evidence of defect. Dimensions should be measured with slide calipers.									
2	Marking	To be easily legible.	The capacitor should be inspected by naked eyes.									
3	Dielectric strength	Between lead wires No failure.	The capacitor should not be damaged when DC voltage of 200% of the rated voltage are applied between the lead wires for 1 to 5 s. (Charge/Discharge current ≤ 50mA.)									
		Body insulation No failure.	The capacitor is placed in the container with metal balls of diameter 1mm so that each lead wire, shortcircuited, is kept about 2mm off the balls as shown in the figure, and AC1 250V (r.m.s.) <50/60Hz> is applied for 1 to 5 s between capacitor lead wires and small metals. (Charge/Discharge current ≤ 50mA.)									
4	Insulation Resistance (I.R.)	Between lead wires 10 000MΩ min.	The insulation resistance should be measured with DC500±50V within 60±5 s of charging.									
5	Capacitance	Within specified tolerance.	The capacitance should be measured at 20°C with 1±0.2kHz and AC5V(r.m.s.) max..									
6	Dissipation Factor (D.F.)	0.2% max.	The dissipation factor should be measured at 20°C with 1±0.2kHz and AC5V(r.m.s.) max..									
7	Temperature characteristic	<table border="1" style="margin-left: auto; margin-right: auto;"> <thead> <tr> <th rowspan="2">T.C.</th> <th colspan="2">Temp. char.</th> </tr> <tr> <th>-25 to +85°C</th> <th>+85 to +125°C</th> </tr> </thead> <tbody> <tr> <td>R</td> <td>within±15%</td> <td>Within+15/-30%</td> </tr> </tbody> </table>	T.C.	Temp. char.		-25 to +85°C	+85 to +125°C	R	within±15%	Within+15/-30%	The capacitance measurement should be made at each step specified in Table.	
		T.C.		Temp. char.								
-25 to +85°C	+85 to +125°C											
R	within±15%	Within+15/-30%										
<p>Pre-treatment : Capacitor should be stored at 125±3°C for 1 h, then placed at *room condition for 24±2 h before measurements.</p> <table border="1" style="margin-left: auto; margin-right: auto;"> <thead> <tr> <th>Step</th> <th>1</th> <th>2</th> <th>3</th> <th>4</th> <th>5</th> </tr> </thead> <tbody> <tr> <td>Temp.(°C)</td> <td>20±2</td> <td>-25±3</td> <td>20±2</td> <td>125±2</td> <td>20±2</td> </tr> </tbody> </table>	Step	1	2	3	4	5	Temp.(°C)	20±2	-25±3	20±2	125±2	20±2
Step	1	2	3	4	5							
Temp.(°C)	20±2	-25±3	20±2	125±2	20±2							
8	Strength of lead	Pull Lead wire should not cut off. Capacitor should not be broken.	As shown in the figure at right, fix the body of the capacitor and apply a tensile weight gradually to each lead wire in the radial direction of the capacitor up to 10N and keep it for 10±1 s.									
		Bending	Each lead wire should be subjected to 5N of weight and bent 90° at the point of egress, in one direction, then returned to its original position and bent 90° in the opposite direction at the rate of one bend in 2 to 3 s.									
9	Vibration resistance	Appearance	The capacitor should be firmly soldered to the supporting lead wire and vibrated at a frequency range of 10 to 55Hz, 1.5mm in total amplitude, with about a 1min rate of vibration change from 10Hz to 55Hz and back to 10Hz. Apply for a total of 6 h; 2 h each in 3 mutually perpendicular directions.									
		Capacitance										
		D.F.										
10	Solderability of leads	Lead wire should be soldered with uniformly coated on the axial direction over 3/4 of the circumferential direction.	The lead wire of a capacitor should be dipped into a ethanol solution of 25wt% rosin and then into molten solder for 2±0.5 s. In both cases the depth of dipping is up to about 1.5 to 2mm from the root of lead wires. Temp. of solder : 245±5°C Lead Free Solder (Sn-3Ag-0.5Cu) 235±5°C H63 Eutectic Solder									

\* "room condition" Temperature: 15 to 35°C, Relative humidity: 45 to 75%, Atmospheric pressure: 86 to 106kPa

## Reference only

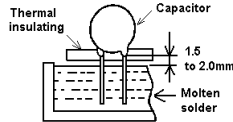
No.	Item	Specification	Test method	
11	Soldering effect (Non-preheat)	Appearance	The lead wire should be immersed into the melted solder of $350\pm 10^{\circ}\text{C}$ up to about 1.5 to 2.0mm from the main body for $3.5\pm 0.5$ s. Pre-treatment : Capacitor should be stored at $125\pm 3^{\circ}\text{C}$ for 1 h, then placed at *room condition for $24\pm 2$ h before initial measurements. Post-treatment : Capacitor should be stored for $24\pm 2$ h at *room condition.	
		Capacitance change		Within $\pm 10\%$
		Dielectric strength (Between lead wires)		Per item 3.
12	Soldering effect (On-preheat)	Appearance	First the capacitor should be stored at $120+0/-5^{\circ}\text{C}$ for $60+0/-5$ s. Then, as in figure, the lead wires should be immersed solder of $260+0/-5^{\circ}\text{C}$ up to 1.5 to 2.0mm from the root of terminal for $7.5+0/-1$ s.  	
		Capacitance change		Within $\pm 10\%$
		Dielectric strength (Between lead wires)		Per item 3.
13	Humidity (Under steady state)	Appearance	Set the capacitor for $500 +24/-0$ h at $40\pm 2^{\circ}\text{C}$ in 90 to 95% relative humidity. Pre-treatment : Capacitor should be stored at $125\pm 3^{\circ}\text{C}$ for 1 h, then placed at *room condition for $24\pm 2$ h before initial measurements. Post-treatment : Capacitor should be stored for 1 to 2 h at *room condition.	
		Capacitance change		Within $\pm 10\%$
		D.F.		0.4% max.
		I.R.		$1\ 000\text{M}\Omega$ min.
14	Humidity loading	Appearance	Apply the rated voltage for $500 +24/-0$ h at $40\pm 2^{\circ}\text{C}$ in 90 to 95% relative humidity. (Charge/Discharge current $\leq 50\text{mA}$ .) Pre-treatment : Capacitor should be stored at $125\pm 3^{\circ}\text{C}$ for 1 h, then placed at *room condition for $24\pm 2$ h before initial measurements. Post-treatment : Capacitor should be stored for 1 to 2 h at *room condition.	
		Capacitance change		Within $\pm 10\%$
		D.F.		0.6% max.
		I.R.		$1\ 000\text{M}\Omega$ min.
15	Life	Appearance	Apply a DC voltage of 150% of the rated voltage for $1\ 000 +48/-0$ h at $125\pm 2^{\circ}\text{C}$ , and relative humidity of 50% max.. (Charge/Discharge current $\leq 50\text{mA}$ .) Pre-treatment : Capacitor should be stored at $125\pm 3^{\circ}\text{C}$ for 1 h, then placed at *room condition for $24\pm 2$ h before initial measurements. Post-treatment : Capacitor should be stored at $125\pm 3^{\circ}\text{C}$ for 1 h, then placed at *room condition for $24\pm 2$ h.	
		Capacitance change		Within $\pm 10\%$
		D.F.		0.4% max.
		I.R.		$2\ 000\text{M}\Omega$ min.

\* "room condition" Temperature: 15 to  $35^{\circ}\text{C}$ , Relative humidity: 45 to 75%, Atmospheric pressure: 86 to  $106\text{kPa}$

**Reference only**

No.	Item	Specification	Test method															
16	Temperature cycle	Appearance	The capacitor should be subjected to 5 temperature cycles. <Temperature cycle> <table border="1" data-bbox="1023 255 1398 392"> <thead> <tr> <th>Step</th> <th>Temperature(°C)</th> <th>Time</th> </tr> </thead> <tbody> <tr> <td>1</td> <td>-25±3</td> <td>30 min</td> </tr> <tr> <td>2</td> <td>Room Temp.</td> <td>3 min</td> </tr> <tr> <td>3</td> <td>+125±3</td> <td>30 min</td> </tr> <tr> <td>4</td> <td>Room Temp.</td> <td>3 min</td> </tr> </tbody> </table> <p align="right">Cycle time : 5 cycle</p> Pre-treatment : Capacitor should be stored at 125±3°C for 1 h, then placed at *room condition for 24±2 h before initial measurements. Post-treatment : Capacitor should be stored for 24±2 h at *room condition.	Step	Temperature(°C)	Time	1	-25±3	30 min	2	Room Temp.	3 min	3	+125±3	30 min	4	Room Temp.	3 min
		Step		Temperature(°C)	Time													
		1		-25±3	30 min													
		2		Room Temp.	3 min													
		3		+125±3	30 min													
4	Room Temp.	3 min																
Capacitance change	Within ±10%																	
D.F.	0.4% max.																	
I.R.	1 000MΩ min.																	
Dielectric strength (Between lead wires)	Per item 3.																	

\* "room condition" Temperature: 15 to 35°C, Relative humidity: 45 to 75%, Atmospheric pressure: 86 to 106kPa



Reference only

6.Packing specification

- Bulk type (Packing style code : B)

The number of packing =  $\frac{\text{Packing quantity}}{\text{Packing quantity}} \times n$

The size of packing case and packing way

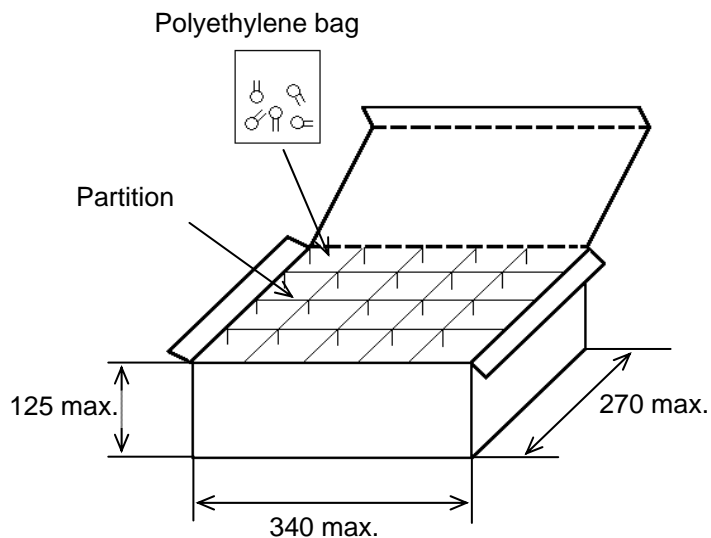

\*1 : Please refer to [Part number list].  
\*2 : Standard n = 20 (bag)

Note)  
The outer package and the number of outer packing be changed by the order getting amount.

Unit : mm

- Ammo pack taping type (Packing style code : A)

- The tape with capacitors is packed zigzag into a case.
- When body of the capacitor is piled on other body under it.
- There should be 3 pitches and over without capacitors in leader and trailer.

The size of packing case and packing way

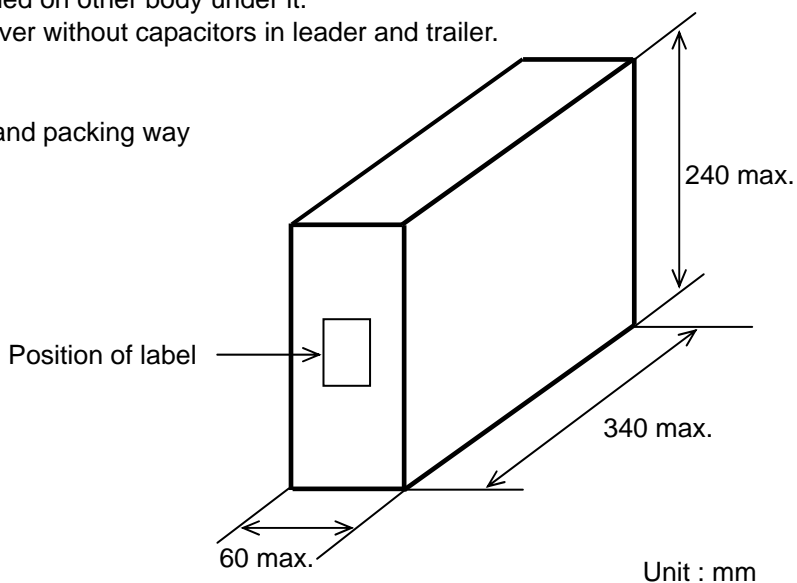

Unit : mm

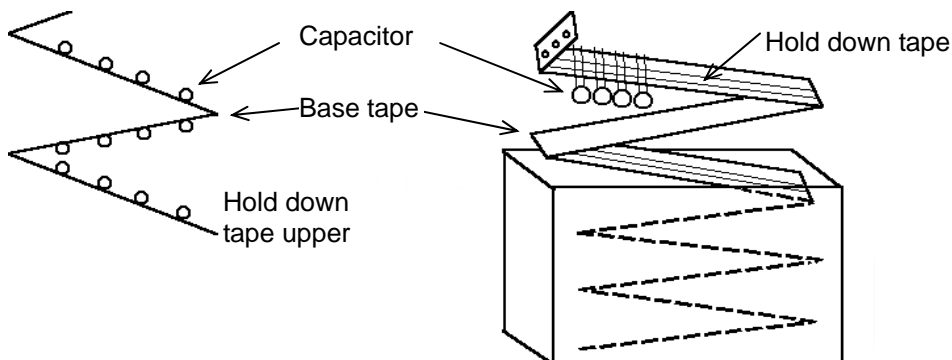

## Reference only

### 7. Taping specification

#### 7-1. Dimension of capacitors on tape

Vertical crimp taping type < Lead code : N3 >

Pitch of component 15.0mm / Lead spacing 7.5mm

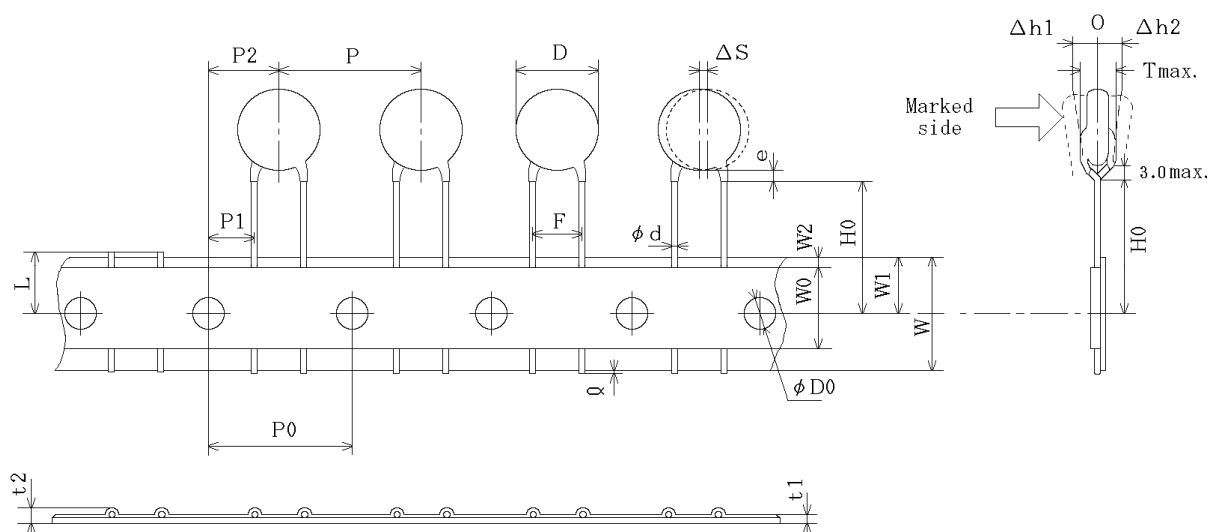

Unit : mm

Item	Code	Dimensions	Remarks
Pitch of component	P	15.0±2.0	
Pitch of sprocket hole	P0	15.0±0.3	
Lead spacing	F	7.5±1.0	
Length from hole center to component center	P2	7.5±1.5	Deviation of progress direction
Length from hole center to lead	P1	3.75±1.0	
Body diameter	D	Please refer to [ Part number list ].	
Deviation along tape, left or right	ΔS	0±2.0	They include deviation by lead bend .
Carrier tape width	W	18.0±0.5	
Position of sprocket hole	W1	9.0±0.5	Deviation of tape width direction
Lead distance between reference and bottom planes	H0	18.0 <sup>±2.0</sup> <sub>0</sub>	
Protrusion length	Q	+0.5~-1.0	
Diameter of sprocket hole	φD0	4.0±0.1	
Lead diameter	φd	0.60±0.05	
Total tape thickness	t1	0.6±0.3	They include hold down tape thickness.
Total thickness, tape and lead wire	t2	1.5 max.	
Deviation across tape, front	Δh1	2.0 max.	
Deviation across tape, rear	Δh2		
Portion to cut in case of defect	L	11.0 <sup>0</sup> ±1.0	
Hold down tape width	W0	11.5 min.	
Hold down tape position	W2	1.5±1.5	
Coating extension on lead	e	Up to the end of crimp	
Body thickness	T	Please refer to [ Part number list ].	

Reference only

Vertical crimp taping type < Lead code : N7 >  
Pitch of component 30.0mm /Lead spacing 7.5mm

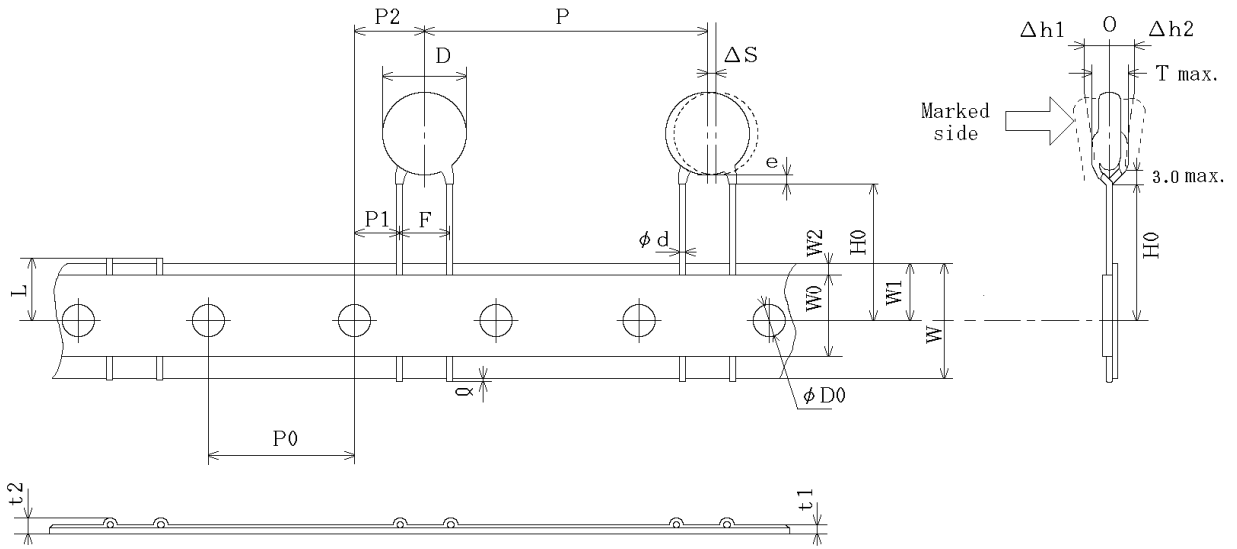

Unit : mm

Item	Code	Dimensions	Remarks
Pitch of component	P	30.0±2.0	
Pitch of sprocket hole	P0	15.0±0.3	
Lead spacing	F	7.5±1.0	
Length from hole center to component center	P2	7.5±1.5	Deviation of progress direction
Length from hole center to lead	P1	3.75±1.0	
Body diameter	D	Please refer to [ Part number list ].	
Deviation along tape, left or right	ΔS	0±2.0	They include deviation by lead bend.
Carrier tape width	W	18.0±0.5	
Position of sprocket hole	W1	9.0±0.5	Deviation of tape width direction
Lead distance between reference and bottom planes	H0	18.0 <sup>+2.0</sup> <sub>0</sub>	
Protrusion length	Q	+0.5~-1.0	
Diameter of sprocket hole	φD0	4.0±0.1	
Lead diameter	φd	0.60±0.05	
Total tape thickness	t1	0.6±0.3	They include hold down tape thickness.
Total thickness, tape and lead wire	t2	1.5 max.	
Deviation across tape, front	Δh1	2.0 max.	
Deviation across tape, rear	Δh2		
Portion to cut in case of defect	L	11.0 <sup>0</sup> ±1.0	
Hold down tape width	W0	11.5 min.	
Hold down tape position	W2	1.5±1.5	
Coating extension on lead	e	Up to the end of crimp	
Body thickness	T	Please refer to [ Part number list ].	

Reference only

Straight tapping type < Lead code : P3 >  
Pitch of component 15.0mm / Lead spacing 7.5mm

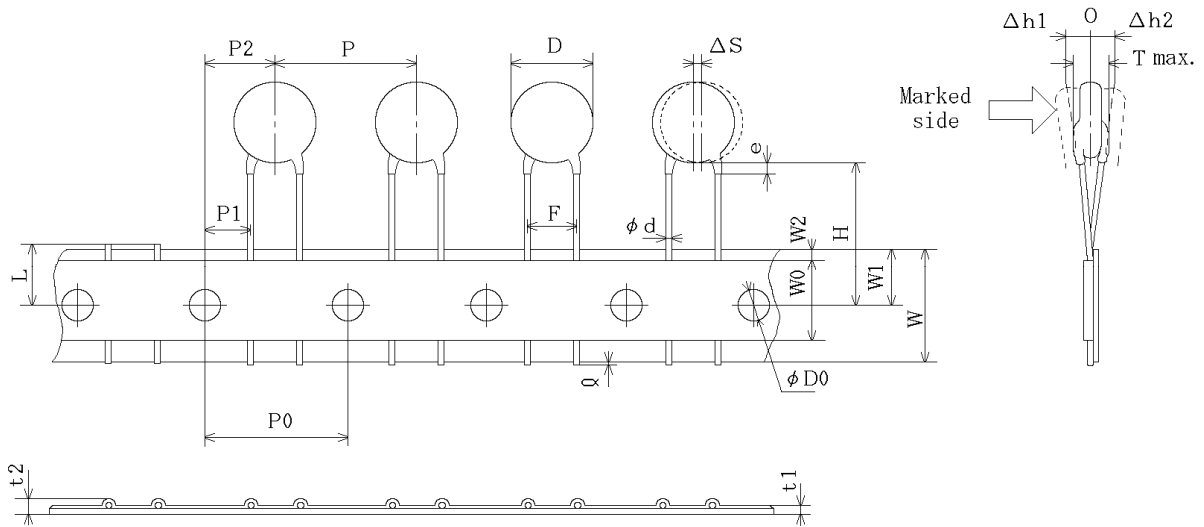

Unit : mm

Item	Code	Dimensions	Remarks
Pitch of component	P	15.0±2.0	
Pitch of sprocket hole	P0	15.0±0.3	
Lead spacing	F	7.5±1.0	
Length from hole center to component center	P2	7.5±1.5	Deviation of progress direction
Length from hole center to lead	P1	3.75±1.0	
Body diameter	D	Please refer to [ Part number list ].	
Deviation along tape, left or right	ΔS	0±2.0	They include deviation by lead bend .
Carrier tape width	W	18.0±0.5	
Position of sprocket hole	W1	9.0±0.5	Deviation of tape width direction
Lead distance between reference and bottom planes	H	20.0± <sup>1.5</sup> <sub>1.0</sub>	
Protrusion length	Q	+0.5~-1.0	
Diameter of sprocket hole	φD0	4.0±0.1	
Lead diameter	φd	0.60±0.05	
Total tape thickness	t1	0.6±0.3	They include hold down tape thickness.
Total thickness, tape and lead wire	t2	1.5 max.	
Deviation across tape, front	Δh1	2.0 max.	
Deviation across tape, rear	Δh2		
Portion to cut in case of defect	L	11.0± <sup>0</sup> <sub>1.0</sub>	
Hold down tape width	W0	11.5 min.	
Hold down tape position	W2	1.5±1.5	
Coating extension on lead	e	3.0 max.	
Body thickness	T	Please refer to [ Part number list ].	

## Reference only

### 7-2. Splicing way of tape

- 1) Adhesive force of tape is over 3N at test condition as below.

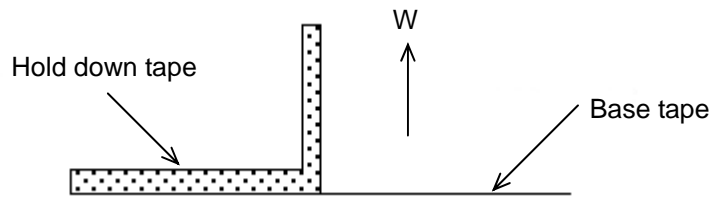

### 2) Splicing of tape

- a) When base tape is spliced

- Base tape should be spliced by cellophane tape.  
(Total tape thickness should be less than 1.05mm.)

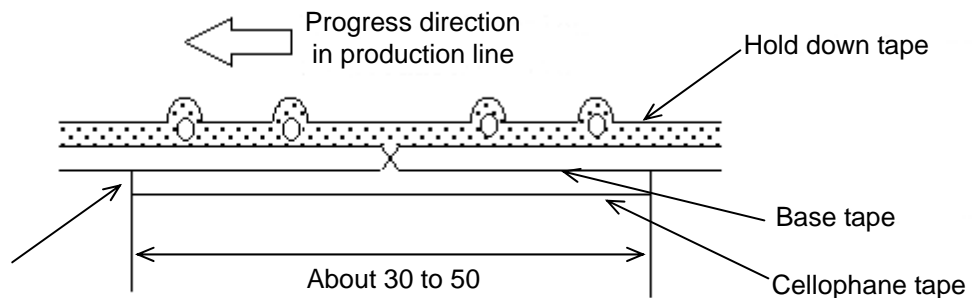

No lifting for the direction of progressing

Unit : mm

- b) When hold down tape is spliced

- Hold down tape should be spliced with overlapping.  
(Total tape thickness should be less than 1.05mm.)

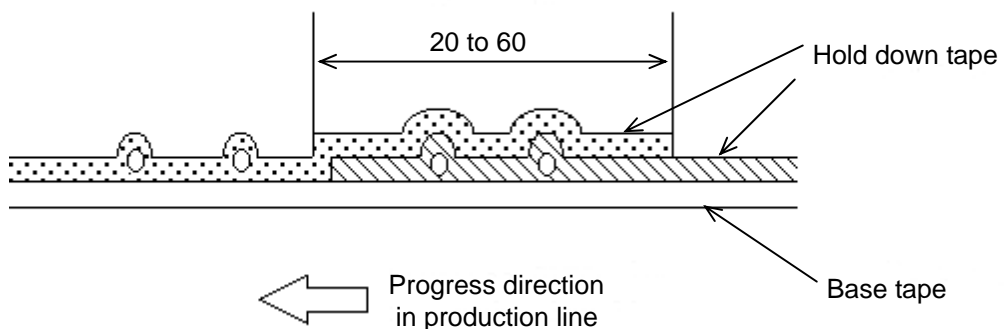

Unit : mm

- c) When both tape are spliced

- Base tape and hold down tape should be spliced with splicing tape.

### 3) Missing components

- There should be no consecutive missing of more than three components.
- The number of missing components should be not more than 0.5% of total components that should be present in a Ammo pack.

EU RoHS  
RoHS指令への対応

This products of the following crresponds to EU RoHS  
当製品は以下の欧州RoHSに対応しています。

(1) RoHS

EU RoHs 2011/65/EC compliance  
2011/65/EC(改正RoHS指令)に対応

maximum concentration values tolerated by weight in homogeneous materials

- ・1000 ppm maximum Lead
- ・1000 ppm maximum Mercury
- ・100 ppm maximum Cadmium
- ・1000 ppm maximum Hexavalent chromium
- ・1000 ppm maximum Polybrominated biphenyls (PBB)
- ・1000 ppm maximum Polybrominated diphenyl ethers (PBDE)

鉛:1000ppm以下

水銀:1000ppm以下

カドミウム:100ppm以下

六価クロム:1000ppm以下

ポリ臭化ビフェニル(PBB):1000ppm以下

ポリ臭化ジフェニルエーテル(PBDE):1000ppm以下