

* R3134K (DFN(PLP)1212-6) and R3134Q (SC-88A) are the discontinued products as of March, 2016.

RICOH

R3134x SERIES

LOW VOLTAGE DETECTOR WITH BUILT-IN DELAY CIRCUIT

NO.EA-209-160316

OUTLINE

R3134x Series are CMOS-based voltage detector ICs with built-in delay circuit, high detector threshold accuracy, and ultra low supply current, which can operate at low voltage.

These ICs can be used as system reset generators, and each of these ICs consists of a voltage reference, a comparator, resistors for setting voltage detector threshold, an output driver transistor, manual reset circuit, and an output delay generator.

Detector threshold is fixed internally with high accuracy and requires no adjustment. When a supply voltage crosses a setting detector threshold voltage from a high value to a lower value, this IC generates reset signal.

R3134x Series output "L" at its detect.

Since each of R3134x Series embeds an output delay generator, during a setting 240ms delay time, which is fixed in the IC, this IC keeps the reset condition after they are released. Released conditions will be kept for the delay time from when a supply voltage crosses a setting detector threshold voltage from a low value to a higher value, or from when the manual reset signal is released.

Two output types, Nch open drain type and CMOS type, are available.

Since the packages for these ICs are DFN(PLP)1212-6, SOT-23-5, and SC-88A, high density mounting of the ICs on board is possible.

FEATURES

- Supply Current Typ. 0.8 μ A (R3134x27Ex, V_{DD}=3.0V)
- Operating Voltage Range 0.75V to 6.0V (T_{opt}=25°C)
- Detector Threshold Range 1.0V to 5.0V (0.1V steps)
Further, 2.32V, 2.63V, 2.93V, 3.08V, 4.38V, and 4.63V can be provided as standard.
- Detector Threshold Accuracy \pm 1.8%
- Temperature-Drift Coefficient of Detector Threshold Typ. \pm 100ppm/°C
- Built-in Delay Time Circuit Typ. 240ms
- Output Delay Time Accuracy \pm 15%
- Output Types Nch Open Drain and CMOS
- Packages DFN(PLP)1212-6, SC-88A, SOT-23-5

APPLICATIONS

- CPU and Logic Circuit Reset
- Battery Checker
- Window Comparator
- Wave Shaping Circuit
- Battery Back-up Circuit
- Power Failure Detector

R3134x

BLOCK DIAGRAMS

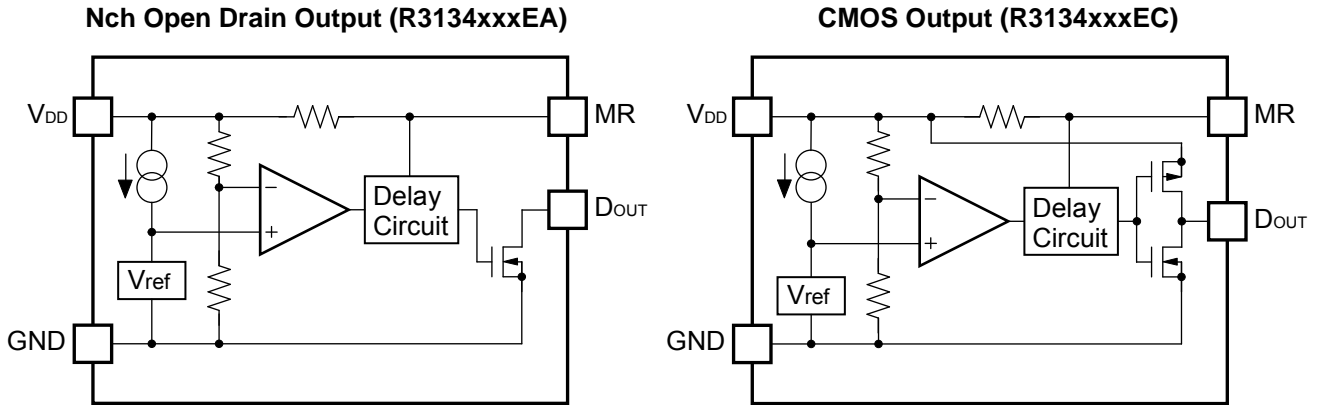

SELECTION GUIDE

The package type, the detector threshold, the output type and the taping type for the ICs can be selected at the users' request.

Product Name	Package	Quantity per Reel	Pb Free	Halogen Free
R3134KxxE*(y)-TR	DFN(PLP)1212-6	5,000 pcs	Yes	Yes
R3134QxxE*(y)-TR-FE	SC-88A	3,000 pcs	Yes	Yes
R3134NxxE*(y)-TR-FE	SOT-23-5	3,000 pcs	Yes	Yes

xx: The detector threshold can be designated in the range from 1.0V(10) to 5.0V(50) in 0.1V steps.

y: If the detector threshold includes the 3rd digit, indicate the digit of 0.01V.

(Example) If the detector threshold is 2.63V, R3134x26E*3-TR-x

* : Designation of Output Type

(A) Nch Open Drain

(C) CMOS

PIN CONFIGURATIONS

• DFN(PLP)1212-6

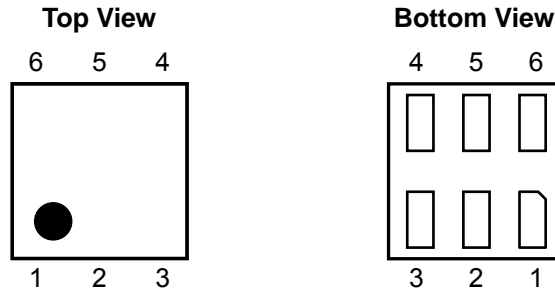

• SC-88A

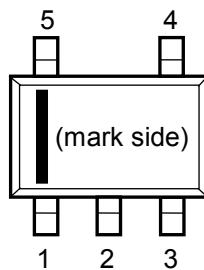

• SOT-23-5

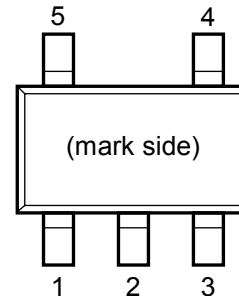

PIN DESCRIPTIONS

• DFN(PLP)1212-6

Pin No.	Symbol	Description
1	V _{DD}	Input Pin
2	NC	No Connection
3	GND	Ground Pin
4	D _{OUT}	Output Pin ("L" at detection)
5	NC	No Connection
6	MR	Manual Reset Input Pin*

• SC-88A

Pin No.	Symbol	Description
1	V _{DD}	Input Pin
2	GND	Ground Pin
3	MR	Manual Reset Input Pin*
4	D _{OUT}	Output Pin ("L" at detection)
5	NC	No Connection

• SOT-23-5

Pin No.	Symbol	Description
1	D _{OUT}	Output Pin ("L" at detection)
2	V _{DD}	Input Pin
3	GND	Ground Pin
4	MR	Manual Reset Input Pin*
5	NC	No Connection

*) MR pin is active at "L" input. Pulled up via 1MΩ (Typ.). If MR pin is not necessary, open this node, or connect it to V_{DD}.

* R3134K (DFN(PLP)1212-6) and R3134Q (SC-88A) are the discontinued products as of March, 2016.

R3134x

ABSOLUTE MAXIMUM RATINGS

Symbol	Item	Rating	Unit
V_{DD}	Supply Voltage	6.5	V
V_{OUT}	Output Voltage (Nch Open Drain Output)	$V_{SS}-0.3$ to 6.5	V
	Output Voltage (CMOS Output)	$V_{SS}-0.3$ to $V_{DD}+0.3$	
V_{MR}	Input Voltage	$V_{SS}-0.3$ to $V_{DD}+0.3$	V
I_{OUT}	Output Current	20	mA
P_D	Power Dissipation (DFN(PLP)1212-6)*	400	mW
	Power Dissipation (SC-88A)*	380	
	Power Dissipation (SOT-23-5)*	420	
T_{opt}	Operating Temperature Range	-40 to 85	°C
T_{stg}	Storage Temperature Range	-55 to 125	°C

*) For Power Dissipation, please refer to PACKAGE INFORMATION.

ABSOLUTE MAXIMUM RATINGS

Electronic and mechanical stress momentarily exceeded absolute maximum ratings may cause the permanent damages and may degrade the life time and safety for both device and system using the device in the field. The functional operation at or over these absolute maximum ratings is not assured.

ELECTRICAL CHARACTERISTICS

• R3134x

The specification in is checked and guaranteed by design engineering at $-40^{\circ}\text{C} \leq T_{\text{opt}} \leq 85^{\circ}\text{C}$.

$T_{\text{opt}}=25^{\circ}\text{C}$

Symbol	Item	Conditions	Min.	Typ.	Max.	Unit	
V_{DET}	Detector Threshold		$V_{\text{DET}} \times 0.982$		$V_{\text{DET}} \times 1.018$	V	
I_{SS1}	Supply Current1	$V_{\text{DD}}=V_{\text{DET}}-0.1\text{V}$, $I_{\text{OUT}}=0\text{A}$			2.0	μA	
I_{SS2}	Supply Current2	$V_{\text{DD}}=V_{\text{DET}}+0.1\text{V}$, $I_{\text{OUT}}=0\text{A}$			2.0	μA	
I_{SS3}	Supply Current3	$V_{\text{DD}}=6\text{V}$, $I_{\text{OUT}}=0\text{A}$	$V_{\text{DET}} < 1.6\text{V}$			3.6	μA
			$1.6 \leq V_{\text{DET}} < 2.7\text{V}$			3.0	
			$2.7\text{V} \leq V_{\text{DET}}$			2.5	
V_{DD}	Operating Voltage	$T_{\text{opt}}=25^{\circ}\text{C}$	0.75		6.00	V	
		$-40^{\circ}\text{C} \leq T_{\text{opt}} \leq 85^{\circ}\text{C}$	<input type="checkbox"/> 0.85		<input type="checkbox"/> 6.00		
V_{OH}	"H" Output Voltage	Refer to the following table					
V_{OL}	"L" Output Voltage	Refer to the following table					
V_{IH}	MR pin "H" Input Voltage	$V_{\text{DD}} \geq V_{\text{DET}}+0.1\text{V}$	$0.75 \times V_{\text{DD}}$			V	
V_{IL}	MR pin "L" Input Voltage	$V_{\text{DD}} \geq V_{\text{DET}}+0.1\text{V}$			$0.2 \times V_{\text{DD}}$	V	
R_{MR}	MR pin pull-up Resistance	$T_{\text{opt}}=25^{\circ}\text{C}$	0.5	1.0	4.0	$\text{M}\Omega$	
$\frac{\Delta V_{\text{DET}}}{\Delta T_{\text{opt}}}$	Detector Threshold Temperature Coefficient	$-40^{\circ}\text{C} \leq T_{\text{opt}} \leq 85^{\circ}\text{C}$		± 100		$\frac{\text{ppm}}{^{\circ}\text{C}}$	
t_{reset}	Output Delay Time for detect *	$V_{\text{DD}}=V_{\text{DET}} \rightarrow V_{\text{DET}}-0.1\text{V}$		15		μs	
t_{delay}	Output Delay Time for release	$V_{\text{DD}}=0.8\text{V} \rightarrow V_{\text{DET}}+1.0$	204	240	276	ms	

*) Guaranteed by design, not mass production tested.

RECOMMENDED OPERATING CONDITIONS (ELECTRICAL CHARACTERISTICS)

All of electronic equipment should be designed that the mounted semiconductor devices operate within the recommended operating conditions. The semiconductor devices cannot operate normally over the recommended operating conditions, even if when they are used over such conditions by momentary electronic noise or surge. And the semiconductor devices may receive serious damage when they continue to operate over the recommended operating conditions.

* R3134K (DFN(PLP)1212-6) and R3134Q (SC-88A) are the discontinued products as of March, 2016.

R3134x

• "H" Output Voltage (V_{OH}) table

$T_{opt}=25^{\circ}\text{C}$

Products	Detector Threshold V_{DET} (V)	"H" Output Voltage V_{OH} (V)			
		Conditions	Min.	Typ.	Max.
R3134xxxEC	$V_{DET} < 1.2\text{V}$	$V_{DD}=V_{DET}+0.1\text{V}$, $I_{OH}=50\mu\text{A}$	0.8 \times V_{DD}		
	$1.2\text{V} \leq V_{DET} < 2.0\text{V}$	$V_{DD}=V_{DET}+0.1\text{V}$, $I_{OH}=150\mu\text{A}$			
	$2.0\text{V} \leq V_{DET} < 3.1\text{V}$	$V_{DD}=V_{DET}+0.1\text{V}$, $I_{OH}=500\mu\text{A}$			
	$3.1\text{V} \leq V_{DET}$	$V_{DD}=V_{DET}+0.1\text{V}$, $I_{OH}=800\mu\text{A}$			

V_{DET} is a set value.

• "L" Output Voltage (V_{OL}) table

$T_{opt}=25^{\circ}\text{C}$

Products	Detector Threshold V_{DET} (V)	"L" Output Voltage V_{OL} (V)			
		Conditions	Min.	Typ.	Max.
R3134xxxEx	$V_{DET} < 1.2\text{V}$	$V_{DD}=V_{DET}-0.1\text{V}$, $I_{OL}=200\mu\text{A}$			0.04
	$1.2\text{V} \leq V_{DET} < 2.0\text{V}$	$V_{DD}=V_{DET}-0.1\text{V}$, $I_{OL}=750\mu\text{A}$			0.06
	$2.0\text{V} \leq V_{DET} < 3.1\text{V}$	$V_{DD}=V_{DET}-0.1\text{V}$, $I_{OL}=1.2\text{mA}$			0.05
	$3.1\text{V} \leq V_{DET}$	$V_{DD}=V_{DET}-0.1\text{V}$, $I_{OL}=3.2\text{mA}$			0.06

V_{DET} is a set value.

* R3134K (DFN(PLP)1212-6) and R3134Q (SC-88A) are the discontinued products as of March, 2016.

R3134x

DETECTOR THRESHOLD SPECIFICATIONS BY PART NUMBER

• R3134x

Part Number	Operating Voltage				Detector Threshold			Supply Current 1			
	VDD [V]				VDET [V]			ISS1 [μA]			
	Conditions	Min.	Conditions	Min.	Min.	Typ.	Max.	Conditions	Typ.	Max.	
R3134x23Ex2	Topt=25°C	0.75	-40°C ≤ Topt ≤ 85°C	0.85	2.278	2.320	2.362	VDD=VDET-0.1V IOUT=0A	0.8	2.0	
R3134x26Ex3					2.583	2.630	2.677				
R3134x29Ex3					2.877	2.930	2.983				
R3134x30Ex8					3.025	3.080	3.135				
R3134x43Ex8					4.301	4.380	4.459				
R3134x46Ex3					4.547	4.630	4.713				
R3134x10Ex	Topt=25°C	0.75	-40°C ≤ Topt ≤ 85°C	0.85	0.982	1.000	1.018	VDD=VDET-0.1V IOUT=0A	0.8	2.0	
R3134x11Ex					1.080	1.100	1.120				
R3134x12Ex					1.178	1.200	1.222				
R3134x13Ex					1.277	1.300	1.323				
R3134x14Ex					1.375	1.400	1.425				
R3134x15Ex					1.473	1.500	1.527				
R3134x16Ex					1.571	1.600	1.629				
R3134x17Ex					1.669	1.700	1.731				
R3134x18Ex					1.768	1.800	1.832				
R3134x19Ex					1.866	1.900	1.934				
R3134x20Ex					1.964	2.000	2.036				
R3134x21Ex					2.062	2.100	2.138				
R3134x22Ex					2.160	2.200	2.240				
R3134x23Ex					2.259	2.300	2.341				
R3134x24Ex					2.357	2.400	2.443				
R3134x25Ex					2.455	2.500	2.545				
R3134x26Ex					2.553	2.600	2.647				
R3134x27Ex					2.651	2.700	2.749				
R3134x28Ex					2.750	2.800	2.850				
R3134x29Ex					2.848	2.900	2.952				
R3134x30Ex					2.946	3.000	3.054		VDD=VDET-0.1V IOUT=0A		0.9
R3134x31Ex					3.044	3.100	3.156				
R3134x32Ex					3.142	3.200	3.258				
R3134x33Ex					3.241	3.300	3.359				
R3134x34Ex					3.339	3.400	3.461				
R3134x35Ex					3.437	3.500	3.563				
R3134x36Ex					3.535	3.600	3.665				
R3134x37Ex					3.633	3.700	3.767				
R3134x38Ex					3.732	3.800	3.868				
R3134x39Ex					3.830	3.900	3.970				
R3134x40Ex	3.928	4.000	4.072								
R3134x41Ex	4.026	4.100	4.174								
R3134x42Ex	4.124	4.200	4.276								
R3134x43Ex	4.223	4.300	4.377								
R3134x44Ex	4.321	4.400	4.479								
R3134x45Ex	4.419	4.500	4.581								
R3134x46Ex	4.517	4.600	4.683								
R3134x47Ex	4.615	4.700	4.785								
R3134x48Ex	4.714	4.800	4.886								
R3134x49Ex	4.812	4.900	4.988								
R3134x50Ex	4.910	5.000	5.090								

* R3134K (DFN(PLP)1212-6) and R3134Q (SC-88A) are the discontinued products as of March, 2016.

R3134x

Supply Current 2			Supply Current 3			"H" Output Voltage	
Iss2 [μ A]			Iss3 [μ A]			Voh [V]	
Conditions	Typ.	Max.	Conditions	Typ.	Max.	Conditions	Min.
VDD=VDET+0.1V IOUT=0A	0.8	2.0	VDD=6.0V IOUT=0A	1.2	3.0	VDD=VDET+0.1V IOH=500 μ A	0.8 \times VDD
				1.0	2.5	VDD=VDET+0.1V IOH=800 μ A	
VDD=VDET+0.1V IOUT=0A	0.8	2.0	VDD=6.0V IOUT=0A	1.4	3.6	VDD=VDET+0.1V IOH=50 μ A	0.8 \times VDD
						VDD=VDET+0.1V IOH=150 μ A	
				1.2	3.0	VDD=VDET+0.1V IOH=500 μ A	
						VDD=VDET+0.1V IOH=800 μ A	
				1.0	2.5	VDD=VDET+0.1V IOH=800 μ A	
						0.8	

* R3134K (DFN(PLP)1212-6) and R3134Q (SC-88A) are the discontinued products as of March, 2016.

R3134x

Part Number	"L" Output Voltage		MR pin "H" Input Voltage		MR pin "L" Input Voltage		MR pin pull-up resistance											
	VoL [V]		VIH [V]		VIL [V]		RMR [MΩ]											
	Conditions	Max.	Conditions	Min.	Conditions	Max.	Conditions	Min.	Typ.	Max.								
R3134x23Ex2	VDD=VDET-0.1V IOL=1.2mA	0.05	VDD ≥ VDET+0.1	0.75× VDD	VDD ≥ VDET+0.1	0.2× VDD	Topt=25°C	0.5	1.0	4.0								
R3134x26Ex3																		
R3134x29Ex3																		
R3134x30Ex8																		
R3134x43Ex8	VDD=VDET-0.1V IOL=3.2mA	0.06	VDD ≥ VDET+0.1	0.75× VDD	VDD ≥ VDET+0.1	0.2× VDD	Topt=25°C	0.5	1.0	4.0								
R3134x46Ex3																		
R3134x10Ex	VDD=VDET-0.1V IOL=200μA	0.04									VDD ≥ VDET+0.1	0.75× VDD	VDD ≥ VDET+0.1	0.2× VDD	Topt=25°C	0.5	1.0	4.0
R3134x11Ex																		
R3134x12Ex	VDD=VDET-0.1V IOL=750μA	0.06	VDD ≥ VDET+0.1	0.75× VDD	VDD ≥ VDET+0.1	0.2× VDD	Topt=25°C	0.5	1.0	4.0								
R3134x13Ex																		
R3134x14Ex																		
R3134x15Ex																		
R3134x16Ex			VDD=VDET-0.1V IOL=1.2mA	0.05	VDD ≥ VDET+0.1	0.75× VDD	VDD ≥ VDET+0.1	0.2× VDD	Topt=25°C	0.5	1.0	4.0						
R3134x17Ex																		
R3134x18Ex																		
R3134x19Ex																		
R3134x20Ex	VDD=VDET-0.1V IOL=1.2mA	0.05			VDD ≥ VDET+0.1	0.75× VDD	VDD ≥ VDET+0.1	0.2× VDD	Topt=25°C	0.5	1.0	4.0						
R3134x21Ex																		
R3134x22Ex																		
R3134x23Ex																		
R3134x24Ex			VDD=VDET-0.1V IOL=3.2mA	0.06	VDD ≥ VDET+0.1	0.75× VDD	VDD ≥ VDET+0.1	0.2× VDD	Topt=25°C	0.5	1.0	4.0						
R3134x25Ex																		
R3134x26Ex																		
R3134x27Ex																		
R3134x28Ex	VDD=VDET-0.1V IOL=3.2mA	0.06			VDD ≥ VDET+0.1	0.75× VDD	VDD ≥ VDET+0.1	0.2× VDD	Topt=25°C	0.5	1.0	4.0						
R3134x29Ex																		
R3134x30Ex																		
R3134x31Ex																		
R3134x32Ex			VDD=VDET-0.1V IOL=3.2mA	0.06	VDD ≥ VDET+0.1	0.75× VDD	VDD ≥ VDET+0.1	0.2× VDD	Topt=25°C	0.5	1.0	4.0						
R3134x33Ex																		
R3134x34Ex																		
R3134x35Ex																		
R3134x36Ex	VDD=VDET-0.1V IOL=3.2mA	0.06			VDD ≥ VDET+0.1	0.75× VDD	VDD ≥ VDET+0.1	0.2× VDD	Topt=25°C	0.5	1.0	4.0						
R3134x37Ex																		
R3134x38Ex																		
R3134x39Ex																		
R3134x40Ex			VDD=VDET-0.1V IOL=3.2mA	0.06	VDD ≥ VDET+0.1	0.75× VDD	VDD ≥ VDET+0.1	0.2× VDD	Topt=25°C	0.5	1.0	4.0						
R3134x41Ex																		
R3134x42Ex																		
R3134x43Ex																		
R3134x44Ex	VDD=VDET-0.1V IOL=3.2mA	0.06			VDD ≥ VDET+0.1	0.75× VDD	VDD ≥ VDET+0.1	0.2× VDD	Topt=25°C	0.5	1.0	4.0						
R3134x45Ex																		
R3134x46Ex																		
R3134x47Ex																		
R3134x48Ex			VDD=VDET-0.1V IOL=3.2mA	0.06	VDD ≥ VDET+0.1	0.75× VDD	VDD ≥ VDET+0.1	0.2× VDD	Topt=25°C	0.5	1.0	4.0						
R3134x49Ex																		
R3134x50Ex																		

* R3134K (DFN(PLP)1212-6) and R3134Q (SC-88A) are the discontinued products as of March, 2016.

R3134x

Output Delay Time for Release				Detector Threshold Temperature Coefficient	
t _{delay} [ms]				$\Delta V_{DET}/\Delta T_{opt}$ [ppm/°C]	
Conditions	Min.	Typ.	Max.	Conditions	Typ.
V _{DD} =0.8V→ V _{DET} +1.0V T _{opt} =25°C	204	240	276	-40°C ≤ T _{opt} ≤ 85°C	±100
V _{DD} =0.8V→ V _{DET} +1.0V T _{opt} =25°C	204	240	276	-40°C ≤ T _{opt} ≤ 85°C	±100

TIMING CHART

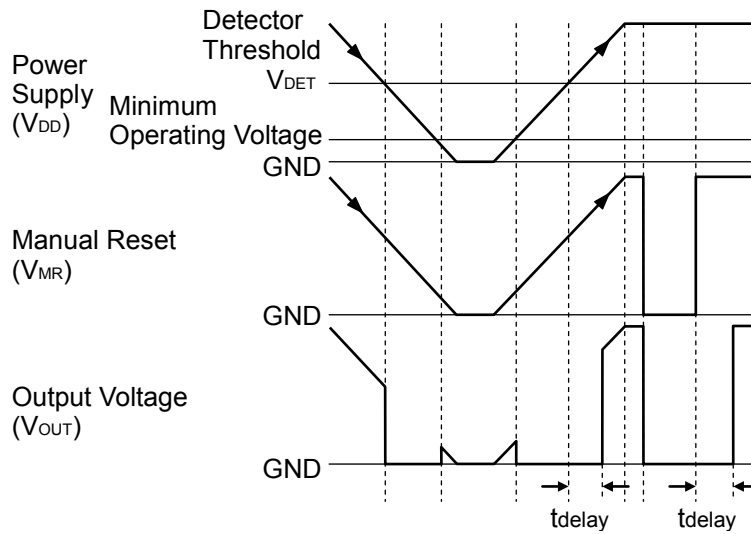

R3134x Operating Diagram

DEFINITION OF OUTPUT DELAY TIME

Output Delay Time (t_{delay}) is specified as follows:

1. In the case of Nch Open Drain Output:

The time interval from rising edge of V_{DD} pulse 0.8V to $V_{DET}+1.0V$ to the time at which the output reaches 2.5V under the condition that the output pin (D_{OUT}) is pulled up to 5V through a 470k Ω resistor.

2. In the case of CMOS Output:

The time interval from rising edge of V_{DD} pulse 0.8V to $V_{DET}+1.0V$ to the time at the output reaches $(V_{DET}+1.0V)/2$.

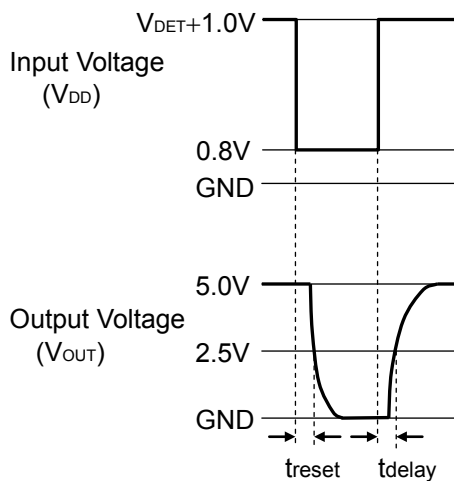

Nch Open Drain Output
(R3134xxxEA)

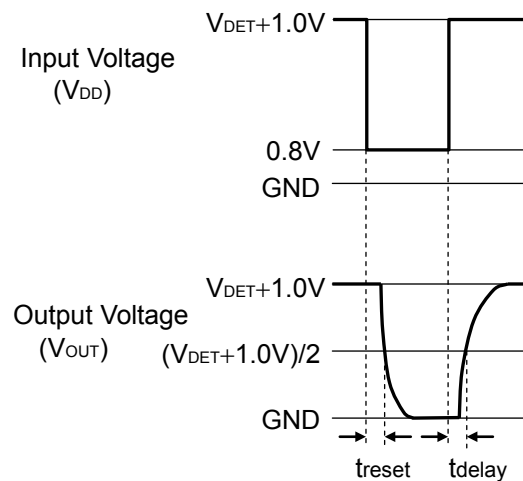

CMOS Output
(R3134xxxEC)

R3134x

OPERATION

• Operation of R3134xxxEA

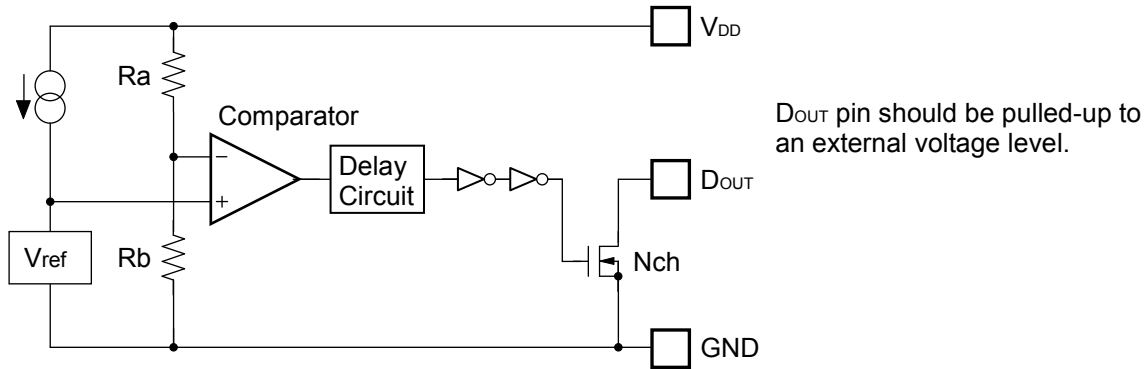

Block Diagram

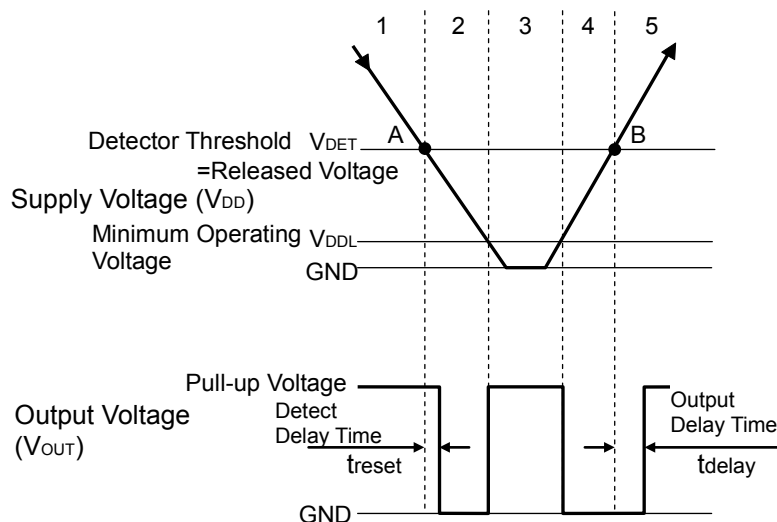

Operation Diagram

• Explanation of operation

Step 1. The output voltage is equal to the pull-up voltage.

Step 2. At Point "A", $V_{ref} \geq V_{DD} \times R_b / (R_a + R_b)$ is true, as a result, the output of comparator is reversed from "L" to "H", therefore the output voltage becomes the GND level. The voltage level of Point A means a detector threshold voltage (V_{DET}).

Step 3. When the supply voltage is lower than the minimum operating voltage, the operation of the output transistor becomes indefinite. The output voltage is equal to the pull-up voltage.

Step 4. The output voltage is equal to the GND level.

Step 5. At Point "B", $V_{ref} \leq V_{DD} \times R_b / (R_a + R_b)$ is true, as a result, the output of comparator is reversed from "H" to "L", then the output voltage is equal to the pull-up voltage. The voltage level of Point B means a released voltage (V_{DET}).

*) There is no hysteresis range between the detector threshold and the released voltage.

• Operation of R3134xxxEC

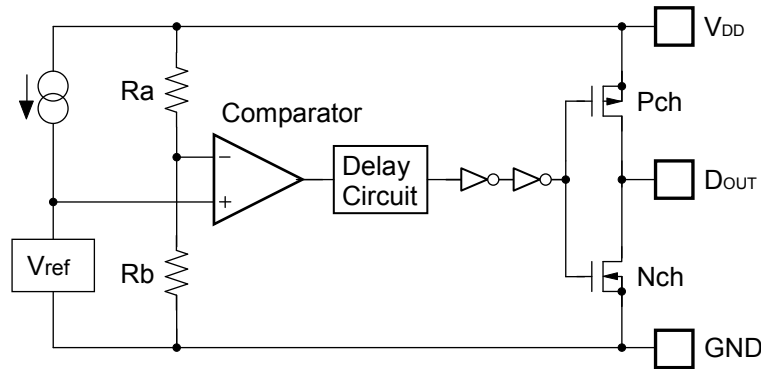

Block Diagram

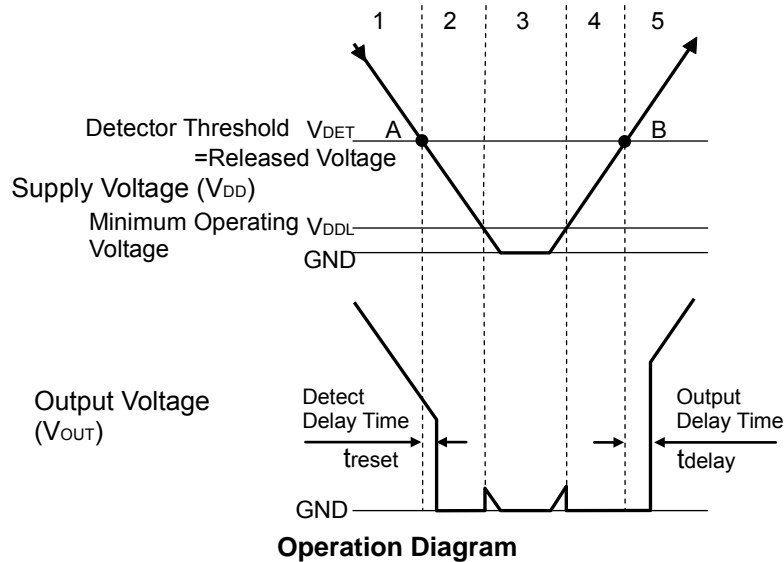

Operation Diagram

• Explanation of operation

Step 1. The output voltage is equal to the supply voltage (V_{DD}).

Step 2. At Point "A", $V_{ref} \geq V_{DD} \times R_b / (R_a + R_b)$ is true, as a result, the output of comparator is reversed from "L" to "H", therefore the output voltage becomes the GND level. The voltage level of Point A means a detector threshold voltage (V_{DET}).

Step 3. When the supply voltage is lower than the minimum operating voltage, the operation of the output transistor becomes indefinite.

Step 4. The output voltage is equal to the GND level.

Step 5. At Point "B", $V_{ref} \leq V_{DD} \times R_b / (R_a + R_b)$ is true, as a result, the output of comparator is reversed from "H" to "L", then the output voltage is equal to the supply voltage (V_{DD}). The voltage level of Point B means a released voltage (V_{DET}).

*) There is no hysteresis range between the detector threshold and the released voltage.

R3134x

Detector Operation vs. glitch input voltage to the V_{DD} pin

When the IC is released and a large pulse (glitch) crosses the detector threshold is forced, the IC may not maintain the released condition. The amplitude of the pulse ($V_{DET}-V_{DDmin}$) and the pulse width the IC can maintain the released level is described in the graph as follows:

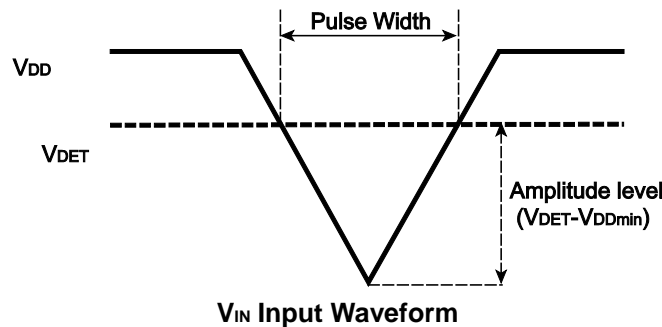
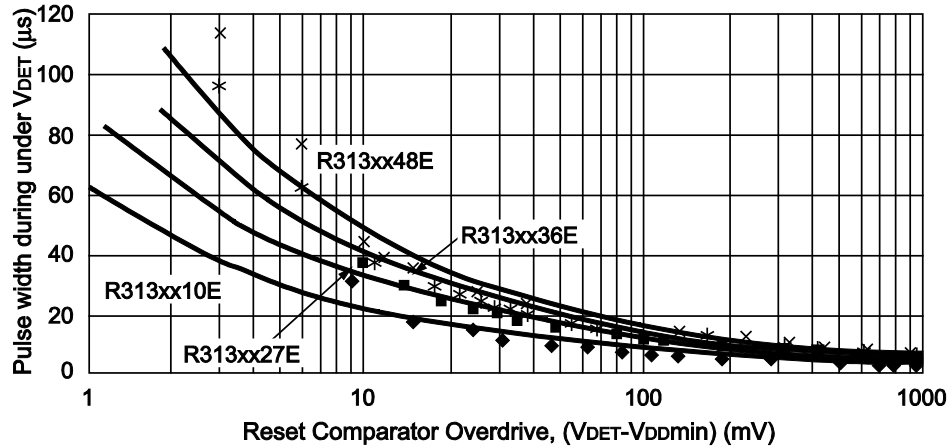

The graph above shows the condition for the maximum transient duration without generating a reset. If the larger amplitude or larger pulse width noise than the graph may be on the V_{DD} , the reset signal may be generated.

TEST CIRCUITS

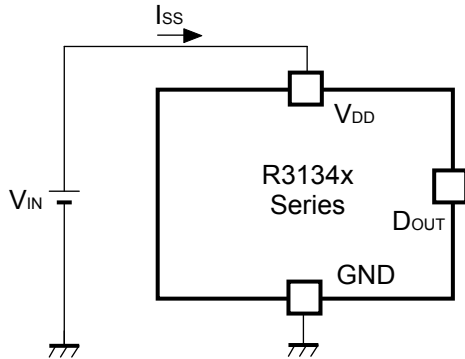

Supply Current Test Circuit

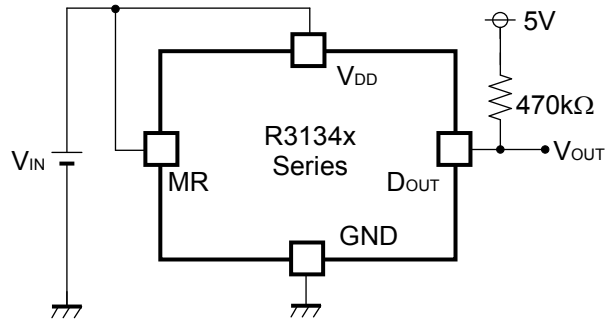

Detector Threshold Test Circuit
(Pull-up circuit is not necessary for CMOS Output type.)

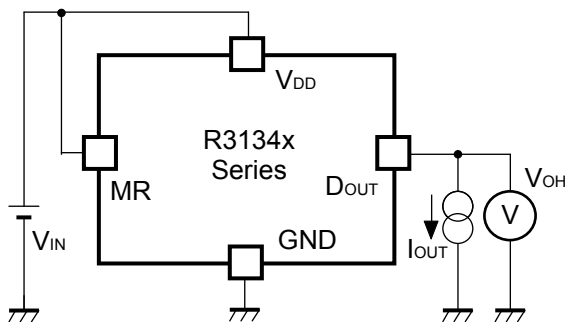

"H" Output Voltage Test Circuit
(CMOS Output Type only)

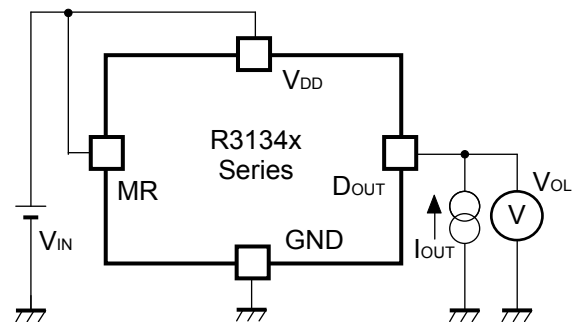

"L" Output Voltage Test Circuit

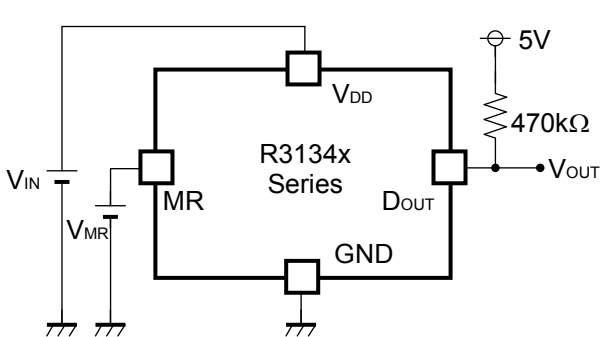

MR pin Input Voltage Test Circuit
(Pull-up circuit is not necessary for CMOS Output type.)

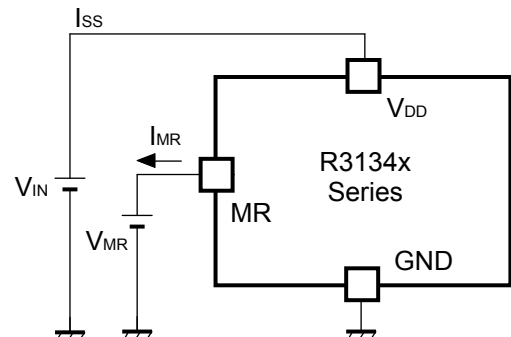

MR pin Pull-up Resistance Test Circuit

* R3134K (DFN(PLP)1212-6) and R3134Q (SC-88A) are the discontinued products as of March, 2016.

R3134x

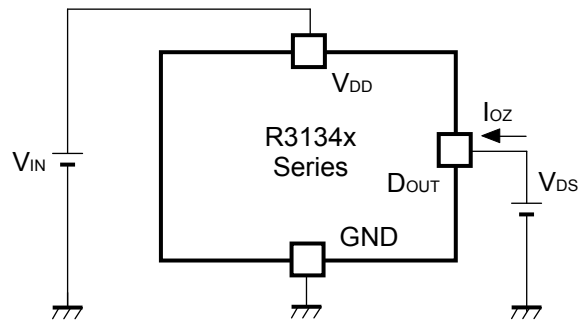

Off Leakage Current Test Circuit

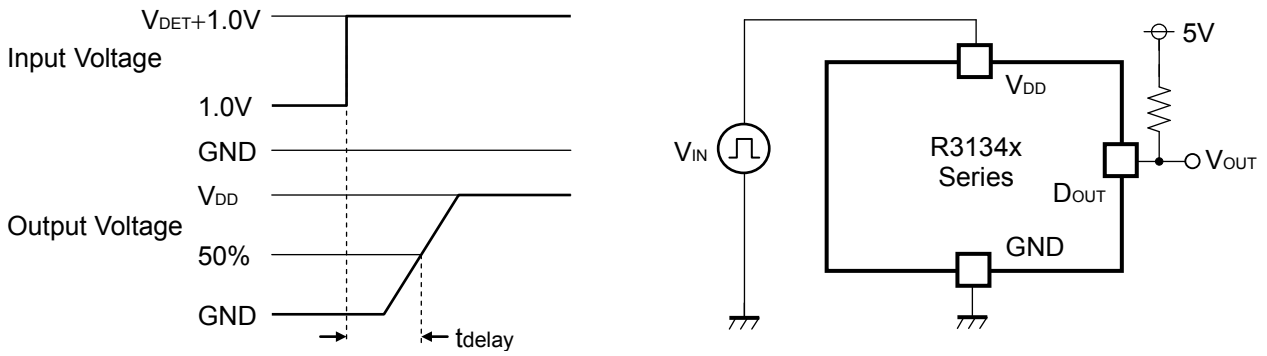

Output Delay Time Test Circuit

(Pull-up circuit is not necessary for CMOS Output type.)

TYPICAL CHARACTERISTICS

1) Supply Current vs. Input Voltage

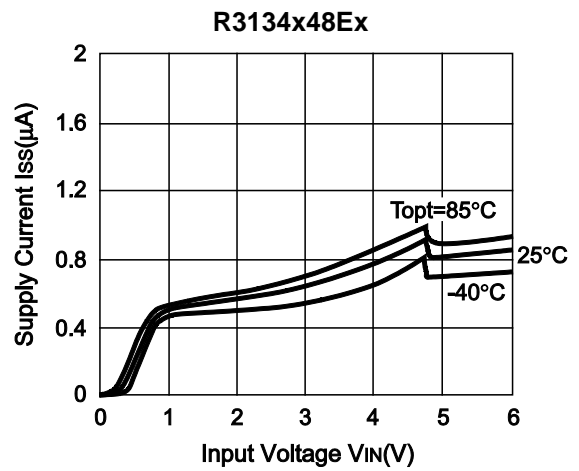
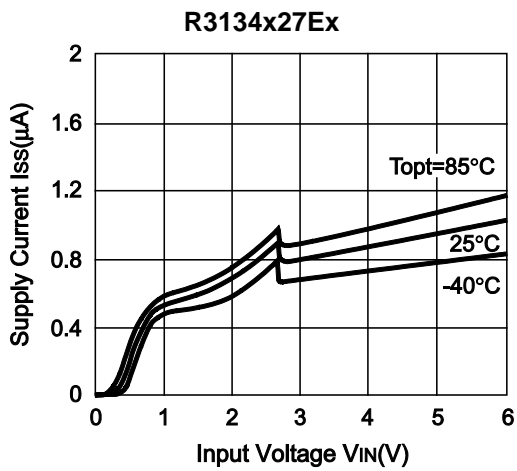
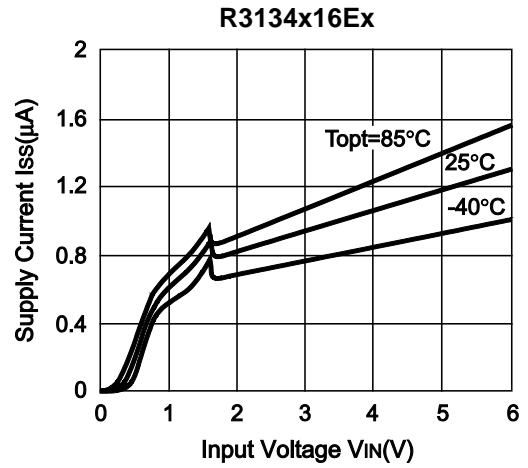
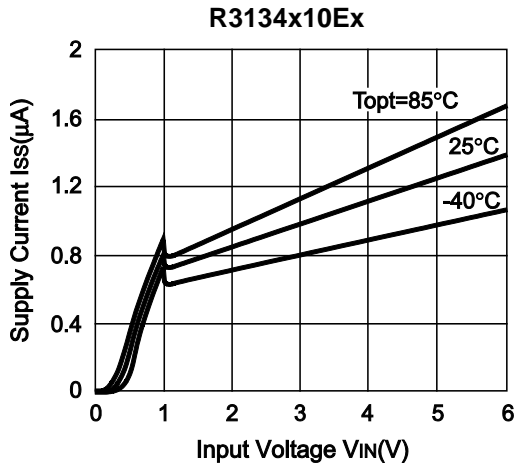

2) Detector Threshold vs. Temperature

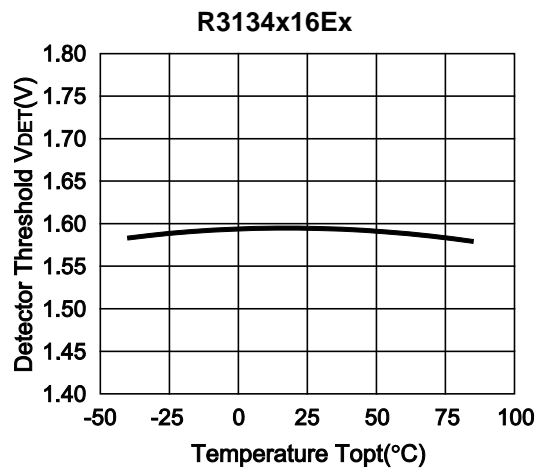
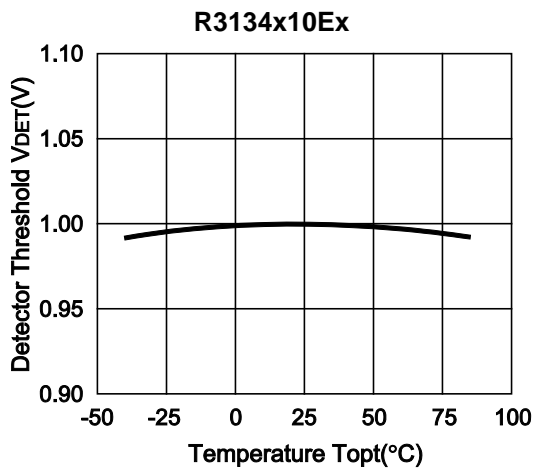

R3134x

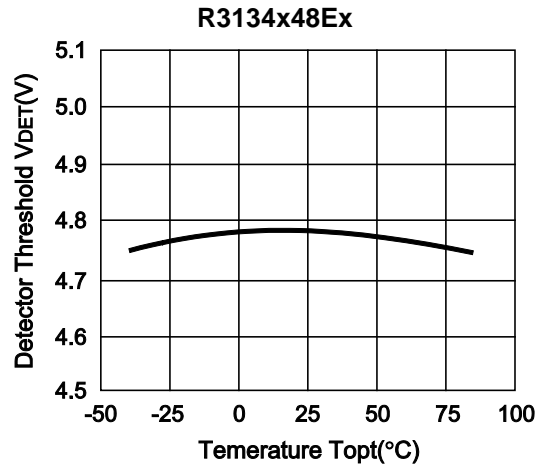
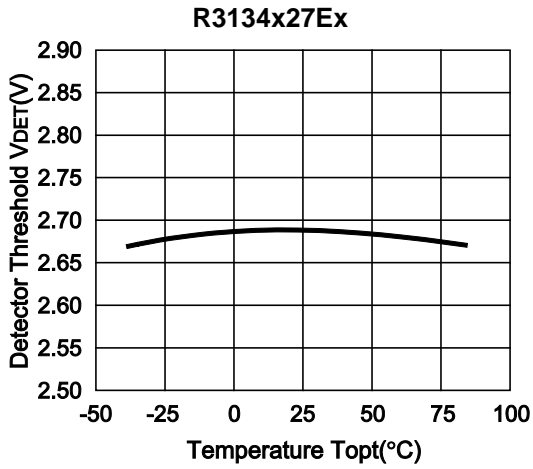

3) Nch Driver Output Current vs. V_{DS} (T_{opt}=25°C)

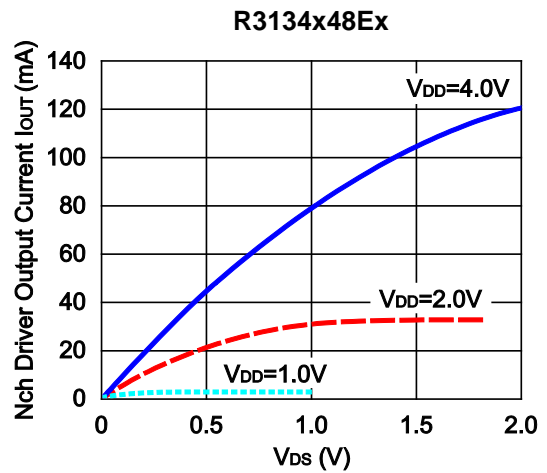
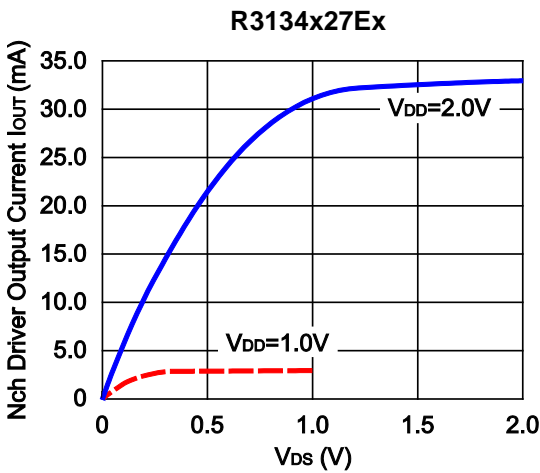
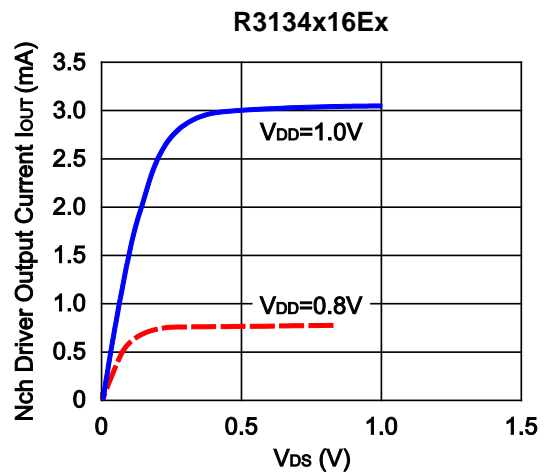
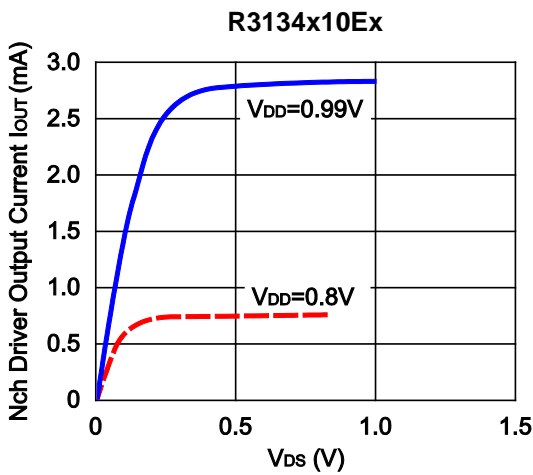

4) Nch Driver Output Current vs. Input Voltage

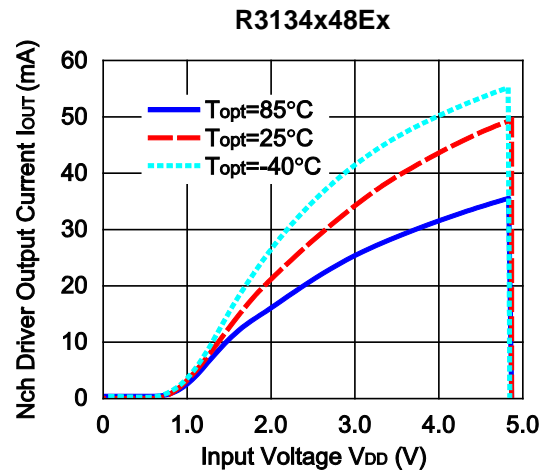
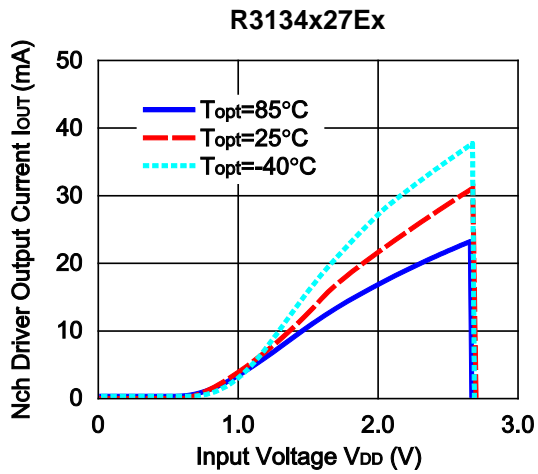
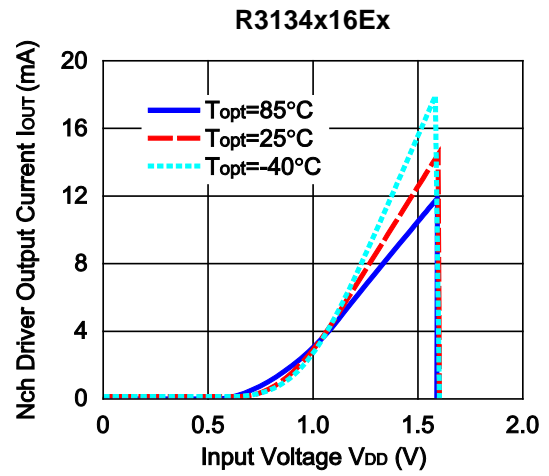
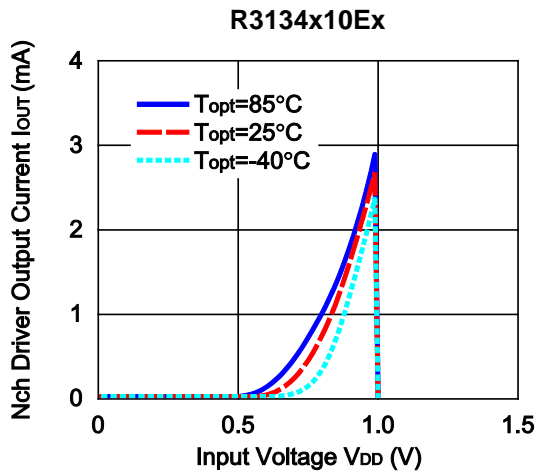

5) Pch Driver Output Current vs. V_{DS}

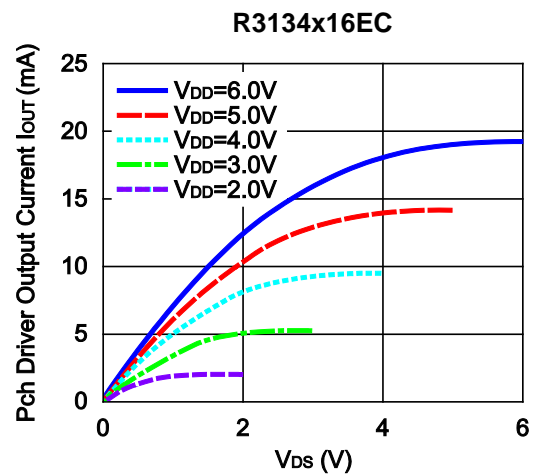
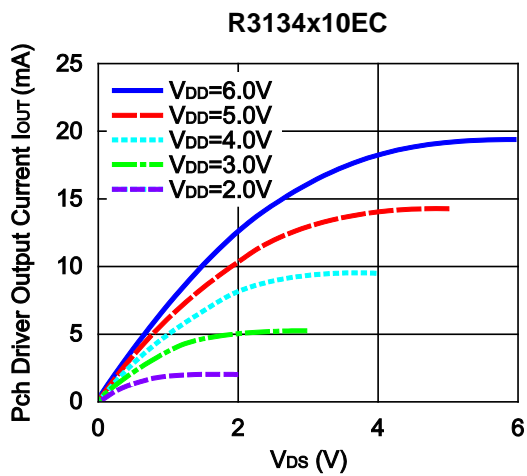

* R3134K (DFN(PLP)1212-6) and R3134Q (SC-88A) are the discontinued products as of March, 2016.

R3134x

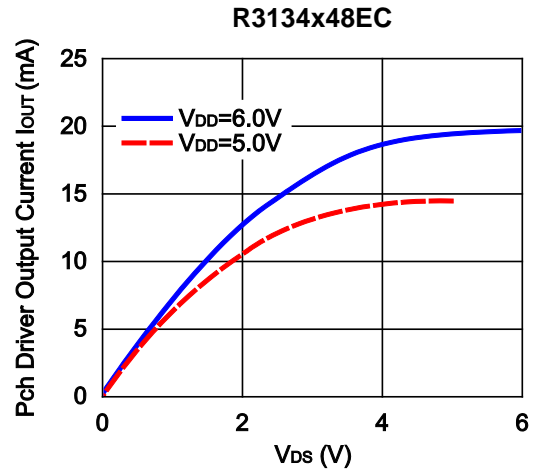
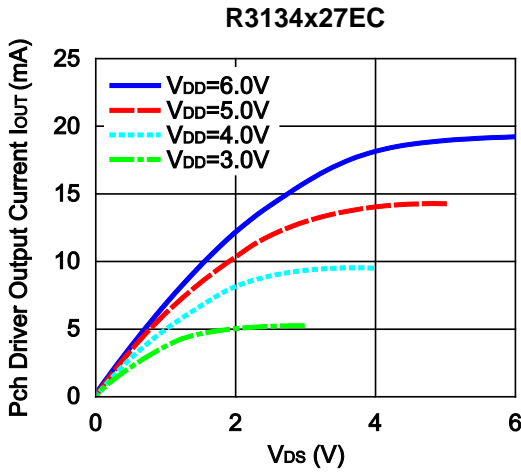

6) Pch Driver Output Current vs. Input Voltage

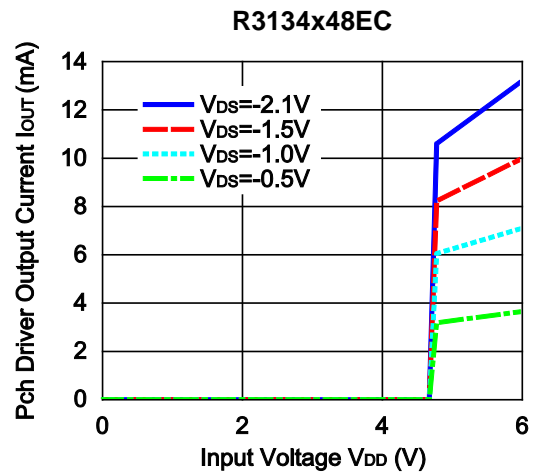
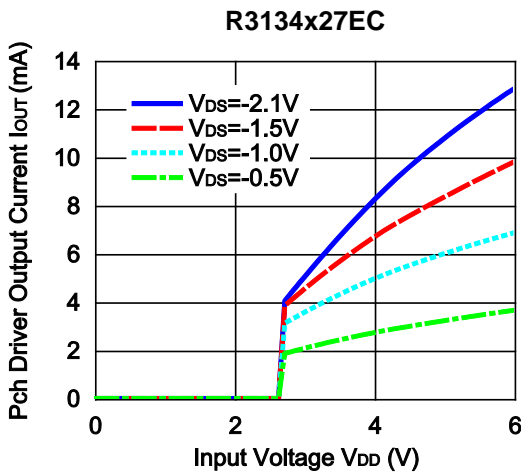
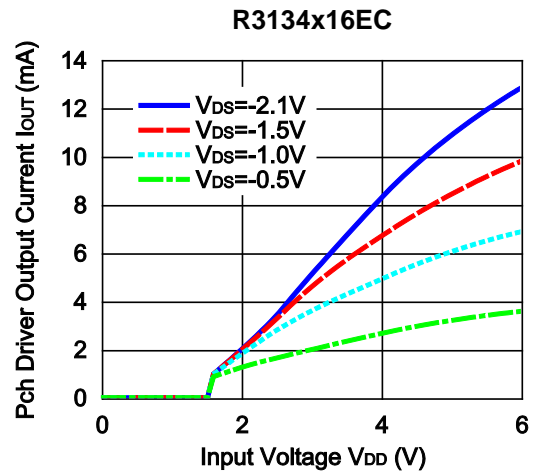
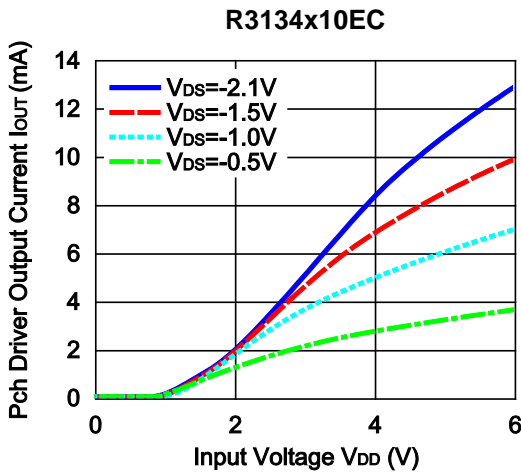

7) Output Delay Time at Detection Mode vs. Temperature

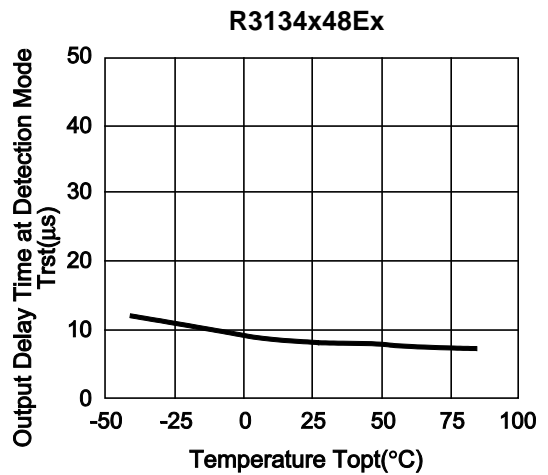
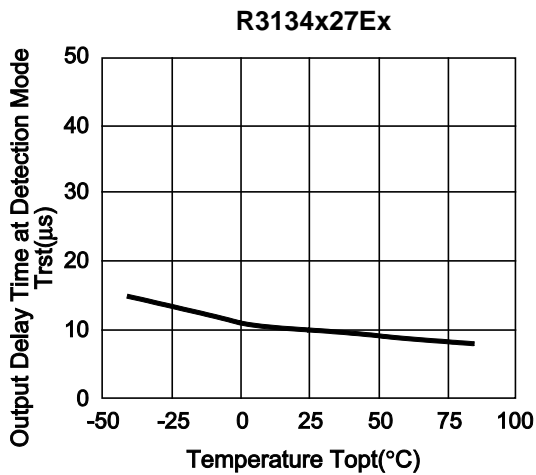
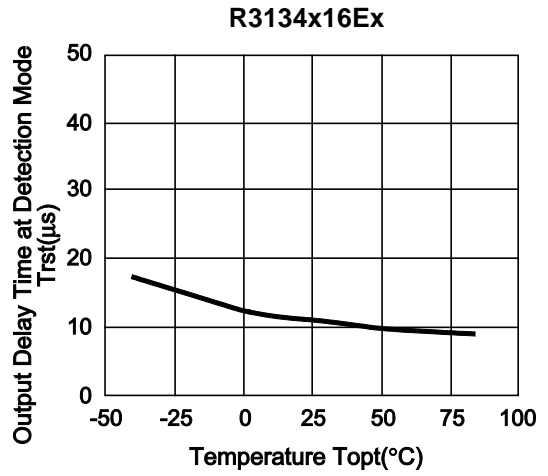
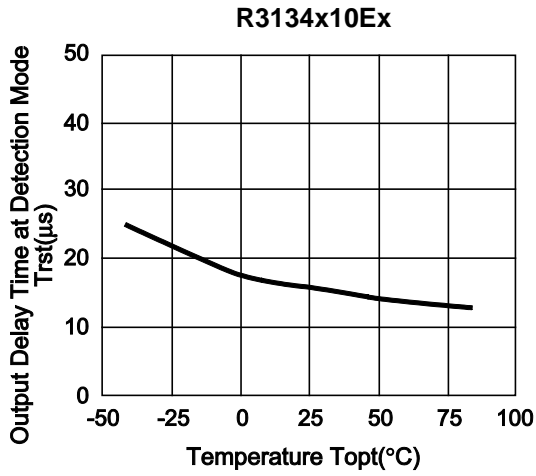

8) Power-on Reset Delay Time vs. Temperature

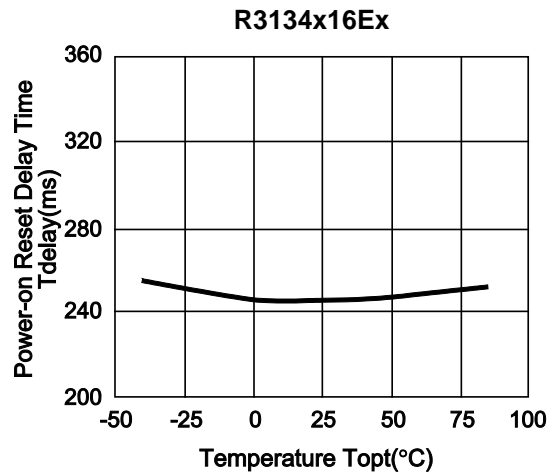
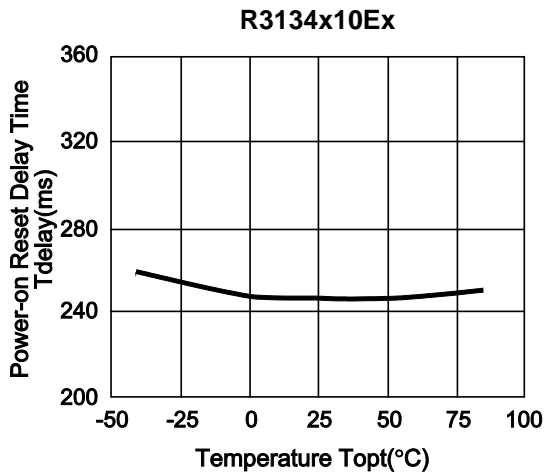

R3134x

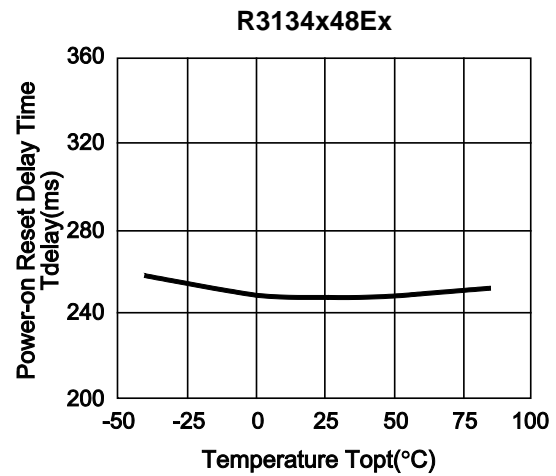
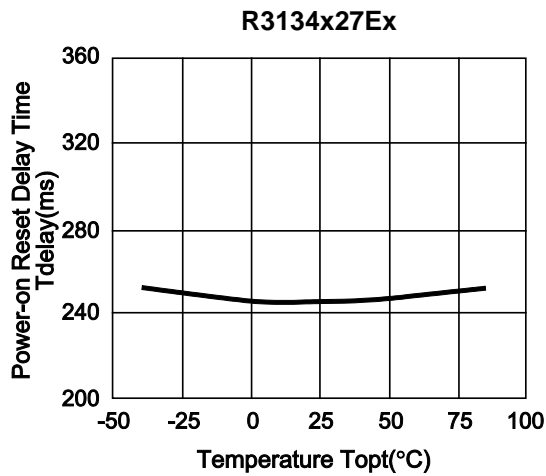

TECHNICAL NOTES

When connecting resistors to the device's input pin

When connecting a resistor (R1) to an input of this device, the input voltage decreases by [Device's Consumption Current] x [Resistance Value] only. And, the cross conduction current*1, which occurs when changing from the detecting state to the release state, is decreased the input voltage by [Cross Conduction Current] x [Resistance Value] only. And then, this device will enter the re-detecting state if the input voltage reduction is larger than the difference between the detector voltage and the released voltage.

When the input resistance value is large and the VDD is gone up at mildly in the vicinity of the released voltage, repeating the above operation may result in the occurrence of output.

As shown in Figure A/B, set R1 to become 100 kΩ or less as a guide, and connect C_{IN} of 0.1 μF and more to between the input pin and GND. Besides, make evaluations including temperature properties under the actual usage condition, with using the evaluation board like this way. As a result, make sure that the cross conduction current has no problem.

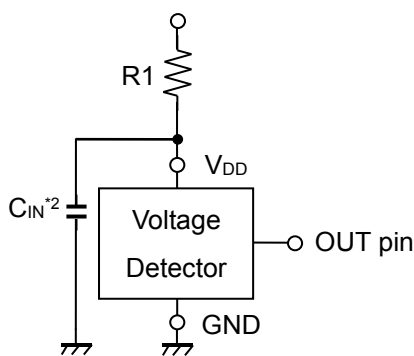

Figure A

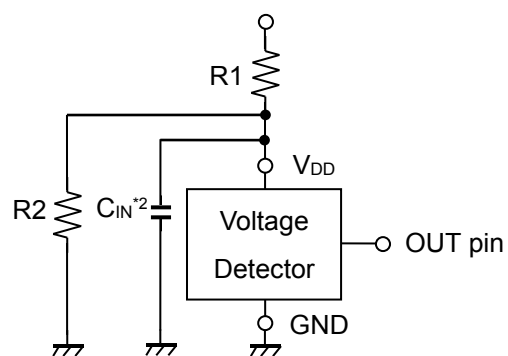

Figure B

*1 In the CMOS output type, a charging current for OUT pin is included.

*2 Note the bias dependence of capacitors.



1. The products and the product specifications described in this document are subject to change or discontinuation of production without notice for reasons such as improvement. Therefore, before deciding to use the products, please refer to Ricoh sales representatives for the latest information thereon.
2. The materials in this document may not be copied or otherwise reproduced in whole or in part without prior written consent of Ricoh.
3. Please be sure to take any necessary formalities under relevant laws or regulations before exporting or otherwise taking out of your country the products or the technical information described herein.
4. The technical information described in this document shows typical characteristics of and example application circuits for the products. The release of such information is not to be construed as a warranty of or a grant of license under Ricoh's or any third party's intellectual property rights or any other rights.
5. The products listed in this document are intended and designed for use as general electronic components in standard applications (office equipment, telecommunication equipment, measuring instruments, consumer electronic products, amusement equipment etc.). Those customers intending to use a product in an application requiring extreme quality and reliability, for example, in a highly specific application where the failure or misoperation of the product could result in human injury or death (aircraft, spacevehicle, nuclear reactor control system, traffic control system, automotive and transportation equipment, combustion equipment, safety devices, life support system etc.) should first contact us.
6. We are making our continuous effort to improve the quality and reliability of our products, but semiconductor products are likely to fail with certain probability. In order to prevent any injury to persons or damages to property resulting from such failure, customers should be careful enough to incorporate safety measures in their design, such as redundancy feature, fire containment feature and fail-safe feature. We do not assume any liability or responsibility for any loss or damage arising from misuse or inappropriate use of the products.
7. Anti-radiation design is not implemented in the products described in this document.
8. The X-ray exposure can influence functions and characteristics of the products. Confirm the product functions and characteristics in the evaluation stage.
9. WLCSP products should be used in light shielded environments. The light exposure can influence functions and characteristics of the products under operation or storage.
10. There can be variation in the marking when different AOI (Automated Optical Inspection) equipment is used. In the case of recognizing the marking characteristic with AOI, please contact Ricoh sales or our distributor before attempting to use AOI.
11. Please contact Ricoh sales representatives should you have any questions or comments concerning the products or the technical information.



Ricoh is committed to reducing the environmental loading materials in electrical devices with a view to contributing to the protection of human health and the environment.

Ricoh has been providing RoHS compliant products since April 1, 2006 and Halogen-free products since April 1, 2012.

RICOH RICOH ELECTRONIC DEVICES CO., LTD.

<https://www.e-devices.ricoh.co.jp/en/>

Sales & Support Offices

Ricoh Electronic Devices Co., Ltd.

Shin-Yokohama Office (International Sales)

2-3, Shin-Yokohama 3-chome, Kohoku-ku, Yokohama-shi, Kanagawa, 222-8530, Japan
Phone: +81-50-3814-7687 Fax: +81-45-474-0074

Ricoh Americas Holdings, Inc.

675 Campbell Technology Parkway, Suite 200 Campbell, CA 95008, U.S.A.
Phone: +1-408-610-3105

Ricoh Europe (Netherlands) B.V.

Semiconductor Support Centre

Prof. W.H. Keesomlaan 1, 1183 DJ Amstelveen, The Netherlands
Phone: +31-20-5474-309

Ricoh International B.V. - German Branch

Semiconductor Sales and Support Centre

Oberrather Strasse 6, 40472 Düsseldorf, Germany
Phone: +49-211-6546-0

Ricoh Electronic Devices Korea Co., Ltd.

3F, Haesung Bldg, 504, Teheran-ro, Gangnam-gu, Seoul, 135-725, Korea
Phone: +82-2-2135-5700 Fax: +82-2-2051-5713

Ricoh Electronic Devices Shanghai Co., Ltd.

Room 403, No.2 Building, No.690 Bibo Road, Pu Dong New District, Shanghai 201203,
People's Republic of China
Phone: +86-21-5027-3200 Fax: +86-21-5027-3299

Ricoh Electronic Devices Shanghai Co., Ltd.

Shenzhen Branch

1205, Block D (Jinlong Building), Kingkey 100, Hongbao Road, Luohu District,
Shenzhen, China
Phone: +86-755-8348-7600 Ext 225

Ricoh Electronic Devices Co., Ltd.

Taipei office

Room 109, 10F-1, No.51, Hengyang Rd., Taipei City, Taiwan (R.O.C.)
Phone: +886-2-2313-1621/1622 Fax: +886-2-2313-1623