



Alloy Film Low Resistance Chip Resistors (RBL Series)

Document No	TRBL-XX0S001L
Issued date	2019/05/29
Page	1/9

1. Scope :

The specification applies for the RBL Series (0603 ~ 2512) of alloy film low resistance chip resistors made by TA-I and the resistance range between 10mΩ and 91mΩ.

2. Features:

- ◆ Low Resistance and High Accuracy Resistor for Current Detection
- ◆ Large Electrode (All series)
- ◆ Good Performance for Heat Dissipation
- ◆ High Purity Alumina Substrate for High Power Dissipation
- ◆ Pb-free to Meet RoHS Requirements

3. Applications:

- ◆ Power Management Applications
- ◆ Switching Power Supply
- ◆ DC-DC Converter, Battery Pack, Charger, Adaptor
- ◆ Portable Instruments (PDA and Cell Phone)
- ◆ Voltage Regulation Module (VRM)
- ◆ Computer

4. Type Designation:

RBL	10	F	T	R030
Low Ohm Chip Resistors	Size/Power Rating	Tolerance Of Resistance at 25°C	Packaging	Nominal Resistance
	06:0603:0.25W 10:0805:0.5W 12:1206:0.5W 20:2010:0.75W 25:2512:1W	F:±1.0% G:±2.0% J:±5.0%	T: Paper E: Embossed	R030 : 30mΩ



Alloy Film Low Resistance Chip Resistors (RBL Series)

Document No	TRBL-XX0S001L
Issued date	2019/05/29
Page	2/9

5. Dimensions:

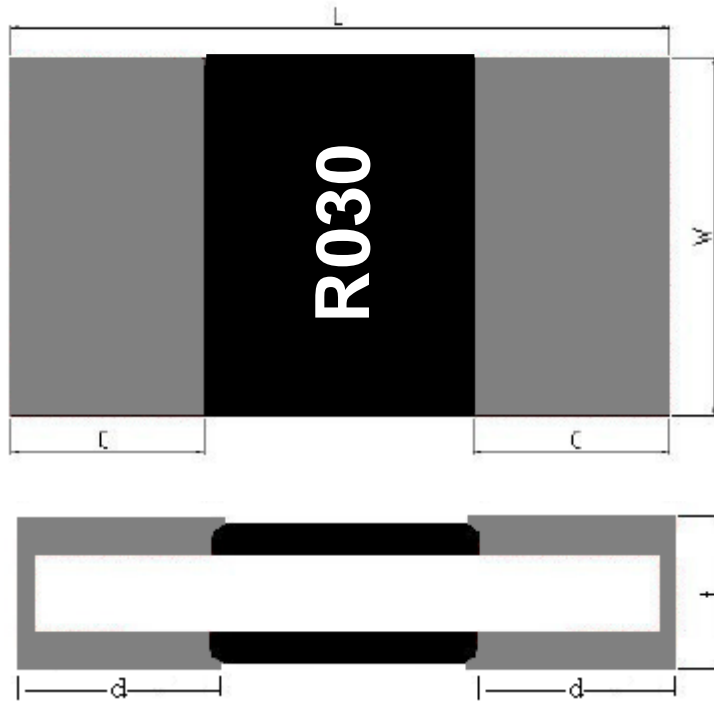

Unit: mm

Item	L	w	c	d	t
RBL06	1.60±0.1	0.90±0.1	0.47±0.1	0.47±0.1	0.50±0.1
RBL10	2.00±0.1	1.30±0.1	0.55±0.1	0.55±0.1	0.62±0.1
RBL12	3.10±0.1	1.60±0.1	1.10±0.2	1.10±0.2	0.62±0.2
RBL20	5.00±0.2	2.60±0.2	1.80±0.2	1.80±0.2	0.62±0.2
RBL25	6.30±0.2	3.20±0.2	2.0±0.3	2.0±0.3	0.65±0.2



Alloy Film Low Resistance Chip Resistors (RBL Series)

Document No	TRBL-XX0S001L
Issued date	2019/05/29
Page	3/9

6. Electrical Characteristics

Chip Size	Power Rating	TCR (ppm/°C)	Resistance Range (mΩ)			Operating Temp. Range
			F : ±1%	G : ±2%	J : ±5%	
0603	0.25W	± 200	10~20			-55°C~ +155°C
		± 100	21~91			
0805	0.5W	± 200	10~20			
		± 100	21~91			
1206	0.5W	± 200	10~20			
		± 100	21~91			
2010	0.75W	± 200	10~20			
		± 100	21~91			
2512	1W	± 200	10~20			
		± 100	21~91			

7. Derating Curve

For resistors operated at ambient temperature over 70°C, power rating shall be derated in accordance with figure 1.

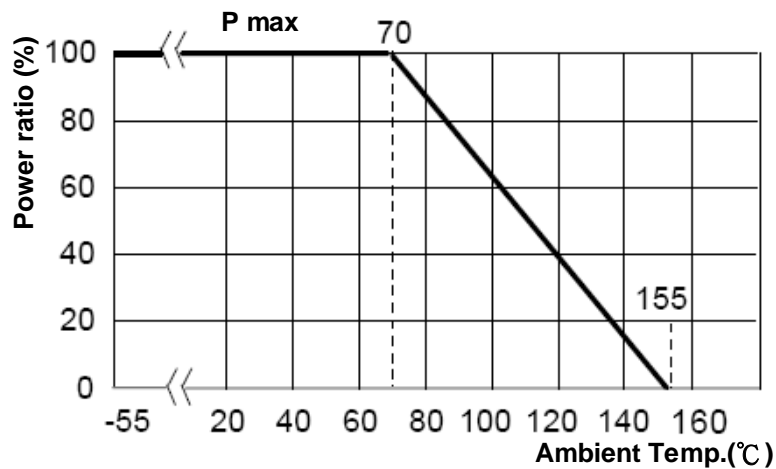

Figure 1



Alloy Film Low Resistance Chip Resistors (RBL Series)

Document No	TRBL-XX0S001L
Issued date	2019/05/29
Page	4/9

8. Reliability Tests:

Test Item	Reference standard	Condition of Test	Test Limits
Temperature Coefficient of Resistance	IEC60115-1-4.8 JIS-C5201-1-4.8	-55 ~ +125°C	Refer to paragraph 6
Short Time Overload	IEC60115-1-4.13 JIS-C5201-1-4.13	2.5 X rated voltage, 5s	± (1%+0.001 Ω)
Load Life	IEC60115-1-4.25.1 JIS-C5201-1-4.25.1	1000 hours at rated power , 70°C , 1.5hours "ON " , 0.5hour "OFF"	± (2%+0.001 Ω)
Load Life with Humidity	IEC60115-1-4.24 JIS-C5201-1-4.24	1000 hours at rated power , 40 ± 2°C , 90~95% RH 1.5hours "ON " , 0.5hour "OFF"	± (2%+0.001 Ω)
Rapid Change of Temperature	IEC60115-1-4.19 JIS-C5201-1-4.19	-55°C (30 min.) / +125 °C (30 min.) 5 cycles	± (1%+0.001 Ω)
Resistance to Soldering Heat	IEC60115-1-4.18 JIS-C5201-1-4.18	270 ± 5°C solder , 10 ± 1 sec dwell .	± (1%+0.001 Ω)
Solderability	IEC60115-1-4.17 JIS-C5201-1-4.17	245±5°C solder , 2±0.5 sec dwell. Solder : Sn96.5 / Ag3.0 / Cu0.5	At least 95% of surface area of electrode shall be covered with new solder.
Robustness of Termination (Bending Strength)	IEC60115-1-4.33 JIS-C5201-1-4.33	RBL06 、 10 、 12 : 3mm deflection RBL20 、 25 : 2mm deflection	± (1%+0.001Ω)
Resistance to Dry Heat	IEC60115-1-4.23.2 JIS-C5201-1-4.23.2	125 ± 5°C for 96 ± 4hrs	± (1%+0.001 Ω)

9. Marking:

From 0805 to 2512:

Resistance value is expressed by 4 digits, the first "R" means decimal point and the other digits represent for the normal resistance in Ω.

eg., 15mΩ= R015

For 0603: No Marking.



Alloy Film Low Resistance Chip Resistors (RBL Series)

Document No	TRBL-XX0S001L
Issued date	2019/05/29
Page	5/9

10. Taping & Reel

10.1 Taping Dimensions

10.1.1 4 mm pitch paper

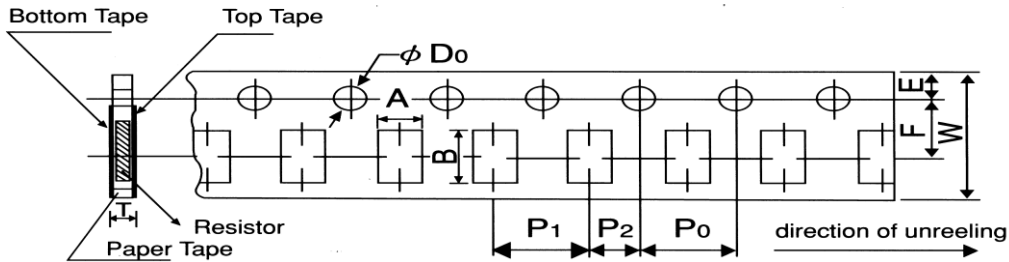

Packing	Type	A	B	W	F	E	P ₁	P ₂	P ₀	D ₀	T
Paper Tape	RBL06	1.1±0.1	1.9±0.1	8.0±0.2	3.5±0.05	1.75±0.1	4.0±0.1	2.0±0.1	4.0±0.1	Φ1.5 +0.1 -0.1	0.64±0.1
	RBL10	1.6±0.15	2.4±0.2								0.84±0.1
	RBL12	2.0±0.15	3.6±0.2								0.84±0.1

UNIT: mm

10.1.2 4 mm pitch Emboss

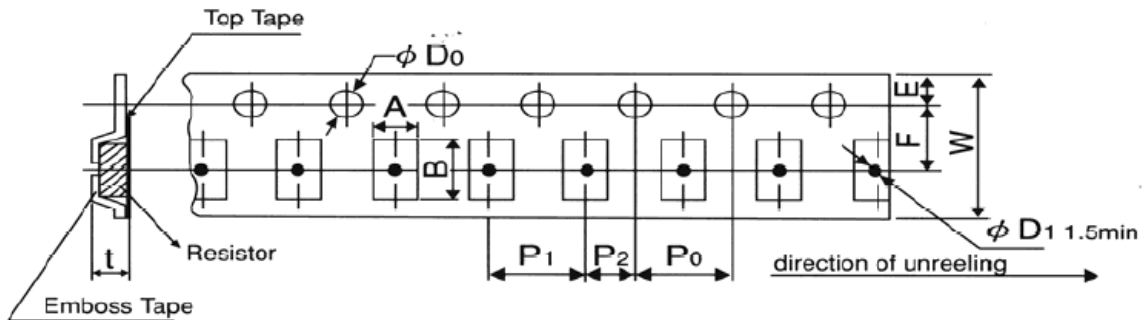

Packing	Type	A	B	W	F	E	P ₁	P ₂	P ₀	D ₀	T
Emboss	RBL20	2.8±0.2	5.3±0.2	12.0±0.2	5.5±0.05	1.75±0.1	4.0±0.1	2.0±0.05	4.0±0.05	Φ1.5 +0.1 -0.1	0.85±0.15
	RBL25	3.6±0.2	6.9±0.2								

UNIT: mm



Alloy Film Low Resistance Chip Resistors (RBL Series)

Document No	TRBL-XX0S001L
Issued date	2019/05/29
Page	6/9

10.2 Reel Specifications

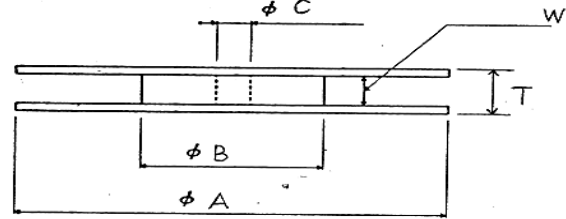
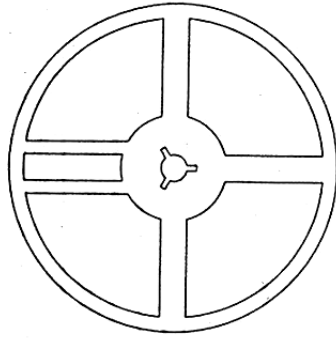

UNIT: mm

Type	ΦA	ΦB	ΦC	W	T
RBL06 RBL10 / 12	178.0 ±2.0	60.0 ±1.0	13.0 ±1.0	9.0 ±1.0	11.4 ±1.0
RBL20 / 25				13.0 ±1.0	15.5 ±1.0

10.3 Peel – off force :

Peel – off force of paper and blister tape is in accordance with “JIS ”
that is , 0.1 to 0.7 N at a peel-off speed of 300 mm / minute.

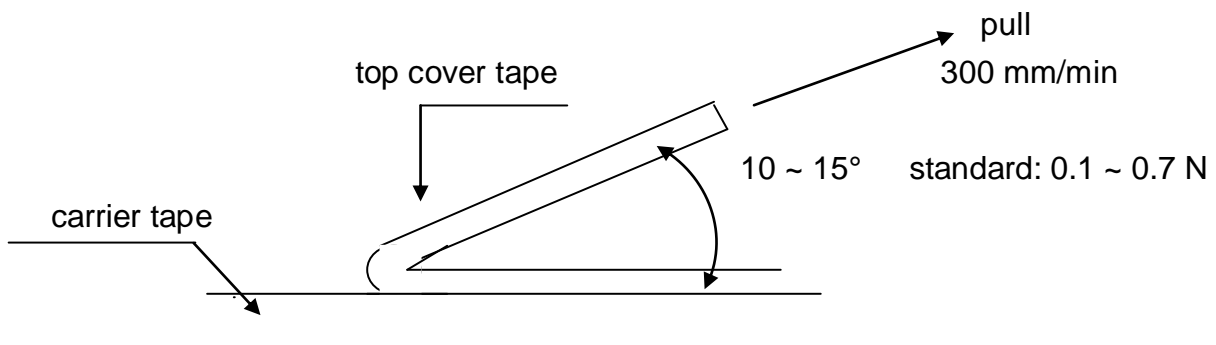

UNIT: mm



Alloy Film Low Resistance Chip Resistors (RBL Series)

Document No	TRBL-XX0S001L
Issued date	2019/05/29
Page	7/9

11. Label

11.1 Normal Products :

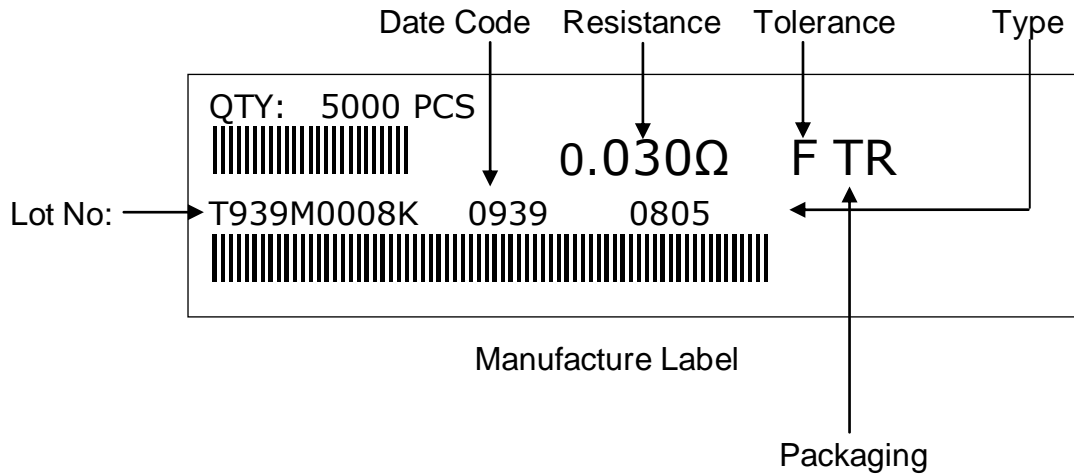

12. Recommended land patterns

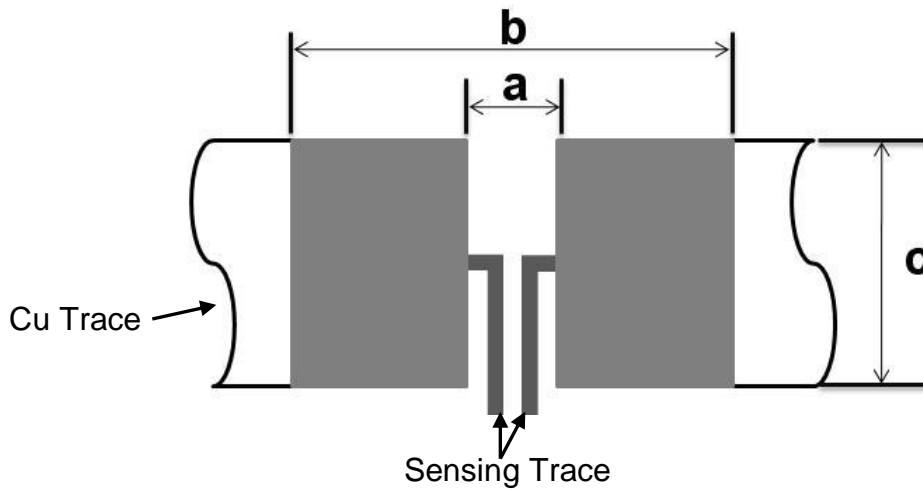

Land pattern		Dimension (mm)		
Type	Size	a	b	c
RBL	06 (0603)	0.7±0.10	3.3±0.10	1.4±0.10
RBL	10 (0805)	0.7±0.20	3.3±0.20	1.7±0.20
RBL	12 (1206)	0.7±0.20	5.1±0.20	2.5±0.20
RBL	20 (2010)	1.0±0.20	6.1±0.20	3.5±0.20
RBL	25 (2512)	1.0±0.20	7.5±0.20	4.2±0.20

13. ECN

Engineering Change Notice: The customer will be informed with ECN if there is significant modification on the characteristics and materials described in Approval Sheet.



Alloy Film Low Resistance Chip Resistors (RBL Series)

Document No	TRBL-XX0S001L
Issued date	2019/05/29
Page	8/9

14. Storage Conditions:

Temperature: 5°C ~35°C, Humidity: 40%~75%

15. Shelf Life:

2 years from manufacturing date.

16. Recommend IR – Reflow profile : (solder : Sn96.5 / Ag3 / Cu0.5)

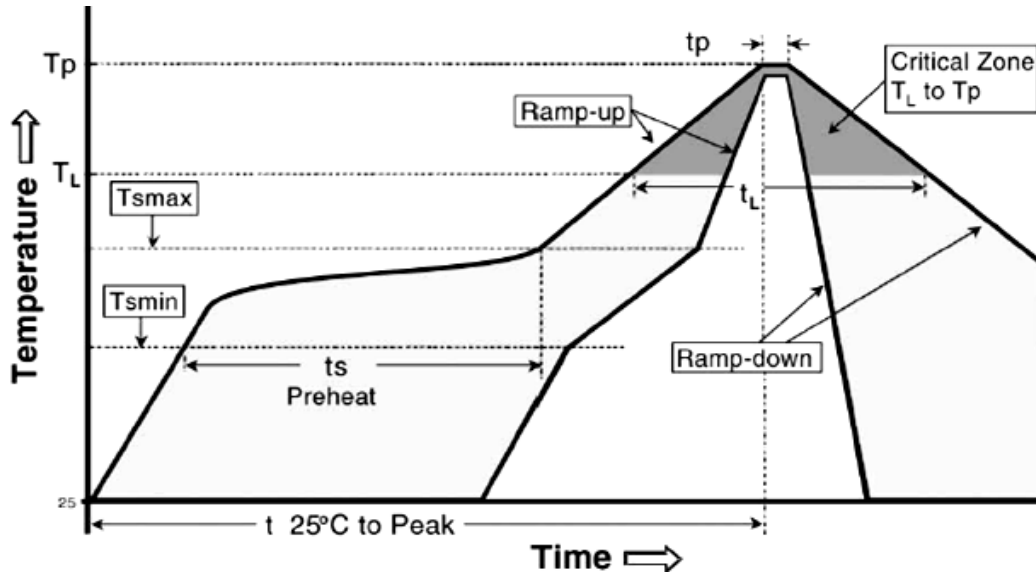

Profile Feature	Lead (Pb)-Free Assembly
Average ramp-up rate (T _{smax} to T _p)	3°C / second max.
Preheat - Temperature Min (T _{smin}) - Temperature Max (T _{smax}) - Time (T _{smin} to T _{smax}) (ts)	150°C 200°C 60 -150 seconds
Time maintained above : - Temperature (T _L) - Time (T _L)	217°C 60-120 seconds
Peak Temperature (T _p)	260°C
Time within $\begin{matrix} +0 \\ -5 \end{matrix}$ °C of actual Peak Temperature (tp) ²	10 seconds
Ramp-down Rate	6°C/second max.
Time 25°C to Peak Temperature	8minutes max.

Alloyed Re-flow times : 3 times

Remark : To avoid discoloration phenomena of chip on terminal electrodes,
please use N2 Re-flow furnace



**Alloy Film
Low Resistance Chip Resistors
(RBL Series)**

Document No	TRBL-XX0S001L
Issued date	2019/05/29
Page	9/9

17. Manufacturing Country & City :

TA-I TECHNOLOGY CO., LTD. (Taiwan– Tao Yuan)

Tel: (+886) 3-3246169 Fax : (+886) 3-3246167

Associated companies :

(1)TA-I TECHNOLOGY (SU ZHOU) CO., LTD. (China – Su Zhou)

Tel :(+86) 512-63457879 Fax : (+86) 512-63457869

(2) TA-I TECHNOLOGY ELECTRONIC (DONGGUAN) CO., LTD. (China –Dongguan)

Tel : (+86) 769-8339-4790~3 Fax : (+86) 769-8339-4794

(3) FORTUNE TASK RESISTOR FACTORY (China – Dongguan)

Tel : (+86) 769-8339-4790~3 Fax : (+86) 769-8339-4794

(4) TAI OHM ELECTRONICS (M) SDN. BHD. (Malaysia – Penang)

Tel :(+60) 4- 3900480 Fax : (+60) 4-3901481

(5) TAI ELECTRONICS Indonesia (Indonesia – Jakarta)

Tel :62-21-89830123 Fax : 62-21-89830703



Alloy Film Low Resistance Chip Resistors (RBL Series)

Document No TRBL-XX0S001L

Issued date 2019/05/29

Page 10/9

18. Revise record :

Date	Content	Owner
2011.06.23	Update paragraph 6. The resistance range from 20~91Ω to 10~91mΩ	Ian
2011.06.30	Chip size 0603&0805 has two type of power rating. Define for one power rating.	Ian
2011.07.08	Update Derating curve & paragraph 6.	Ian
2011.12.30	Remove RBL13 in 12. Recommended land patterns.	Ian
2012.02.01	Update paragraph 6. Add the resistance rang 10~20mΩ in chip size 0603 tolerance F&G.	Lung
2012.03.01	Update paragraph 9. For 0603. No marking	Lung
2012.04.18	Remove RBL04 in RBL series.	Ian
2012.07.23	Adding "alloy film" in paragraph 1.	Ian
2012.09.21	Update operating temp. range from -55~125°C to -55~155°C in paragraph 6.	Ian
2012.10.18	Update paragraph 7. Derating Curve, exchange a new figure. Reliability test : Reference standard from JIS-5202 change to IEC60115 & JIS-C5201-1 Update paragraph 11. Recommended land patterns added current trace & sensing trace. Update paragraph 16. Recommend IR – Reflow profile Exchange a new figure.	Ian
2013.10.15	Update paragraph 5 Dimensions, define the L size for RBL12. And the t size for RBL10.	Ian



Alloy Film Low Resistance Chip Resistors (RBL Series)

Document No	TRBL-XX0S001L
Issued date	2019/05/29
Page	11/9

Date	Content	Owner																																				
2014.06.12	<p>Update paragraph 5. For increasing power load design, the chip size was bigger than before. As showdown below.</p> <table border="1"><thead><tr><th>Item</th><th>L</th><th>w</th><th>c</th><th>d</th><th>t</th></tr></thead><tbody><tr><td>RBL06</td><td>1.60±0.1</td><td>0.90±0.1</td><td>0.47±0.1</td><td>0.47±0.1</td><td>0.50±0.1</td></tr><tr><td>RBL10</td><td>2.00±0.1</td><td>1.30±0.1</td><td>0.55±0.1</td><td>0.55±0.1</td><td>0.62±0.1</td></tr><tr><td>RBL12</td><td>3.10±0.1</td><td>1.60±0.1</td><td>1.10±0.2</td><td>1.10±0.2</td><td>0.62±0.2</td></tr><tr><td>RBL20</td><td>5.00±0.2</td><td>2.60±0.2</td><td>1.80±0.2</td><td>1.80±0.2</td><td>0.62±0.2</td></tr><tr><td>RBL25</td><td>6.30±0.2</td><td>3.20±0.2</td><td>2.0±0.3</td><td>2.0±0.3</td><td>0.65±0.2</td></tr></tbody></table>	Item	L	w	c	d	t	RBL06	1.60±0.1	0.90±0.1	0.47±0.1	0.47±0.1	0.50±0.1	RBL10	2.00±0.1	1.30±0.1	0.55±0.1	0.55±0.1	0.62±0.1	RBL12	3.10±0.1	1.60±0.1	1.10±0.2	1.10±0.2	0.62±0.2	RBL20	5.00±0.2	2.60±0.2	1.80±0.2	1.80±0.2	0.62±0.2	RBL25	6.30±0.2	3.20±0.2	2.0±0.3	2.0±0.3	0.65±0.2	Ian
Item	L	w	c	d	t																																	
RBL06	1.60±0.1	0.90±0.1	0.47±0.1	0.47±0.1	0.50±0.1																																	
RBL10	2.00±0.1	1.30±0.1	0.55±0.1	0.55±0.1	0.62±0.1																																	
RBL12	3.10±0.1	1.60±0.1	1.10±0.2	1.10±0.2	0.62±0.2																																	
RBL20	5.00±0.2	2.60±0.2	1.80±0.2	1.80±0.2	0.62±0.2																																	
RBL25	6.30±0.2	3.20±0.2	2.0±0.3	2.0±0.3	0.65±0.2																																	
2019/05/29	<p>Update paragraph 5 For picture, the electrode is higher than over coating.</p> 	Soul																																				