

MAPX	MODIFICATION	DATE
------	--------------	------

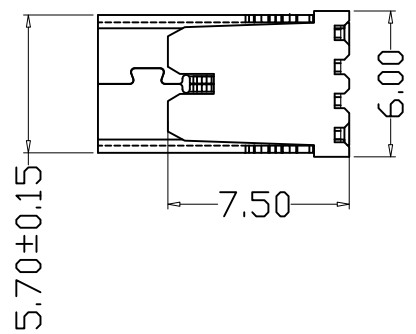

NOTE:
 1. Material:
 Housing: Thermoplastics
 Contact: Phosphor Bronze C5191-EH/C2680-EH, T=0.25mm
 Shell: COPPER ALLOY T=0.30mm
 2. FINISH:
 Contact: 15u" Gold Plated on Contact Area,
 80u" Min.Tin Plated on Solder Area
 50u" Min.Nickel Underplating Over All.
 Shell: 50u" Min.Nickel Underplating Over All.
 3. Specification:
 3.1: Rating:
 Rated voltage 500V AC/DC. Rated current: 2 A Max.
 3.2: Electrical:
 Insulation Resistance(EIA-364-21):
 1000MΩ Min. at 500V/DC for 1Minute.
 Contact Resistance(EIA-364-23):
 30 mΩ Max. at 20mV Max, 50mA
 Dielectric Withstanding Voltage(EIA-364-20):
 No discharge, flashover or breakdown at 500V/AC
 1Minute
 4. Plug extraction force shall be between 1.0kgf and 2.00kgf
 5. Contact finish:
 01: Selective Gold Flash
 02: Selective Gold 3U"
 03: Selective Gold 5U"
 04: Selective Gold 15U"
 05: Selective Gold 30U"

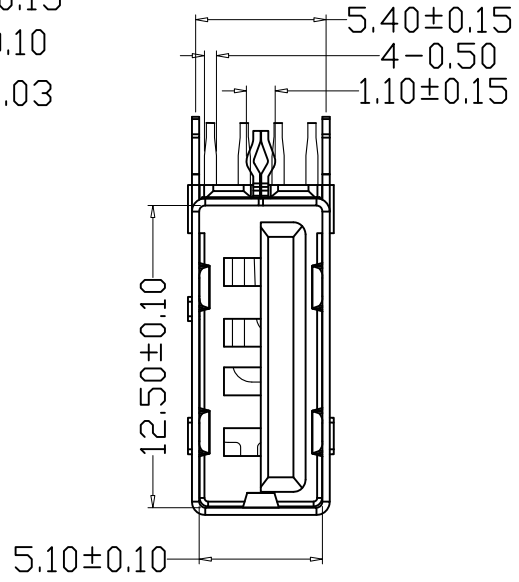
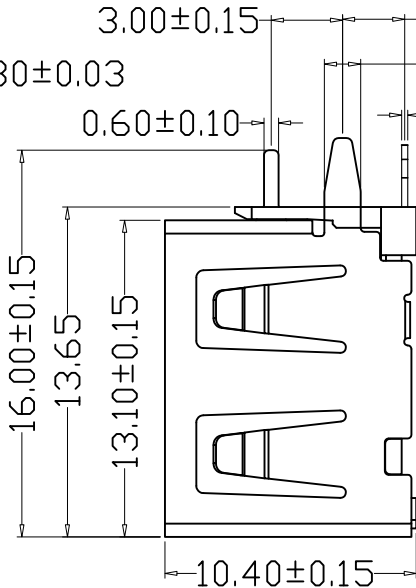
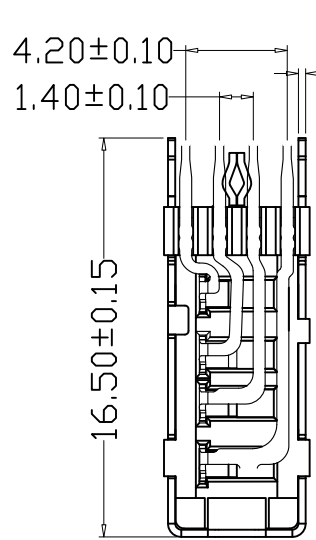
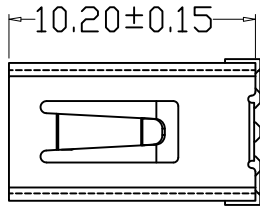
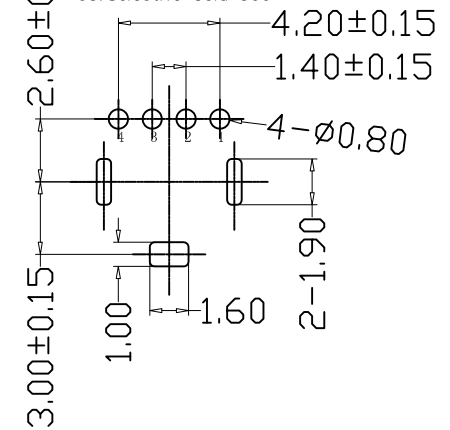

RECOMMENDED PCB LAYOUT
 GENERAL TOLERANCES: ±0.05

产品图 PRODUCT CHART DWG		深圳市精拓金电子有限公司							
公差一览表 TOLERANCE UNLESS OTHERWISE		单位 UNITS	MM	制图 DRAWING	Z-Y-B	制图料号 PRODUCT PART NO.	906-562A1014D10200		
X.	±0.25	X.	±5.°	比例 SCALE	1:1	审核 CHKD	产品名称 PRODUCT NO.	AF10.0侧插短体外直内O型脚无边铜壳PBT白胶	
.X	±0.20	.X	±2.°	日期 DATE	2014.02.20	核准 APPD	角法 VIEW	版本 VER	AO
.XX	±0.15	.XX	±1.°						
.XXX	±0.10	.XXX	±0.5°						