

D款, 正向10.6后两脚, DIP-*6.20

MAPX	MODIFICATION	DATE

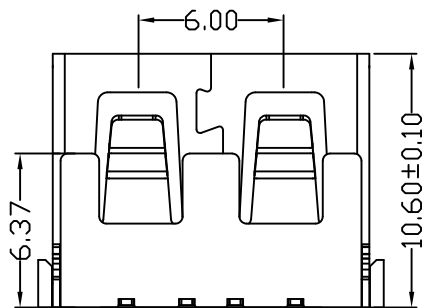
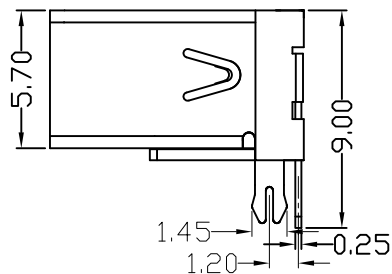
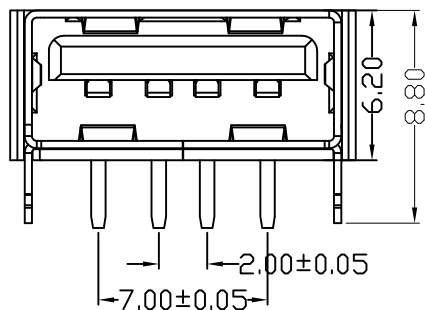
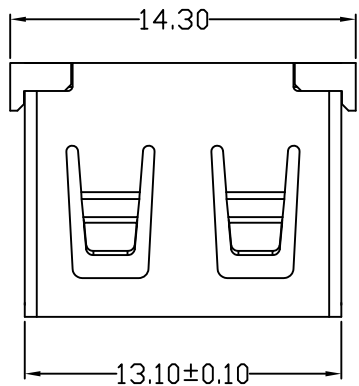

NOTES:

- 1.HOUSING: SEE NOTES, UL94V-0 .
- TERMINAL: SEE NOTES.
- SHELL: SEE NOTES.

SPECIFICATION:

- 1.ELECTRICAL CHARACTERISTIC:
 - CONTACT RESISTANCE: 30MΩ MAX
 - DIELECTRIC WITHSTANDING VOLTAGE: 500V AC FOR 1MIN
 - INSULATION RESISTANCE: 1000MΩ MIN
- 2.MECHANICAL CHARACTERISTIC:
 - INSERTION FORCE: 35N(3.57KGF) MAX
 - EXTRACTION FORCE: 10~35N(1.02~3.57KGF)MIN
 - DURABILITY: 1500 CYCLES EXTRACTION FORCE:10~35N
5000 CYCLES MIN
 - 5000 CYCLES EXTRACTION FORCE:3~35N

3.ENVIRONMENTAL:

OPERATING TEMPERATURE: -55°C+85°C

4.Contact finish:

- 01:Selective Gold Flash
- 02:Selective Gold 3U"
- 03:Selective Gold 5U"
- 04:Selective Gold 15U"
- 05:Selective Gold 30U"

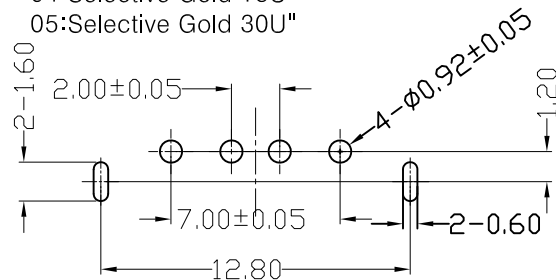

FRONT EDGE OF CONNECTOR
PCB LAYOUT (T=1.60mm)

产品图 PRODUCT CHART DWG				深圳市精拓金电子有限公司					
公差一览表 TOLERANCE UNLESS OTHERWISE				单位	MM	制图	Z-Y-B	制图料号	912-222A1011D10100
X.	±0.15	X.	±5.°	UNITS		DRAWING		产品名称	AF10.6D款后两脚无边方弹铜壳PBT白胶6.2DIP
.X	±0.10	.X	±2.°	SCALE	1:1	审核		PRODUCT NO.	
.XX	±0.05	.XX	±1.°	日期	2012.09.24	核准		角法	
.XXX	±0.03	.XXX	±0.5°	DATE		APPD		VIEW	
								版本	AD
								VER	