

零件承认书

SPECIFICATION FOR APPROVAL

客户名称: _____

客户料号: _____

增益料号: **GZ1608-102TF**

规格描述: **叠层磁珠**

日期: **2020/11/6**

版本: **A**

增益签核:

制订	审核	核准
张翔	刘业明	柯文学

客户签核:

工程	审核	核准



东莞市增益实业有限公司

地址: 东莞市塘厦镇林村塘厦大道北552号
 电话: 0769-87321000
 传真: 0769-87891229

物料类型:	叠层磁珠
日期:	2020/11/6
版本:	A

图面规格变更履历表

客户		0	料号		品名	
客户版本	增益版本	变更内容	日期	制定	审核	核准
	A	初版	2020/11/6	张翔	刘业明	柯文学
 <p> 东莞市增益实业有限公司 地址：东莞市塘厦镇林村塘厦大道北552号 电话：0769-87321000 传真：0769-87891229 </p>				物料类型：	叠层磁珠	
				日期：	2020/11/6	
				版本：	A	

SPECIFICATION

DIMENSION (Unit:mm) & SCHEMATIC

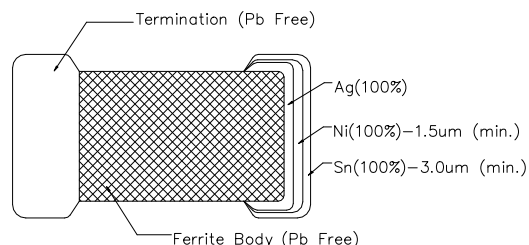
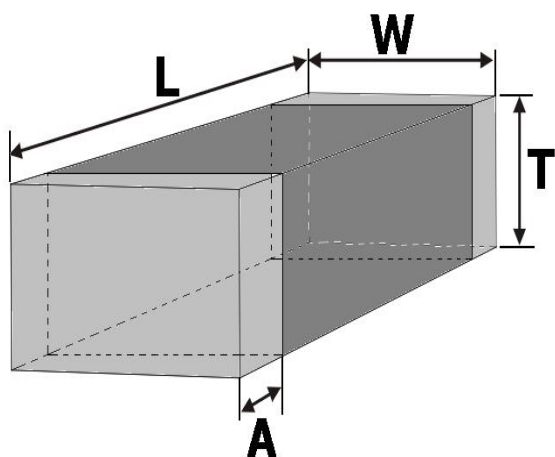

DIM	L	W	T	A				
MM	1.6	0.8	0.8	0.3				
SPEC	±0.15	±0.15	±0.15	±0.2				

ELECTRICAL CHARACTERISTIC: TEMPERATURE AT 25°C

ITEM	Z (Ω)	DCR (Ω)	I _{rms} (mA)
SPEC	1000±25%	0.6MAX	200MAX
	HP4286A	502BC	VR116
100 MHz			



东莞市增益实业有限公司
 地址: 东莞市塘厦镇林村塘厦大道北552号
 电话: 0769-87321000
 传真: 0769-87891229

物料类型:

叠层磁珠

日期:

2020/11/6

版本:

A

制订

张翔

审核

刘业明

核准

柯文学

样品检测成绩表

客户名称:	0										
规格描述:	GZ1608-102TF										
交货数量	抽样数	抽样基准 MIL-STD-105E ■ 正常 检验标准 <input type="checkbox"/> 加严 <input type="checkbox"/> 减严	判定标准		测试环境		分项检查判定				
			主要	次要	温度	湿度	尺寸	外观	特性		
5PCS	5PCS		0.1	0.4	25°C	75%		OK		OK	OK
绝缘电阻DC	COIL TO CORE	V	COIL TO CORE	V	测试仪器 <input type="checkbox"/> CH-9053 ■ HK-502BC						
		MΩ		MΩ	■ HP-4285 <input type="checkbox"/> CH-100 ■ HY-7110						
耐电压AC		SEC		SEC	<input type="checkbox"/> HP-4284 <input type="checkbox"/> CH-1320 <input type="checkbox"/> HK-310						
		KV		KV	<input type="checkbox"/> TF-6815 <input type="checkbox"/> HK-1062 ■ 卡尺						
测试条件	100MHZ										
PIN	Z(S-F) 100MHZ (Ω)			DCR(S-F) AT 25°C (Ω)							
SPEC	1000±25%			0.6MAX							
1	1051.00			0.520							
2	985.00			0.530							
3	1062.00			0.510							
4	1103.00			0.520							
5	962.00			0.530							
6											
7											
8											
9											
10											
X											
R											
备注: TEPM: 20°C (REF)					RH: 60% (REF)						
	东莞市增益实业有限公司				物料类型:		叠层磁珠				
	地址: 东莞市塘厦镇林村塘厦大道北552号				日期:		2020/11/6				
	电话: 0769-87321000				版本:		A				
传真: 0769-87891229											
制订	张翔	审核	刘业明	核准	柯文学						

Reflow soldering conditions

- Pre - heating should be in such a way that the temperature difference between solder and ferrite surface is limited to 150°C max. Also cooling into solvent after soldering should be in such a way that the temperature difference is limited to 100°C max.

Unenough pre - heating may cause cracks on the ferrite, resulting in the deterioration of product quality.

- Products should be soldered within the following allowable range indicated by the slanted line. The excessive soldering conditions may cause the corrosion of the electrode, When soldering is repeated, allowable time is the accumulated time.

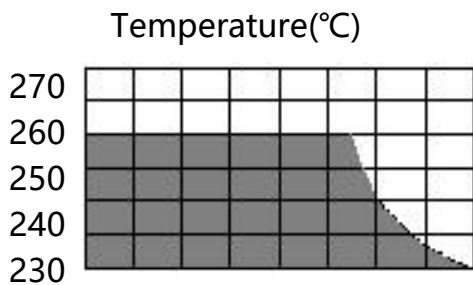

Temperature Profile

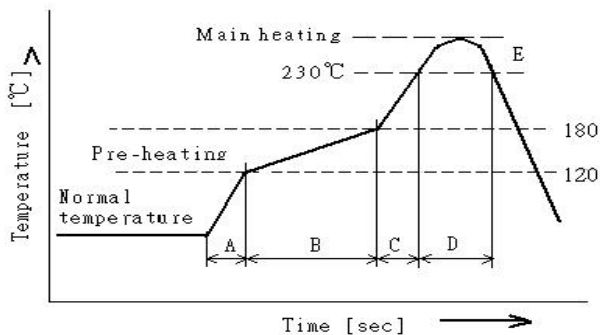

A	Slope of temp. rise	1 to 5	°C/sec
B	Heat time	50 to 150	sec
	Heat temperature	120 to 180	°C
C	Slope of temp. rise	1 to 5	°C/sec
D	Time over 230°C	90~120	sec
E	Peak temperature	255~260	°C
	Peak hold time	10 max.	sec
No. of mounting		3	times



东莞市增益实业有限公司
 地址：东莞市塘厦镇林村塘厦大道北552号
 电话：0769-87321000
 传真：0769-87891229

物料类型:

叠层磁珠

日期:

2019/5/10

版本:

A

制订

张翔

审核

刘业明

核准

柯文学

Reflow soldering conditions

Reworking with soldering iron

Preheating	150°C, 1 minute
Tip temperature	280°C max
Soldering time	3seconds max.
Soldering iron output	30w max.
End of soldering iron	φ3mm max.

Reworking should be limited to only one time.

Note: Do not directly touch the products with the tip of the soldering iron in order to prevent the crack on the ferrite material due to the thermal shock.

Solder Volume

Solder shall be used not to be exceed the upper limits as shown below.

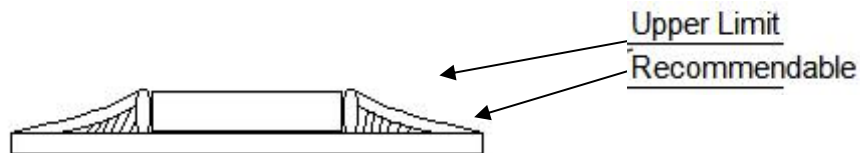

Accordingly increasing the solder volume, the mechanical stress to product is also increased. Exceeding solder volume may cause the failure of mechanical or electrical performance.



东莞市增益实业有限公司
地址：东莞市塘厦镇林村塘厦大道北552号
电话：0769-87321000
传真：0769-87891229

物料类型:

叠层磁珠

日期:

2020/11/6

版本:

A

制订

张翔

审核

刘业明

核准

柯文学

包装方式数量图示

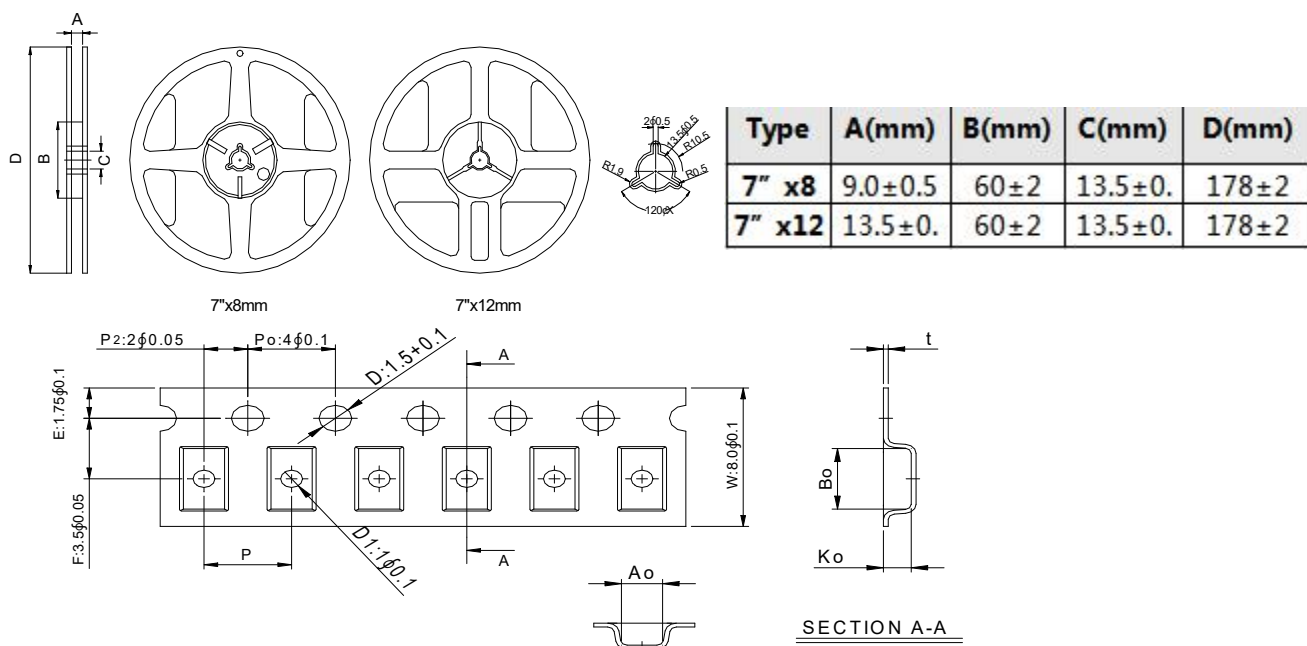

Series	Size	Bo(mm)	Ao(mm)	Ko(mm)	P(mm)	t(mm)	D1(mm)
FCB,FCM	100505	1.12±0.05	0.67±0.05	0.54±0.05	2.0±0.1	0.23±0.05	none
HCB,HPB	160808	1.80±0.10	1.01±0.10	1.02±0.10	4.0±0.1	0.22±0.05	none
HFB	201209	2.25±0.10	1.42±0.10	1.04±0.10	4.0±0.1	0.22±0.05	1.0±0.1
FCI	201212	2.35±0.10	1.50±0.10	1.45±0.10	4.0±0.1	0.22±0.05	1.0±0.1
FHI, FCH	321611	3.50±0.10	1.88±0.10	1.27±0.10	4.0±0.1	0.22±0.05	1.0±0.1
HCI	322513	3.42±0.10	2.77±0.10	1.55±0.10	4.0±0.1	0.22±0.05	1.0±0.1
FCA	321609	3.40±0.10	1.77±0.10	1.04±0.1	4.0±0.10	0.22±0.05	1.0±0.1



东莞市增益实业有限公司
 地址: 东莞市塘厦镇林村塘厦大道北552号
 电话: 0769-87321000
 传真: 0769-87891229

物料类型:

叠层磁珠

日期:

2020/11/6

版本:

A

制订

张翔

审核

刘业明

核准

柯文学

包装方式数量图示

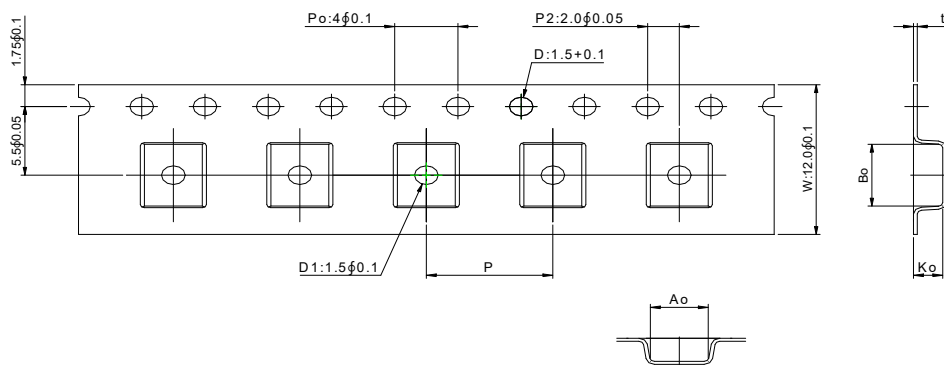

Series	Size	Bo(mm)	Ao(mm)	Ko(mm)	P(mm)	t(mm)	D1(mm)
FCB,	451616	4.95±0.1	1.93±0.1	1.93±0.1	4.0±0.1	0.24±0.05	1.5±0.1
HCB.FCM	453215	4.95±0.1	3.66±0.1	1.85±0.1	8.0±0.1	0.24±0.05	1.5±0.1
FCI	575018	6.10±0.1	5.40±0.1	2.00±0.1	8.0±0.1	0.30±0.05	1.5±0.1

Chip Size	575018	453215	451616	322513	321611	201212	201209	160808	100505
Chip / Reel	1000	1000	2000	2500	3000	2000	4000	4000	10000
Inner box	4000	4000	8000	12500	15000	10000	20000	20000	50000
Middle box	20000	20000	40000	62500	75000	50000	100000	100000	250000
Carton	40000	40000	80000	125000	150000	100000	200000	200000	500000
Bulk (Bags)	7000	12000	20000	30000	50000	100000	150000	200000	300000

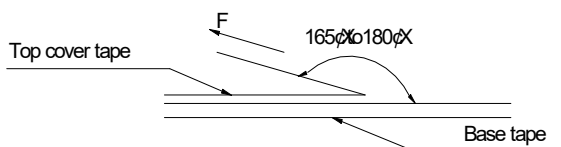

Room	Room	Room	Tearing
(°C)	(%)	(hPa)	mm/min
5~35	45~85	860~106	300

Application Notice

·Storage Conditions

To maintain the solderability of terminal electrodes:

1. Temperature and humidity conditions: -10~ 40°C and 30~70% RH.
2. Recommended products should be used within 6 months from the time of delivery.
3. The packaging material should be kept where no chlorine or sulfur exists in the air.

·Transportation

1. Products should be handled with care to avoid damage or contamination from perspiration and skin oils.
2. The use of tweezers or vacuum pick up is strongly recommended for individual components.
3. Bulk handling should ensure that abrasion and mechanical shock are minimized.



东莞市增益实业有限公司
地址：东莞市塘厦镇林村塘厦大道北552号
电话：0769-87321000
传真：0769-87891229

物料类型:

叠层磁珠

日期:

2020/11/6

版本:

A

制订

张翔

审核

刘业明

核准

柯文学

RELIABILITY AND TEST CONDITIONS

RELIABILITY AND TEST CONDITIONS

1 HIGH TEMPERATURE RESISTANCE

a. Performance specification

- 1.Appearance: no mechanical damage
- 2.Impedance shall be with $\pm 30\%$ of the initial value
3. DC resistance shall be satisfied

b.Test condition

- 1.Temperature $125^{\circ}\text{C} \pm 2^{\circ}\text{C}$
- 2.Applied current: Rated current(maximum value)
- 3.Testing time: 1008 ± 12 hrs
- 4.Measurement: After placing at room ambient temperature for 24 hours minimum

2 HUMIDITY RESISTANCE

a.Performance specification

- 1.Appearance: no mechanical damage
- 2.Impedance: within $\pm 30\%$ of initial value
- 3.DC resistance shall be satisfied

b.Test condition

- 1.Humidity: 90 to 95 % RH
- 2.Temperature: $60 \pm 2^{\circ}\text{C}$
- 3.Applied current: Rated current (maximum value)
- 4.Testing time: 1008 ± 12 hours
- 5.Measurement: After placing at room ambient temperature for 24 hours minimum

3 TEMPERATURE CYCLE

a.Performance specification

- 1.Appearance: no mechanical damage
- 2.Impedance: within $\pm 30\%$ of initial value
3. DC resistance shall be satisfied

b.Test condition

- 1.Temperature $-55^{\circ}\text{C}, +125^{\circ}\text{C}$ kept stabilized for 30 minutes each
- 2.Cycle: 100 cycles
- 3.Measurement: After placing for 24 hours minimum at room ambient temperature
4. step1. -55°C temp $\pm 3^{\circ}\text{C}$ 30 ± 3 minutes
step2. Standard atmospheric conditions 5s or less
step3. $+125^{\circ}\text{C}$ temp $\pm 2^{\circ}\text{C}$ 30 ± 3 minutes
step4. Standard atmospheric conditions 5s or less

	东莞市增益实业有限公司 地址: 东莞市塘厦镇林村塘厦大道北552号 电话: 0769-87321000 传真: 0769-87891229	物料类型:	叠层磁珠		
		日期:	2020/11/6		
		版本:	A		
制订	张翔	审核	刘业明	核准	柯文学

RELIABILITY AND TEST CONDITIONS

RELIABILITY AND TEST CONDITIONS

4 LOW TEMPERATURE STORAGE LIFE TEST

a.Performance specification

- 1.Appearance: no mechanical damage
- 2.Impedance shall be with $\pm 30\%$ of the initial value
3. DC resistance shall be satisfied

b.Test condition

- 1.Temperature $-55^{\circ}\text{C}\pm 2^{\circ}\text{C}$
- 2.Testing time: 1008 ± 12 hours
- 3.Measurement: After placing for 24 hours minimum at room ambient temperature

5 THERMAL SHOCK

a.Performance specification

- 1.Appearance: no mechanical damage
- 2.Impedance shall be with $\pm 30\%$ of the initial value

b.Test condition

- 1.Temperature $-55^{\circ}\text{C}, +125^{\circ}\text{C}$ kept stabilized for 30 minutes each
- 2.Cycle: 100 cycles
- 3.Measurement: After placing for 24 hours minimum at room ambient temperature

6 VIBRATION TEST

a.Performance specification

- 1.Appearance: no mechanical damage
- 2.Impedance shall be with $\pm 30\%$ of the initial value

b.Test condition

- 1.Waveform:Sine wave
- 2.Frequency: $10\sim 55\sim 10$ Hz
- 3.Sweep time:1min
- 4.Amplitude:1.5mm(peak-peak)
- 5.Direction:X,Y,Z(3 axes)
- 6.Duration:2 hrs./axis,total 6 hrs.



东莞市增益实业有限公司
地址：东莞市塘厦镇林村塘厦大道北552号
电话：0769-87321000
传真：0769-87891229

物料类型:

叠层磁珠

日期:

2020/11/6

版本:

A

制订

张翔

审核

刘业明

核准

柯文学