

SPECIFICATIONS

RK09K12C0D20

ELECTRICAL

1. Total resistance : 100k Ω \pm 30%
2. Rated power : 0.03 W
3. Rated voltage :
 The rated voltage shall be the voltage of D.C. or A.C. (commercial frequency ,effective value) corresponding to the rated power (dissipation),and be obtained from the following formula. When the obtained rated voltage exceeds the maximum working voltage given in the following, however, the maximum working voltage of the following shall be the rated voltage.

$$E = \sqrt{P \cdot R} \text{ (V)}$$
 Where
 E : Rated voltage (V)
 P : Rated power(dissipation) (W)
 R : Nominal total resistance (Ω)
 Maximum working voltage : 50 V A.C. (A.C. Only).
4. Maximun attenuation level 90 dB min. Insertion loss 0.1dB max.
5. Sliding noise : Less than 100 mV measured by method of JIS C 6443.
6. Insulation resistance : Greater than 100 M Ω measured by D.C. 250V.
7. Withstand voltage: More than 1 minute with an application of A.C. 250 V.
8. Taper : A
9. Gang error : 3 dB max.
to -40dB less than 0dB

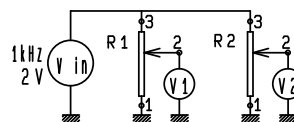

MECHANICAL

1. Overall rotational angle : 280 $^{\circ}$ \pm 5 $^{\circ}$
2. Operation torque : 1~8mN \cdot m
3. Shaft end stop strength : No damage with an application of 0.3N \cdot m.
4. Starting toruque : 20mN \cdot m MAX.
5. Resistance to soldering heat :
 After manual soldering (Less than 350 $^{\circ}$ C and quicker than 3 seconds) there shall be no evidence of poor contact between resistance element and terminals, or any physical damages as a result of the test.
6. Play of shaft :
 The resistor shall be mounted by soldering the mounting legs on the panel. Then a side thrust of 25mN \cdot m at the end of the shaft shall be applied, then the total play of the shaft shall not exceed 0.8 x L / 20 mm p-p.
 (L:Shaft length)
7. Inclination of shaft :
 The inclination of shaft shall be within 0.35mm to the center of shaft, which is parallel to the mounting surface.
8. Eccentricity of shaft :
 The eccentricity of the root of shaft shall not exceed 0.35mm against the center of the mounting position.
10. Robustness of shaft against end thrust :
 The shaft shall withstand against end thrust of 50N for 3 seconds.
11. Robustness of shaft against side thrust :
 The shaft shall withstand against side thrust of 40N for 3 seconds on the end of the shaft at right angles to the axis of the shaft after mounting the resistor by soldering.

ENDURANCE

1. Rotational life : 10,000 cycles min.

NOTE

1. The items except above mentioned items shall meet or exceed JIS C 6443.
2. Operating temperature : -10 $^{\circ}$ C~+70 $^{\circ}$ C. 3. Storage temperature : -30 $^{\circ}$ C~+70 $^{\circ}$ C.

					ALPSALPINE CO.,LTD.			
					APPD.	CHKD.	DSGD.	TITLE
					Aug. 01. '95	Aug. 01. '95	Aug. 01. '95	VR00000014
					S. Aizawa	M. Satoh	Y. Saitoh	DOCUMENT NO.
SYMB	DATE	APPD	CHKD	DSGD				

WX

Confidential

ALPSALPINE CO., LTD.

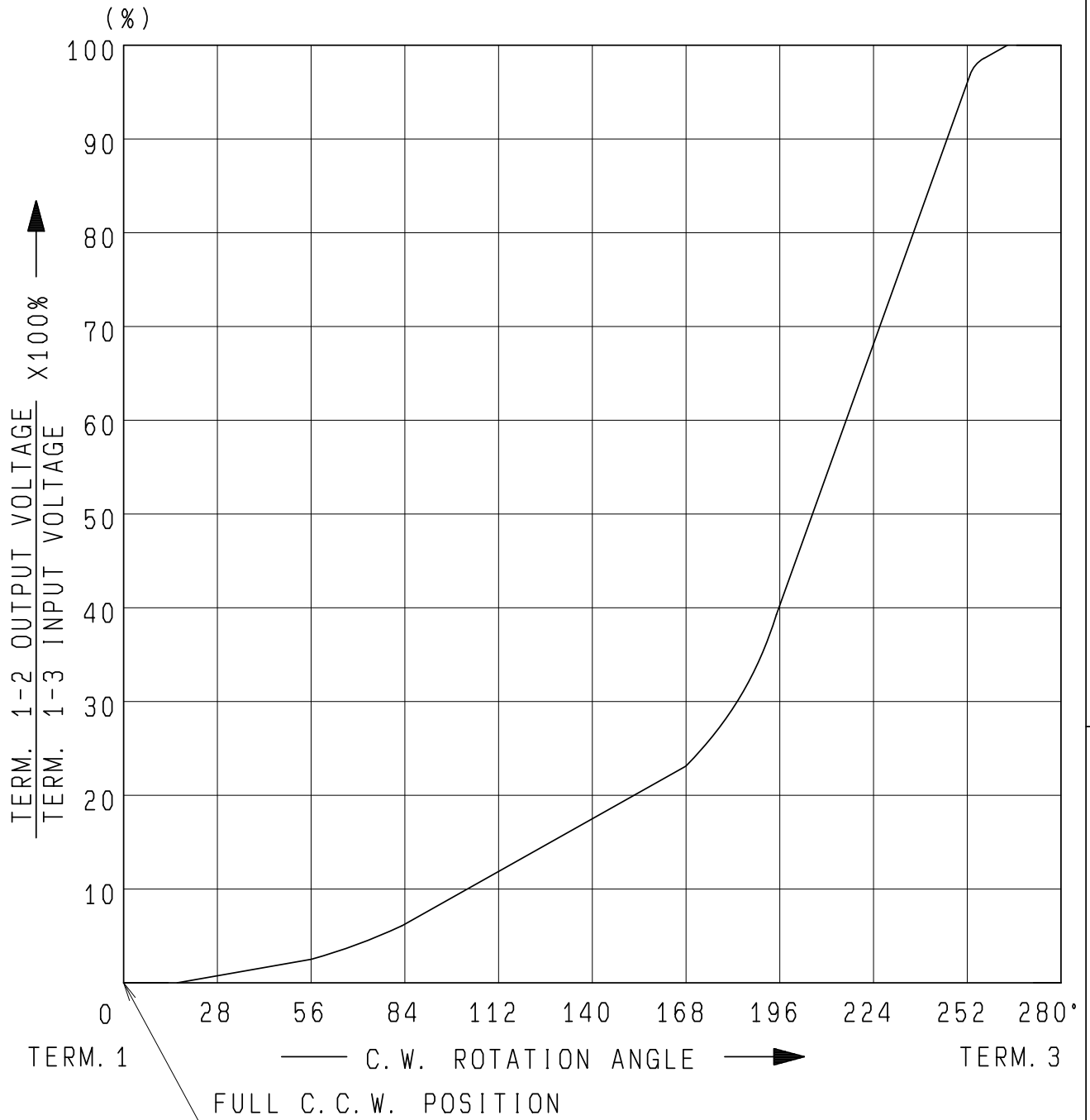

AT 140° C.W. SHAFT ROTATION FROM FULL C.C.W. POSITION VOLTAGE PERCENT SHALL FALL WITHIN THE LIMITS OF 10~25 PERCENT.

					APPD.	CHKD.	DSGD.	NAME (A)
					Jul. 13. '93	Jul. 13. '93	Jul. 13 '93	RESISTANCE TAPER
SYMB	DATE	APPD	CHKD	DSGD	K. Magami	K. Sasaki	K. Suzuki	DOCUMENT NO.
								VR00000014

WX

Confidential

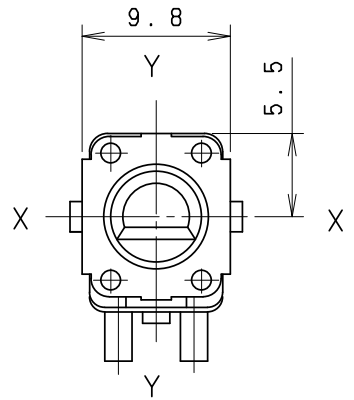
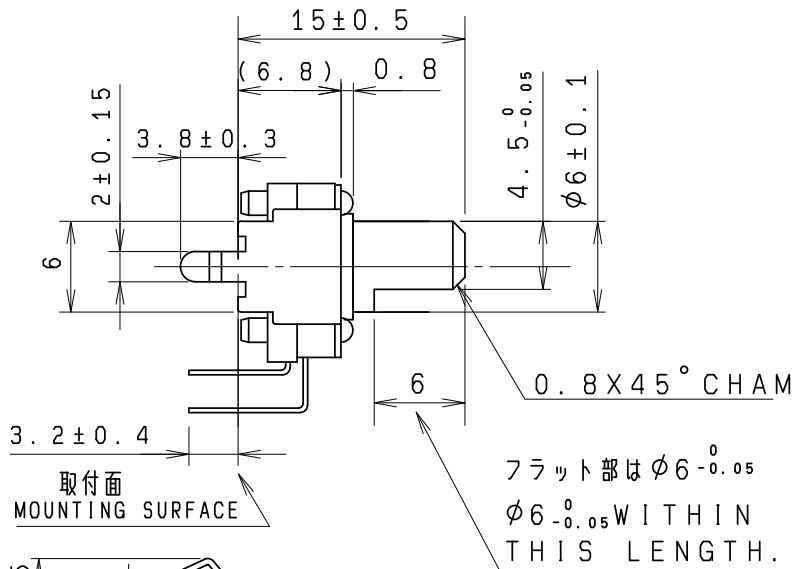

軸はセンター位置を示す。
SHAFT SHOWN IN CENTER POSITION.

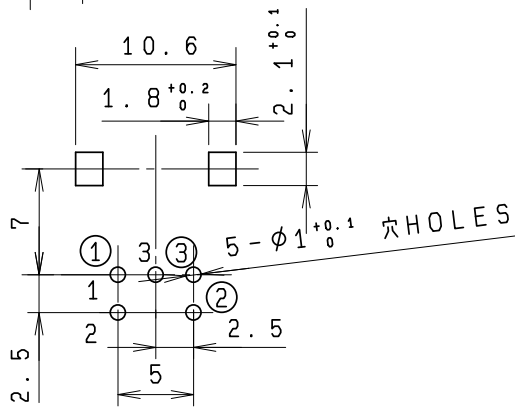
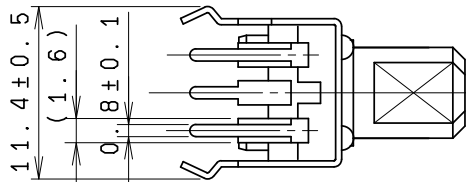

端子取付穴寸法図(挿入側より見た図)
(許容差±0.1)
MOUNTING HOLE DETAIL
(TOLERANCE±0.1)
VIEWED FROM MOUNTING SIDE

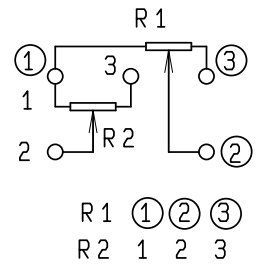
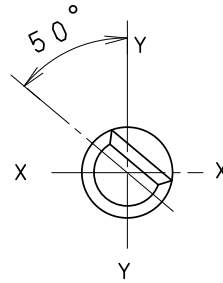

回路図
CIRCUIT

軸は反時計方向に回し切った状態を示す。
SHAFT SHOWN IN FULL C.C.W. POSITION.

指定なき部分の許容差 TOLERANCES UNLESS OTHERWISE SPEC	
$L \leq 10$	±0.3
$10 < L < 100$	±0.5
$100 \leq L$	±0.8
角度 ANGULAR DIMENSION	±5°

PART NO.	NAME	MATERIAL NAME / CODE	FINISH
ALPSALPINE CO., LTD.			
		DSGD. 1-設計1課 Y. Saitoh 95-08-01	SCALE 2 : 1 NO. VR00000014
		CHKD. M. Satoh 95-08-01	TITLE 9形1軸2連絶縁軸VR
		APPD. S. Aizawa 95-08-01	UNIT mm DOCUMENT NO. F01
SYMB	DATE	APPD	CHKD
			DSGD

Confidential