

REV.	MODIFICATION.	DATE	DRN
01	CO2011079	21/02/11	SF
02	CO2011255	18/04/12	SF
03	DIM 8.3 ±0.15 ADDED	25/06/14	NW

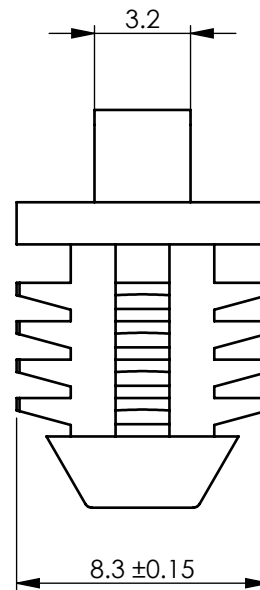
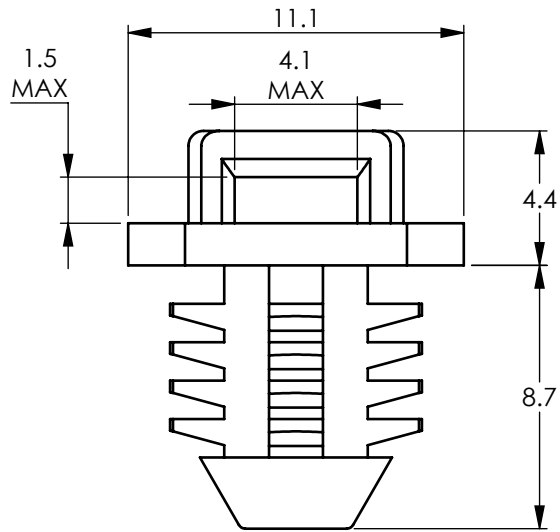
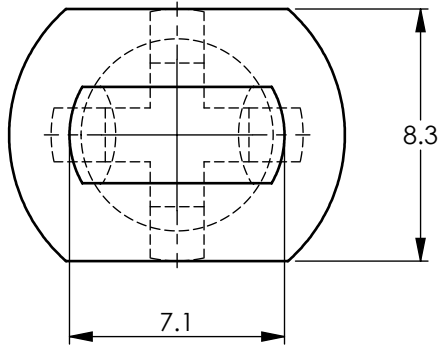

MATERIAL: UL94 V-2 NYLON 6/6, RMS-01* COLOUR: NATURAL		
PART No.	HOLE Ø	PANEL THICKNESS
FTH-15-01-M	7.92±0.08	6.4 MIN.
*AVAILABLE IN UL94 V-0 BY SPECIAL ORDER. TO ORDER REPLACE -01 WITH -19.		

INFORMATION CONTAINED IN THIS DOCUMENT IS CONFIDENTIAL TO RICHCO INTERNATIONAL Co. Ltd. AND MAY NOT BE DISCLOSED OR REPRODUCED IN WHOLE OR PART WITHOUT THEIR WRITTEN CONSENT.

RICHCO, INC.
WWW.RICHCO-INC.COM

ALL DIMENSIONS IN mm
GENERAL TOLERANCES ±0.25
UNLESS OTHERWISE STATED
1 DECIMAL PLACE ±
2 DECIMAL PLACES ±
ANGULAR ±

THIRD ANGLE

MATERIAL: SEE TABLE		COLOUR: SEE TABLE	
DESCRIPTION: FLAT TIE HOLDER		PART No: SEE TABLE	
DRG No: 011-025	PROJECT NUMBER:	SHEET SIZE A4	
DRN SF	DATE 21/02/11	CHKD TC	DATE 18/04/12
SCALE NTS	SHEET No. 1 OF 1		