

GT-TC164X-HXXX-LX

G-SWITCH

Operating Force
 A=60gf
 B=70gf
 C=80gf

Switch Height (mm)
 H055=5.5mm

Switch lifetime (Force)
 L10=1,000,000 Cycles
 L50=5,000,000 Cycles

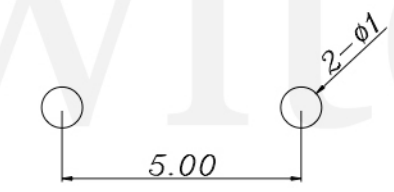
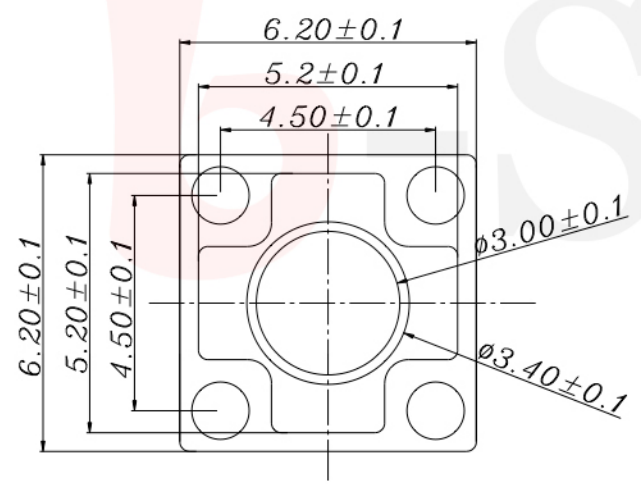

P.C.B LAND DIMENSION

G-Switch Specification:

Operating temperature range : -30°Cto+85°C
 Rating : 50mA.12V DC
 Insulation resistance: : 100MΩ min.100V DC
 Dielectric strength : 250V AC for 1 min
 Contact resistance: : 100m Ω max.
 Travel:0.25±0.1mm

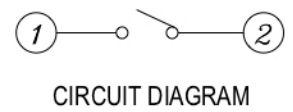

G-Switch Electronic (HongKong) CO.,Ltd.

Unless otherwise specified, Tolerance: X. ±0.30 X.x ±0.20 X.xx ±0.15 X.xxx ±0.10 Angles ±3°	DESIGN FengFengChen	DATE 2019.05.29	Molde code:		
	CHECKED	DATE	GT-TC164X-HXXX-LX		
	APPROVED	DATE			
	http://www.dg-switch.com		REV.: X1	SCALE: 4:1	UNIT: mm
TEL:0769-82388879	SIZE: A4	SHEET: 1/1			