

GT-TC120X-HXXX-LX

G-SWITCH

Operating Force

- A=160gf
- B=250gf
- C=100gf
- D=70gf
- E=130gf
- F=320gf
- G=400gf

Switch lifetime (Force)

- L05=50,000 Cycles
- L1=100,000 Cycles
- L3=300,000 Cycles
- L5=500,000 Cycles

Switch Height (mm)

- H043=4.3 H050=5.0
- H055=5.5 H060=6.0
- H065=6.5 H070=7.0
- H075=7.5 H080=8.0
- H085=8.5 H090=9.0
- H095=9.5 H100=10.0

G-Switch Specification:

Operating temperature range: -30°C to +85°C
 Rating: 50mA, 12V DC
 Insulation resistance: 100MΩ min, 100V DC
 Dielectric strength: 250V AC for 1 min
 Contact resistance: 100mΩ max.
 Travel: 0.25±0.1mm
WATER RESISTANCE: IPX7

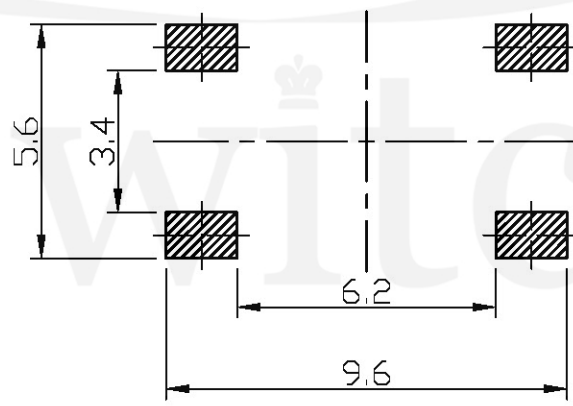
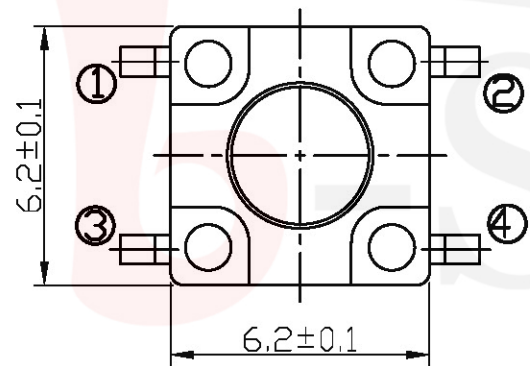

P.C.B LAND DIMENSION

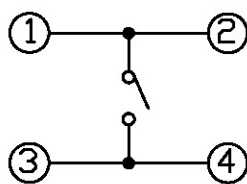

CIRCUIT DIAGRAM



RoHS
Compliant
2002/95/EC



G-Switch Electronic (HongKong) CO.,Ltd.

Unless otherwise specified, Tolerance:
 X. ±0.30
 X.x ±0.20
 X.xx ±0.15
 X.xxx ±0.10
 Angles ±3°

DESIGN FengFengChen DATE 2019.05.29
 CHECKED DATE
 APPROVED DATE
<http://www.dg-switch.com>
 TEL:0769-82388879

Molde code:
GT-TC120X-HXXX-LX
 REV.: X1 SCALE: 4:1 UNIT: mm
 SIZE: A4 SHEET: 1/1