

SK8401 CMOS RF Front-end IC for 2.4GHz ZIGBEE/ISM Transmit/Receive

Description

The SK8401 is a fully integrated, single-chip RF Front-end IC which incorporates all the RF functionality needed for IEEE 802.15.4/ZigBee, wireless sensor network, and any other wireless systems in the 2.4GHz ISM band. The SK8401 integrates the PA, LNA Transmit and Receive switching circuitry in one CMOS single-chip device.

Typical high power applications include home and industrial automation, smart power, and RF4CE among others. Combining superior performance, high sensitivity and efficiency, low noise, small form factor, and low cost, SK8401 is the perfect solution for applications requiring extended range and bandwidth. SK8401 has simple and low-voltage CMOS control logic, and requires minimal external components for system implementation.

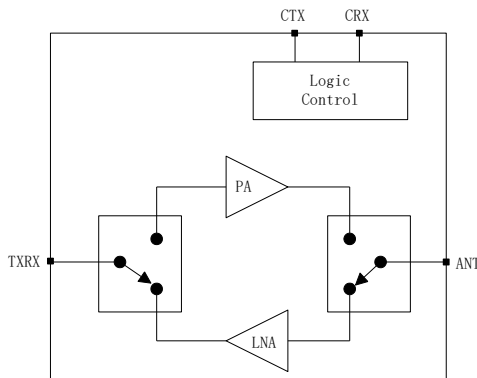

Pin Description

Name	Pin	Description
TXRX	4	RF signal to/from the transceiver
TXEN	5	CMOS input to control TX enable
RXEN	6	CMOS input to control RX enable
ANT	10	Connect to 50 Ω antenna
VDD	14,16	Voltage supply connection
GND	2,3,8,9,11	Ground
DNC	13	Do not connect
NC	1,7,12,15	Not connected

Applications

- ZigBee Extended Range Devices
- Home and Industrial Automation
- ZigBee Smart Power
- RF4CE Remote Control
- Mobile and Battery ZigBee Systems
- Custom 2.4GHz Radio Systems

Features

- 2.4 GHz high-power single-chip, single-die RF front-end IC
- Single-ended 50 Ω input and output ports
- Integrated PA with up to +22.5 dBm output power
- Integrated LNA with 3 dB noise figure
- Transmit/receive switch circuitry
- ESD protection circuitry on all ports
- DC decoupled RF ports
- Full on-chip matching and decoupling circuitry
- Market proven CMOS technology
- QFN 16 (3 x 3 x 0.75 mm) package with

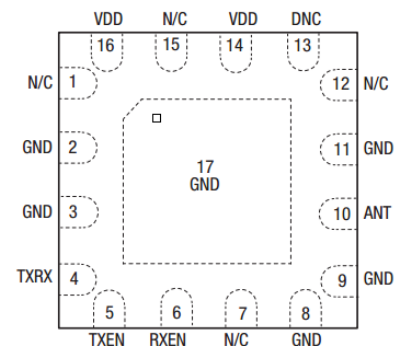

SK8401 Pinout (Top view)

Absolute Maximum Ratings

Parameter	Specification		Unit	Condition
	Min	Max		
Supply Voltage VDD	0	4	V	
DC control voltage	0	3.6	V	Through 1kOhm resistor
DC VDD current consumption		350	mA	Through VDD pins when TXEN is on
Sleep current consumption		0.5	uA	
RF input power		5	dBm	
ESD (HBM)		+8000	V	
Junction Temperature		+150	°C	

Recommended Operating Condition

Parameter	Specification			Unit	Condition
	Min	Typ	Max		
Supply voltage VDD	3	3.3	3.6	V	All VDD pins
Control voltage "high"	1.2		VDD		Through 1kOhm resistor
Control voltage "low"	0		0.3		Through 1kOhm resistor
Ambient Temperature	-40	25	+125	°C	

SK8401 Control Logic

Mode	TXEN	RXEN
TX active	1	X
RX active	0	1
Shutdown	0	0

"1" denotes high voltage state (> 1.2 V)

"0" denotes low voltage stage (< 0.3 V) at control pins

"X" denotes do not care: either "1" or "0" can be applied

Electrical Specifications (VDD=3.3V, 25°C, Frequency=2.4GHz-2.5GHz)

Parameter	Specification Typical Value	Unit	Condition
TX			
Gain	25	dB	
Quiescent Current	22	mA	
Saturated Output Power	+22.5	dBm	
Output Current	98	mA	Pout=20 dBm at ANT
Input Return Loss	-11	dB	
Output Return Loss	-7	dB	
Input / output impedance	50	Ohm	Single-ended
Second Harmonic	-13	dBm/MHz	Pout=20 dBm at ANT
Third Harmonic	-20	dBm/MHz	Pout=20 dBm at ANT
Load VSWR for stability	6:1	N/A	Pout= +20 dBm
Load VSWR for ruggedness	No damage	N/A	Pout=+20 dBm
RX			
Small-Signal Gain	15	dB	
Noise Figure	2.9	dB	
Input P1dB	-4	dBm	
Input Return Loss	-11	dB	
Output Return Loss	-12	dB	
Quiescent Current	9	mA	
ESD	>8000	V	

Package Dimensions

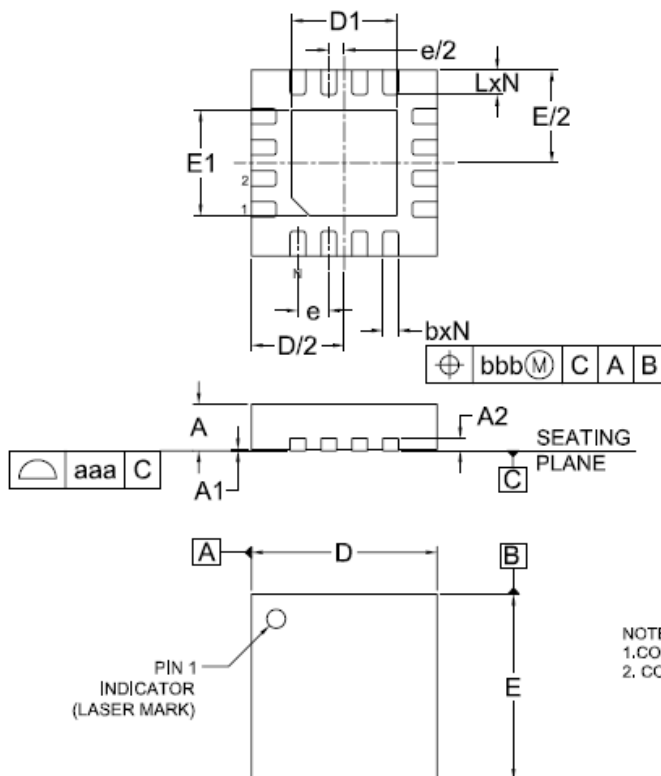

COMMON DIMENSIONS
(UNITS OF MEASURE=MILLIMETER)

SYMBOL	MIN	TYP	MAX
A	0,70	0,75	0,80
A1	0,00	0,02	0,05
A2		0,20	
b	0,18	0,25	0,30
D	2,90	3,00	3,10
D1	1,55	1,70	1,80
E	2,90	3,00	3,10
E1	1,55	1,70	1,80
e		0,5BSC	
L	0,30	0,40	0,50
N		16	
aaa		0,08	
bbb		0,10	

NOTES:
1. CONTROLLING DIMENSIONS ARE IN MILLIMETERS (ANGLES IN DEGREES).
2. COPLANARITY APPLIES TO THE EXPOSED PAD AS THE TERMINALS.