



PJM3401PSC

P-Channel Power MOSFET

Features

- $V_{DS} = -30V$ $I_D = -4.5A$
- $R_{DS(ON)} = 60m\Omega(\text{max}) @ -10V$
- Halogen and Antimony Free

Applications

- Load Switch and in PWM Applications

SOT-23-3

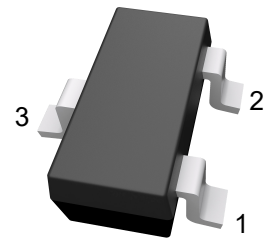

1. Gate 2. Source 3. Drain

Marking: P1

Schematic Diagram

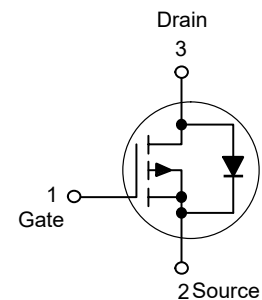

Absolute Maximum Ratings

Ratings at $T_A = 25^\circ\text{C}$ unless otherwise specified.

Parameter	Symbol	Value	Units
Drain-Source Voltage	$-V_{DS}$	30	V
Gate-Source Voltage	V_{GS}	± 12	V
Continuous Drain Current	$-I_D$	4.5	A
Power Dissipation	P_D	1.4	W
Junction and Storage Temperature Range	T_J, T_{STG}	150, -55 to 150	$^\circ\text{C}$
Thermal Characteristics			
Parameter	Symbol	Typ.	Units
Maximum Junction-to-Ambient ^{Note1}	$R_{\theta JA}$	89	$^\circ\text{C/W}$



Electrical Characteristics ($T_C=25^\circ\text{C}$ unless otherwise specified)

Parameter	Symbol	Test Condition	Min.	Typ.	Max.	Units
Static Characteristics						
Drain-source breakdown voltage	$-V_{(BR)DSS}$	$V_{GS} = 0V, I_D = -250\mu A$	30	--	--	V
Drain to Source Leakage Current	$-I_{DSS}$	$V_{DS} = -30V, V_{GS} = 0V$	--	--	1	μA
Gate-body leakage current	I_{GSS}	$V_{GS} = \pm 12V, V_{DS} = 0V$	--	--	± 100	nA
Gate threshold voltage ^{Note2}	$-V_{GS(th)}$	$V_{DS} = V_{GS}, I_D = -250\mu A$	0.7	1	1.3	V
Drain-source on-resistance ^{Note2}	$R_{DS(on)}$	$V_{GS} = -10V, I_D = -4.1A$	--	--	60	m Ω
		$V_{GS} = -4.5V, I_D = -4A$	--	--	70	m Ω
		$V_{GS} = -2.5V, I_D = -1A$	--	--	90	m Ω
Forward transconductance ^{Note2}	g_{FS}	$V_{DS} = -5V, I_D = -5A$	7	--	--	S
Dynamic characteristics						
Input Capacitance	C_{iss}	$V_{DS} = -15V, V_{GS} = 0V, f = 1MHz$	--	880	--	pF
Output Capacitance	C_{oss}		--	105	--	
Reverse Transfer Capacitance	C_{rss}		--	65	--	
Switching Characteristics						
Turn-on delay time	$t_{d(on)}$	$V_{DS} = -15V,$ $V_{GS} = -10V, R_{GEN}$ $= 6\Omega, I_D = -4.2A$	--	7	--	ns
Turn-on rise time	t_r		--	3	--	
Turn-off delay time	$t_{d(off)}$		--	30	--	
Turn-off fall time	t_f		--	12	--	
Total gate charge	Q_g	$V_{DD} = -15V, V_{GS} = -4.5V, I_D = -4.2A$	--	8.5	--	nC
Gate-source charge	Q_{gs}		--	1.8	--	
Gate-drain charge	Q_{gd}		--	2.7	--	
Source-Drain Diode characteristics						
Diode Forward voltage	$-V_{DS}$	$V_{GS} = 0V, I_S = -4.2A$	--	--	1.2	V

Notes:

1. Surface mounted on FR4 board, $t \leq 10$ sec.
2. Pulse Test: Pulse Width $\leq 300\mu s$, Duty Cycle $\leq 2\%$.



Typical Characteristic Curves

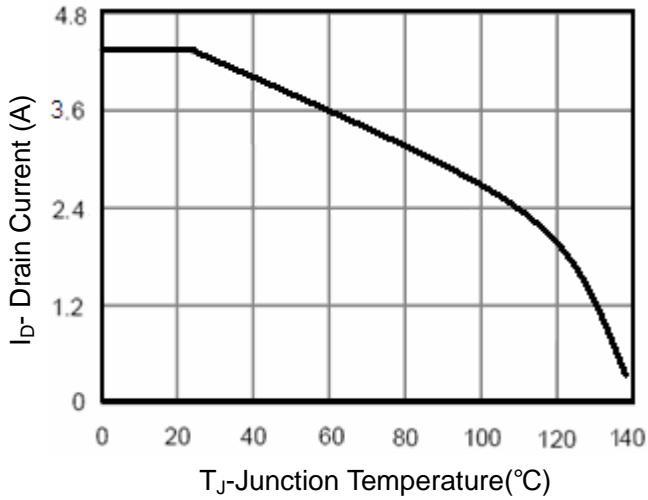

Figure 1 Drain Current

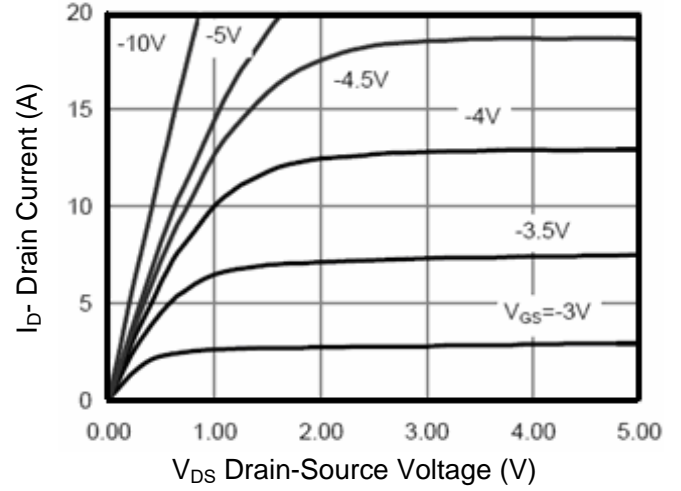

Figure 2 Output Characteristics

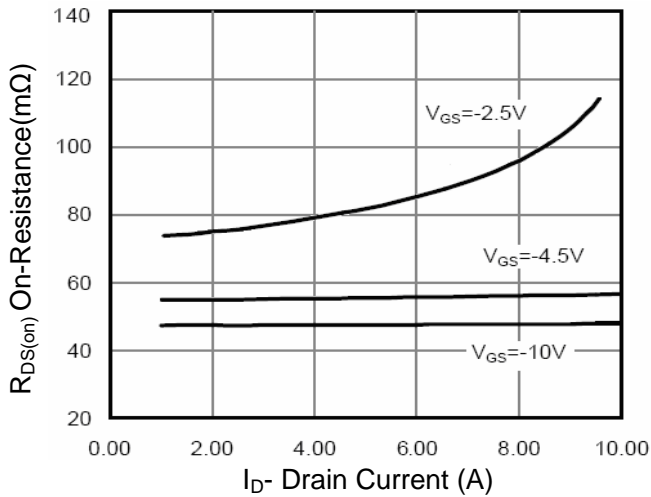

Figure 3 Drain-Source On-Resistance

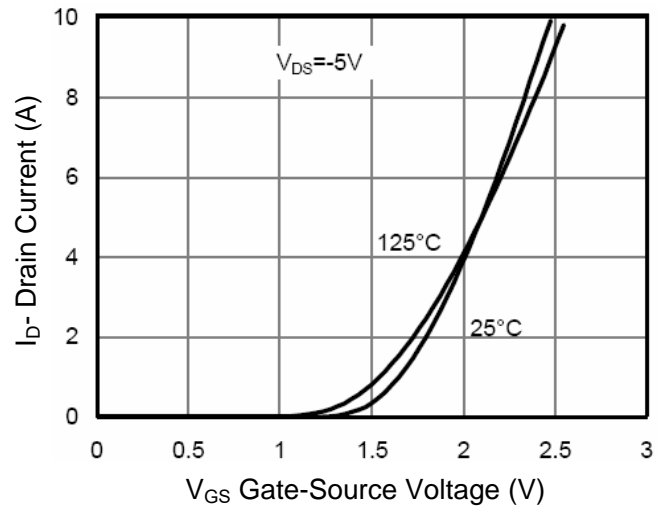

Figure 4 Transfer Characteristics

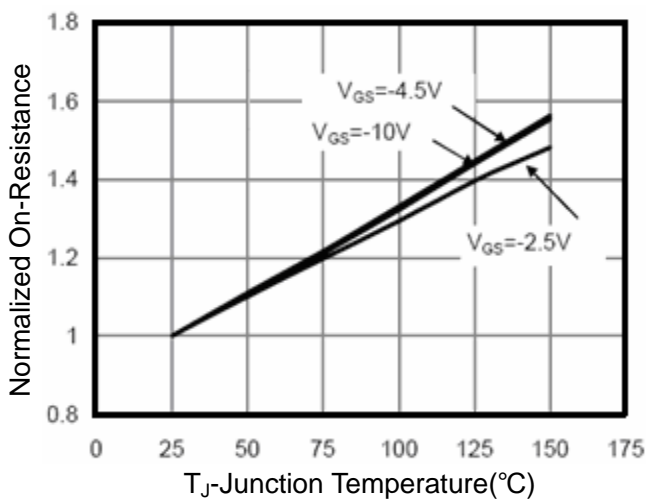

Figure 5 Drain-Source On-Resistance

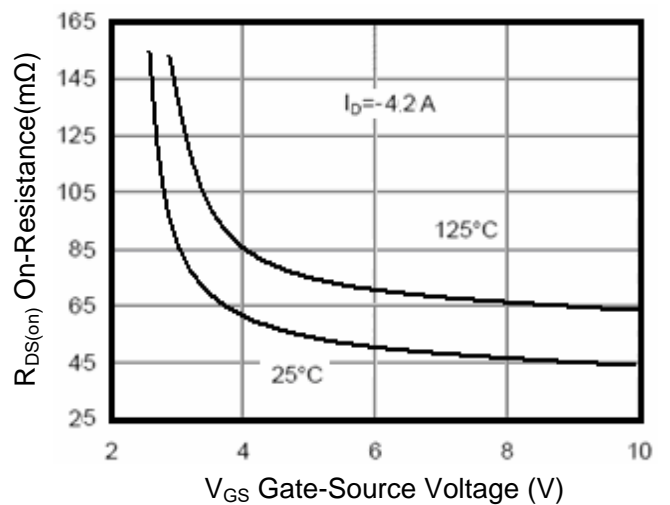

Figure 6 $R_{DS(on)}$ vs V_{GS}

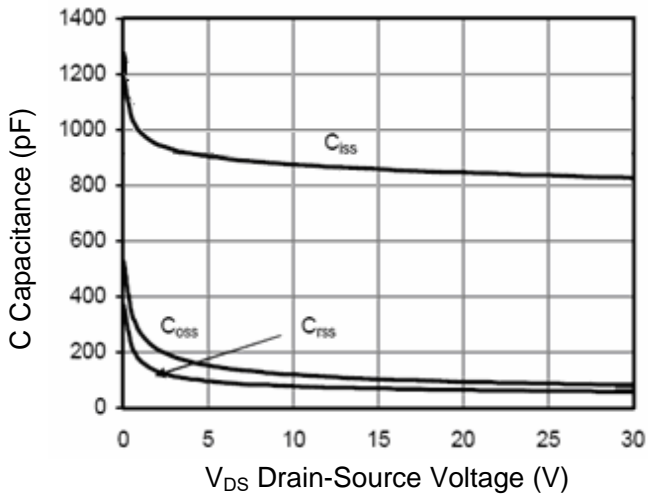

Figure 7 Capacitance vs V_{DS}

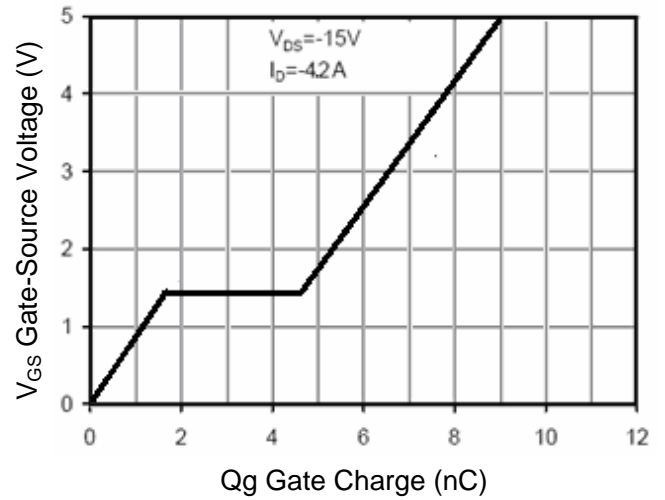

Figure 8 Gate Charge

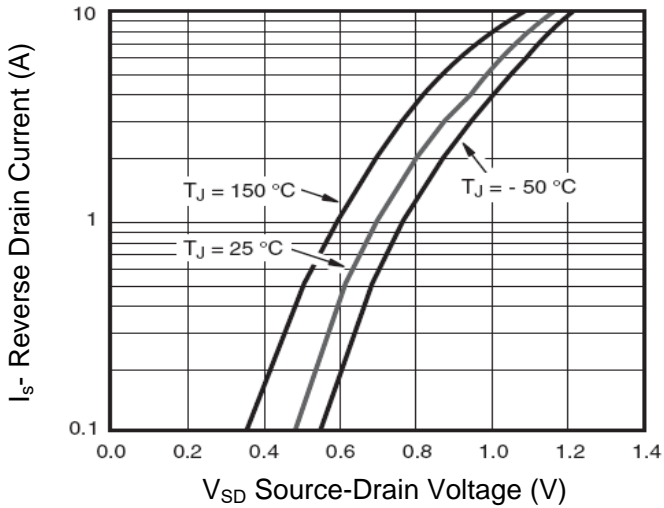

Figure 9 Source- Drain Diode Forward

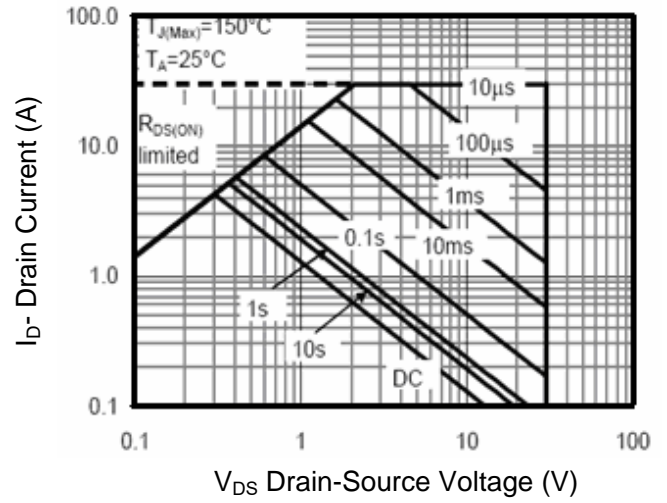

Figure 10 Safe Operation Area



Package Outline

SOT-23-3

Dimensions in mm

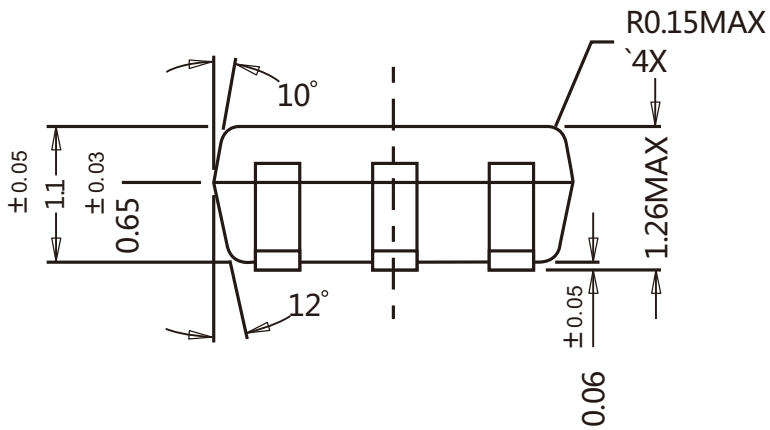
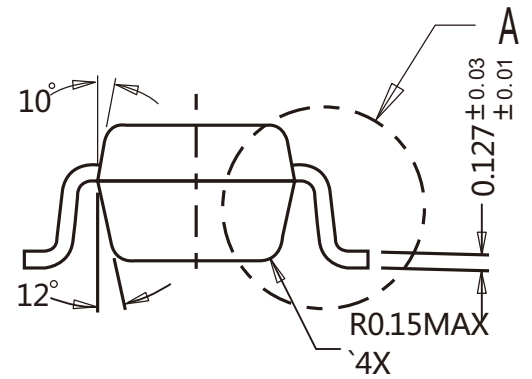
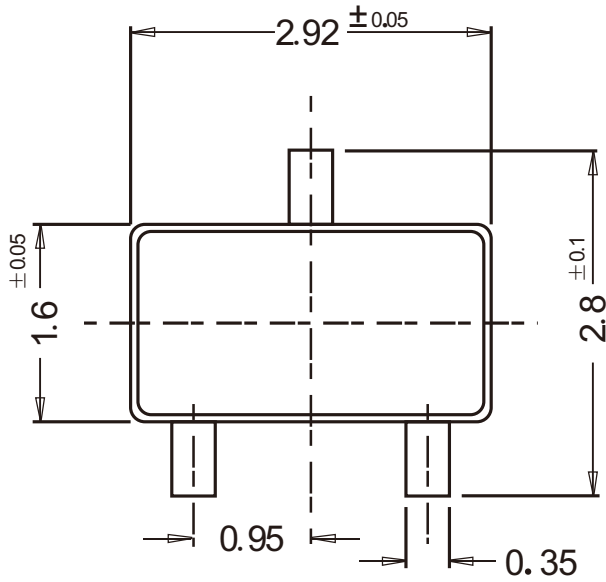

Ordering Information

Device	Package	Shipping
PJM3401PSC	SOT-23-3	3000PCS/Reel&Tape



Conditions of Soldering And Storage

◆ Recommended condition of reflow soldering

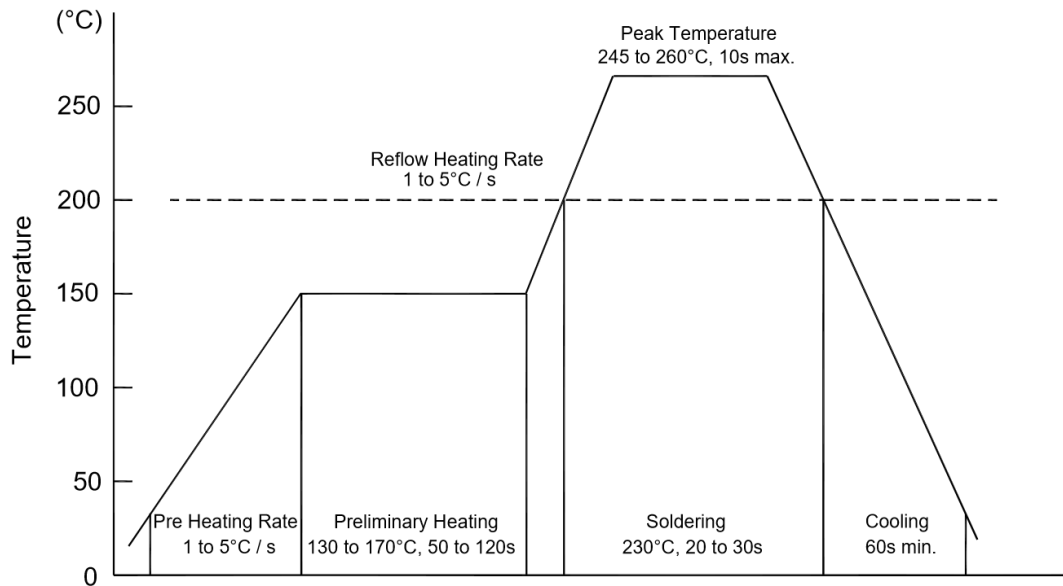

Recommended peak temperature is over 245 °C. If peak temperature is below 245 °C, you may adjust the following parameters:

- Time length of peak temperature (longer)
- Time length of soldering (longer)
- Thickness of solder paste (thicker)

◆ Conditions of hand soldering

- Temperature: 370 °C
- Time: 3s max.
- Times: one time

◆ Storage conditions

- **Temperature**
5 to 40 °C
- **Humidity**
30 to 80% RH
- **Recommended period**
One year after manufacturing



Package Specifications

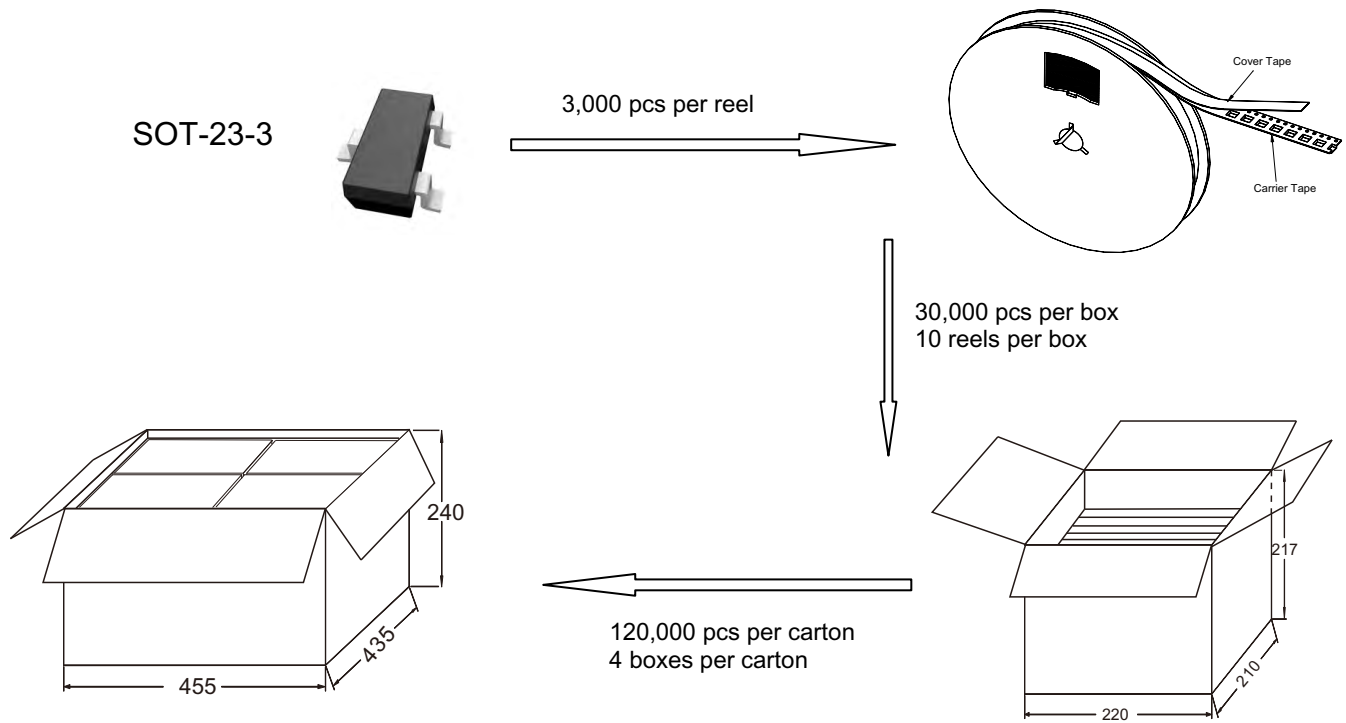

2. Tape and reel data(7inch Units:mm)

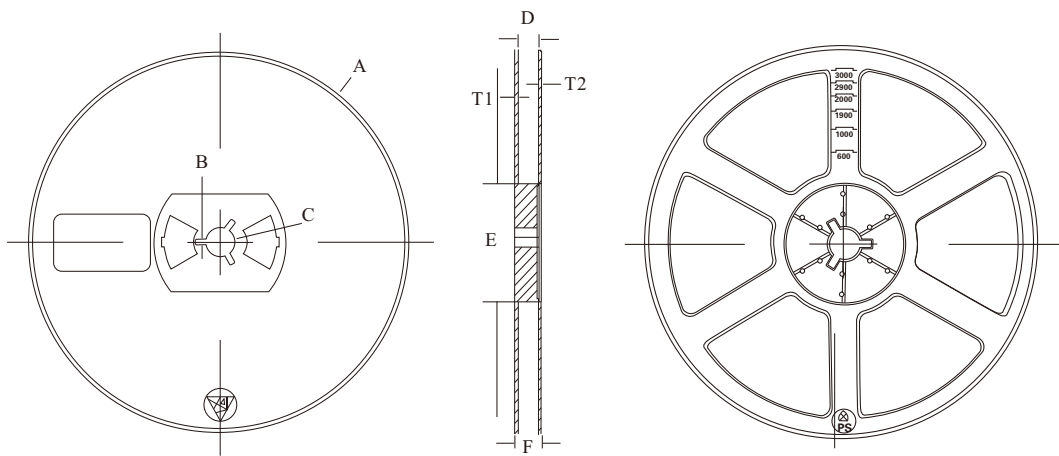

Reel (7")

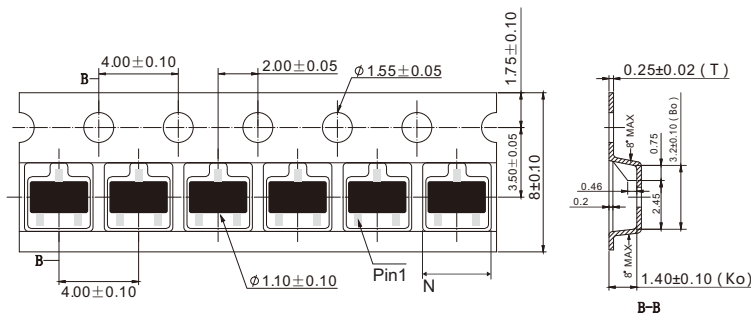

Tape (8mm)

Symbol	Value (unit: mm)
A	Ø 177.8±1
B	2.7±0.2
C	Ø 13.5±0.2
E	Ø 54.5±0.2
F	12.3±0.3
D	9.6+2/-0.3
T1	1.0±0.2
T2	1.2±0.2
N	3.15±0.1
G	1.22±0.1