

Features

- 650-Volt Schottky Rectifier
- Zero Reverse Recovery Current
- Zero Forward Recovery Voltage
- High-Frequency Operation
- Temperature-Independent Switching Behavior
- Extremely Fast Switching
- Positive Temperature Coefficient on V_F

Benefits

- Replace Bipolar with Unipolar Rectifiers
- Essentially No Switching Losses
- Higher Efficiency
- Reduction of Heat Sink Requirements
- Parallel Devices Without Thermal Runaway

Applications

- Solar Inverters
- Motor Drives
- EV Chargers
- UPS
- Automotive

Package

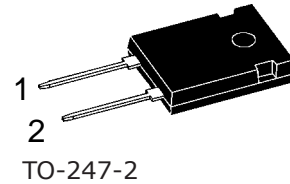

Maximum Ratings ($T_C = 25^\circ\text{C}$ unless otherwise specified)

Symbol	Parameter	Value	Unit	Test Conditions	Note
V_{RRM}	Repetitive Peak Reverse Voltage	650	V		
V_{RSM}	Surge Peak Reverse Voltage	650	V		
V_{DC}	DC Peak Blocking Voltage	650	V		
I_F	Continuous Forward Current	100 50 46	A	$T_C=25^\circ\text{C}$ $T_C=130^\circ\text{C}$ $T_C=135^\circ\text{C}$	Fig. 3
I_{FRM}	Repetitive Peak Forward Surge Current	153 106	A	$T_C=25^\circ\text{C}, t_p=10\text{ ms}, \text{Half Sine Pulse}$ $T_C=110^\circ\text{C}, t_p=10\text{ ms}, \text{Half Sine Pulse}$	
I_{FSM}	Non-Repetitive Forward Surge Current	400 330	A	$T_C=25^\circ\text{C}, t_p=10\text{ ms}, \text{Half Sine Pulse}$ $T_C=110^\circ\text{C}, t_p=10\text{ ms}, \text{Half Sine Pulse}$	Fig. 8
$I_{F,Max}$	Non-Repetitive Peak Forward Current	2000 1600	A	$T_C=25^\circ\text{C}, t_p=10\text{ }\mu\text{s}, \text{Pulse}$ $T_C=110^\circ\text{C}, t_p=10\text{ }\mu\text{s}, \text{Pulse}$	Fig. 8
P_{tot}	Power Dissipation	300 130	W	$T_C=25^\circ\text{C}$ $T_C=110^\circ\text{C}$	Fig. 4
$\int i^2 dt$	i^2t value (Per Leg)	800 545	A ² s	$T_C=25^\circ\text{C}, t_p=10\text{ ms}$ $T_C=110^\circ\text{C}, t_p=10\text{ ms}$	
T_J, T_{stg}	Operating Junction and Storage Temperature	-55 to +175	$^\circ\text{C}$		
	TO-247 Mounting Torque	1 8.8	Nm lbf-in	M3 Screw 6-32 Screw	

Electrical Characteristics

Symbol	Parameter	Typ.	Max.	Unit	Test Conditions	Note
V_F	Forward Voltage	1.5	1.8	V	$I_F = 50\text{ A}, T_J = 25^\circ\text{C}$ $I_F = 25\text{ A}, T_J = 25^\circ\text{C}$	Fig. 1
		1.8	2.2			
I_R	Reverse Current	50	500	μA	$V_R = 650\text{ V}, T_J = 25^\circ\text{C}$ $V_R = 400\text{ V}, T_J = 25^\circ\text{C}$	Fig. 2
		200	1000			
Q_C	Total Capacitive Charge	110		nC	$V_R = 400\text{ V}, I_F = 50\text{ A}$ $di/dt = 500\text{ A}/\mu\text{s}$ $T_J = 25^\circ\text{C}$	Fig. 5
C	Total Capacitance	1970		pF	$V_R = 0\text{ V}, T_J = 25^\circ\text{C}, f = 1\text{ MHz}$ $V_R = 200\text{ V}, T_J = 25^\circ\text{C}, f = 1\text{ MHz}$ $V_R = 400\text{ V}, T_J = 25^\circ\text{C}, f = 1\text{ MHz}$	Fig. 6
		200				
		180				
E_C	Capacitance Stored Energy	16.5		μJ	$V_R = 400\text{ V}$	Fig. 7

Note: This is a majority carrier diode, so there is no reverse recovery charge.

Thermal Characteristics

Symbol	Parameter	Typ.	Unit
$R_{\theta JC}$	Thermal Resistance from Junction to Case	0.5	$^\circ\text{C}/\text{W}$

Typical Performance

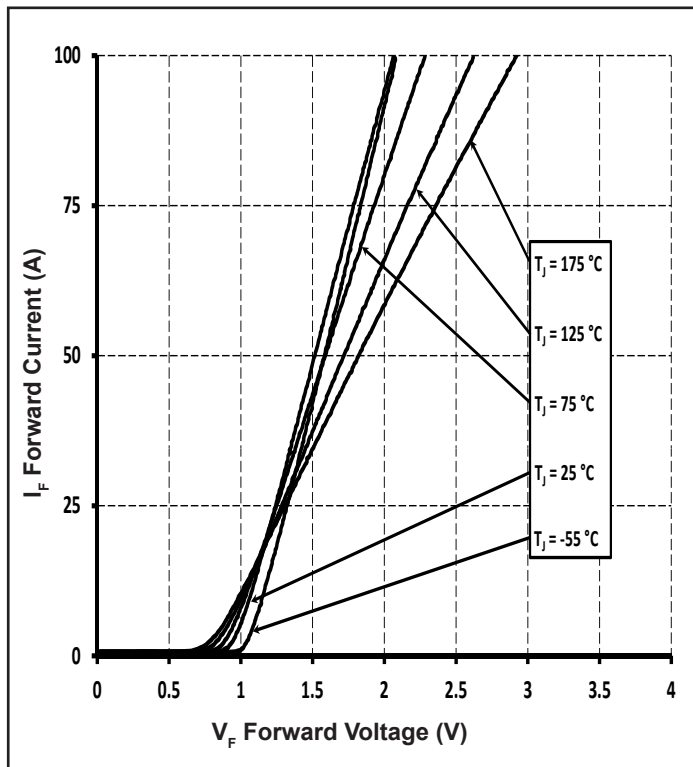

Figure 1. Forward Characteristics

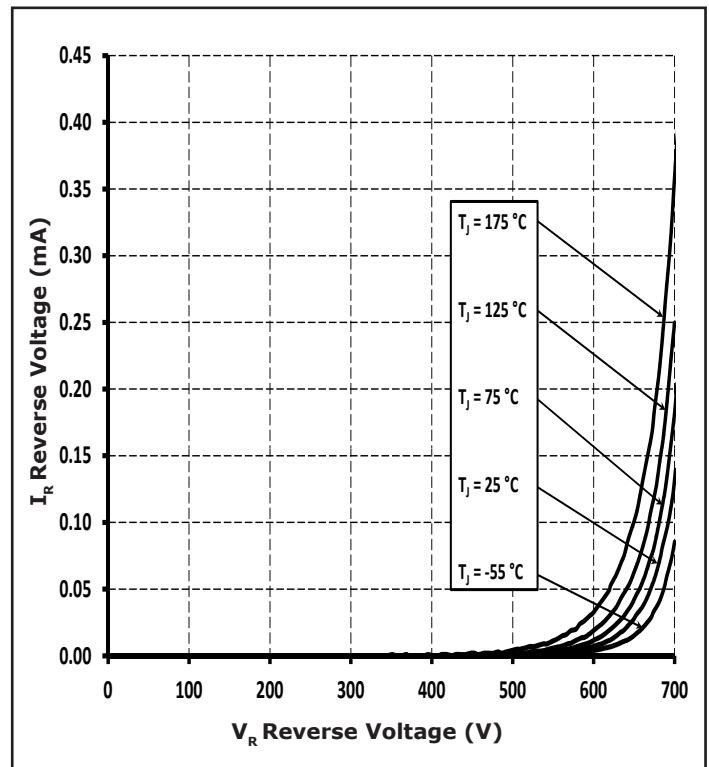

Figure 2. Reverse Characteristics

Typical Performance

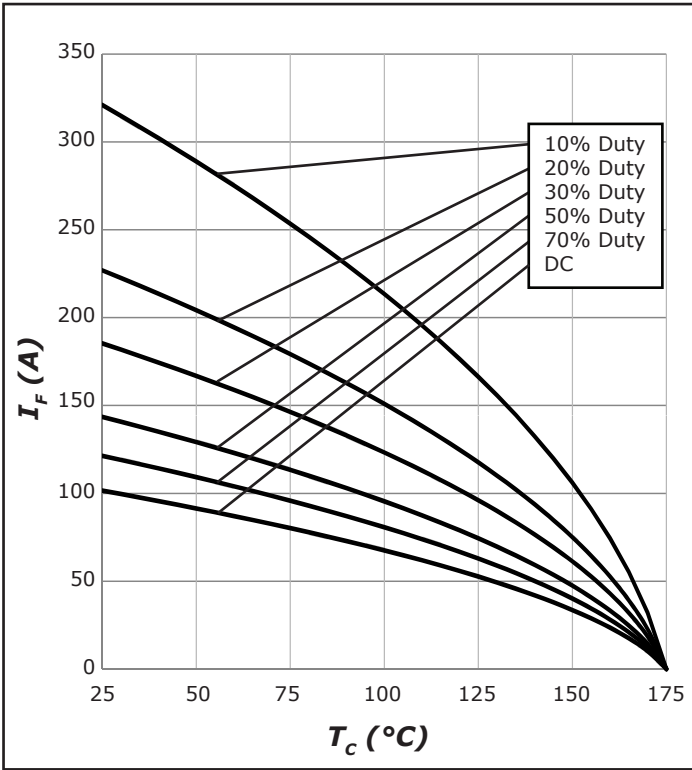

Figure 3. Current Derating

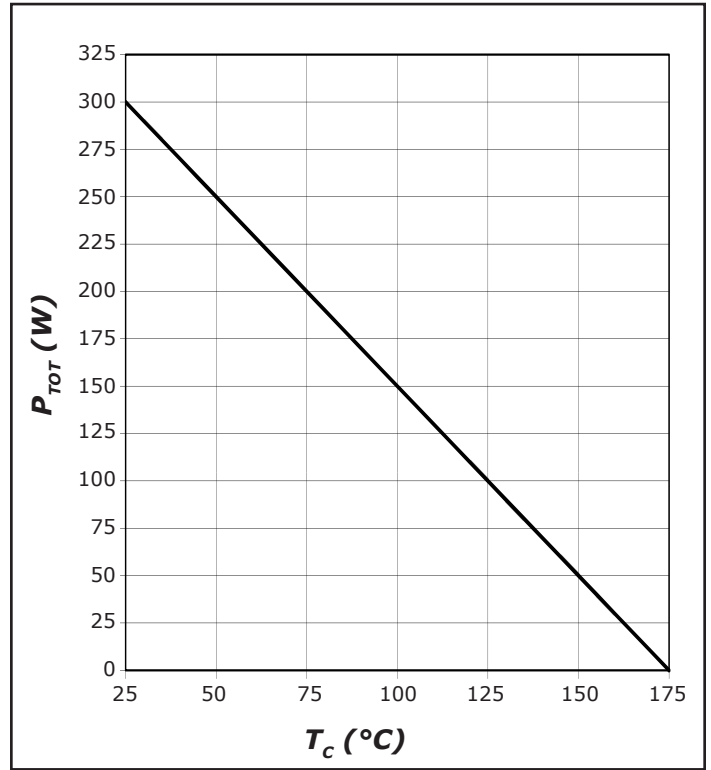

Figure 4. Power Derating

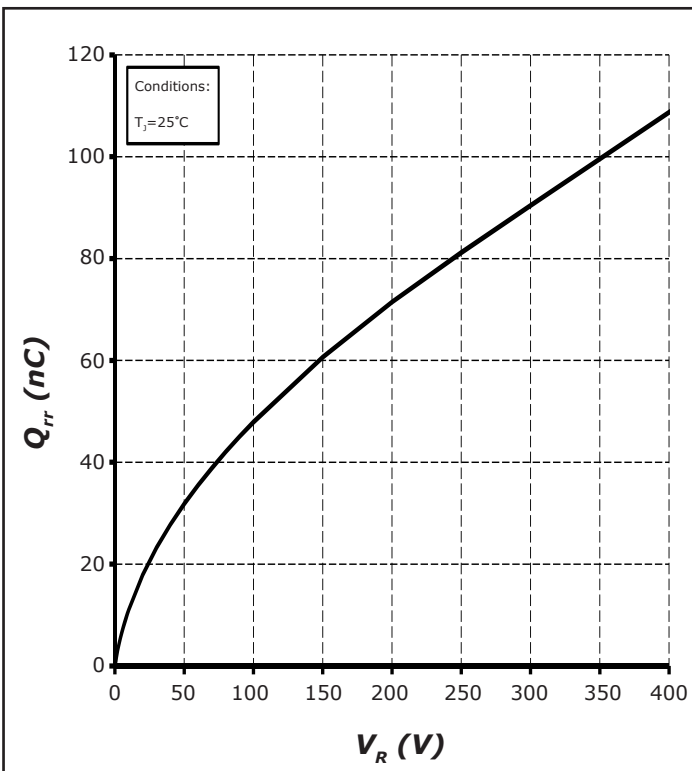

Figure 5. Recovery Charge vs. Reverse Voltage

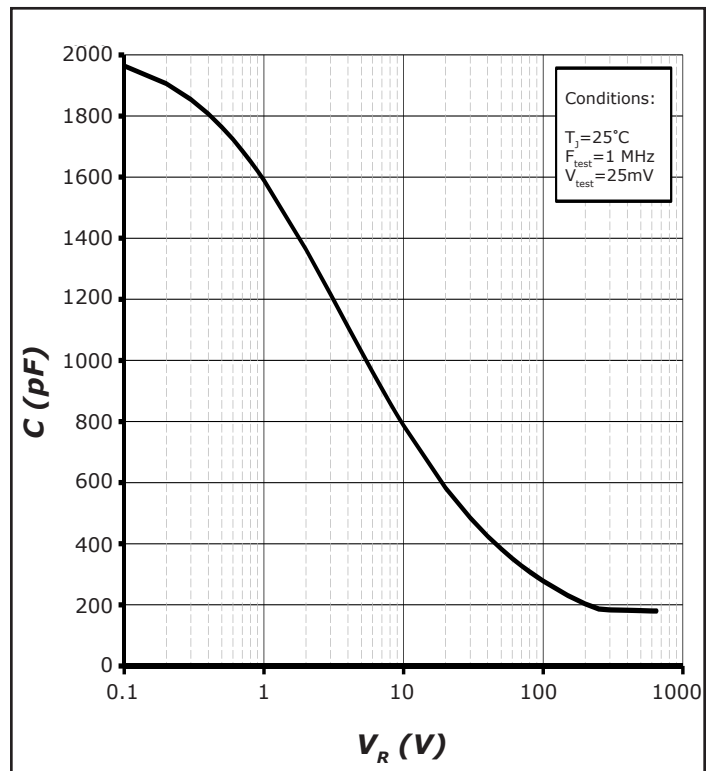

Figure 6. Typical Capacitance vs. Reverse Voltage

Typical Performance

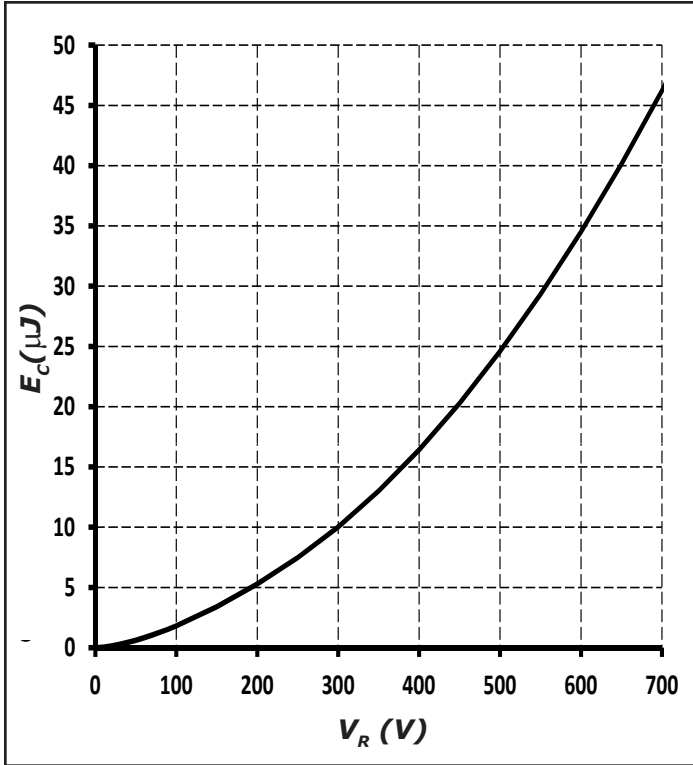

Figure 7. Typical Capacitance Stored Energy

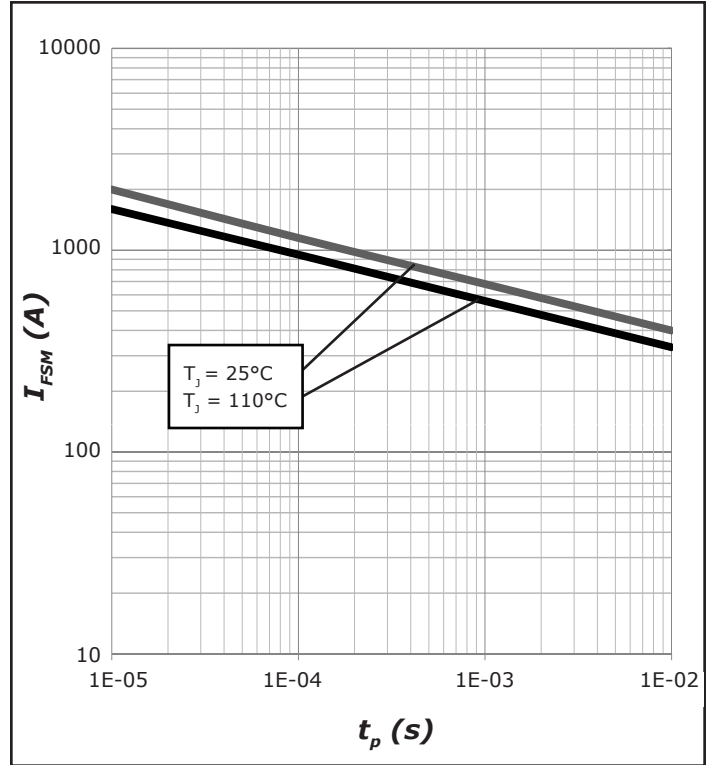

Figure 8. Non-Repetitive Peak Forward Surge Current versus Pulse Duration (sinusoidal waveform)

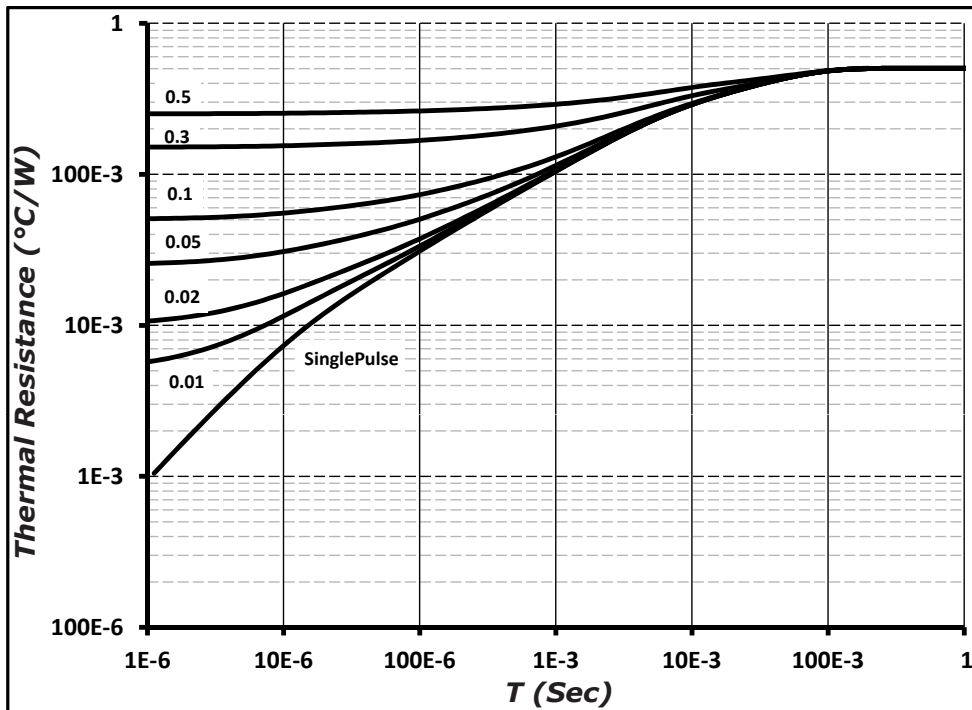
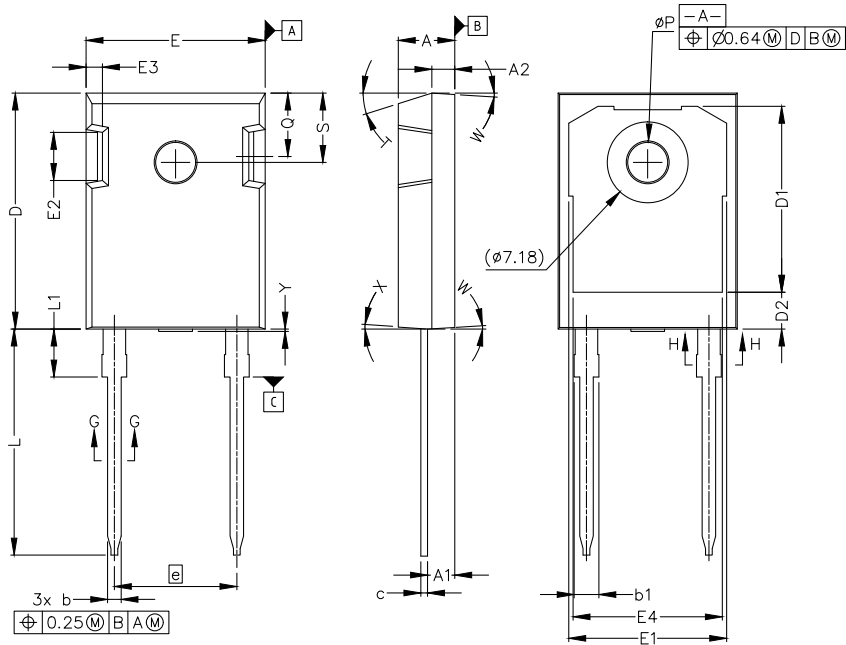

Figure 9. Transient Thermal Impedance

Package Dimensions: TO247-2L



POS	Inches		Millimeters	
	Min	Max	Min	Max
A	0.190	0.205	4.70	5.31
A1	0.087	0.102	2.21	2.59
A2	0.059	0.098	1.50	2.49
b	0.039	0.055	0.99	1.40
b1	0.065	0.095	1.65	2.41
c	0.015	0.035	0.38	0.89
D	0.819	0.845	20.80	21.46
D1	0.640	0.683	16.25	17.35
D2	0.112	0.124	2.86	3.16
E	0.620	0.640	15.49	16.26
E1	0.516	0.557	13.10	14.15
E2	0.135	0.201	3.43	5.10
E3	0.039	0.075	1.00	1.90
E4	0.487	0.529	12.38	13.43
e	0.428 BSC		10.88 BSC	
L	0.78	0.80	19.81	20.32
L1	-	0.177	-	4.50
ØP	0.138	0.144	3.51	3.66
Q	0.212	0.244	5.38	6.20
S	0.238	0.248	6.04	6.3
T	17.5° REF.			
W	3.5° REF.			
X	4° REF.			
Y	0	0.5	0	0.02