

1A, 1.2 MHz PWM Boost Converter in Thin SOT23 and DFN Packages

Features

- 2.5V to 10V Input Voltage Range
- Output Voltage Adjustable to 34V
- Over 1A Switch Current
- 1.2 MHz PWM Operation
- Stable with Ceramic Capacitors
- <1% Line and Load Regulation
- Low Output Voltage Ripple
- <1 μ A Shutdown Current
- Undervoltage Lockout
- Output Overvoltage Protection (MIC2288YML)
- Overtemperature Shutdown
- Thin 5-Lead SOT23 Package Option
- 2 mm x 2 mm Leadless 8-Lead DFN Package Option
- -40°C to +125°C Junction Temperature Range

Applications

- Organic EL Power Supply
- TFT-LCD Bias Supply
- 12V Supply for DSL Applications
- Multi-Output DC/DC Converters
- Positive and Negative Output Regulators
- SEPIC Converters

Package Types

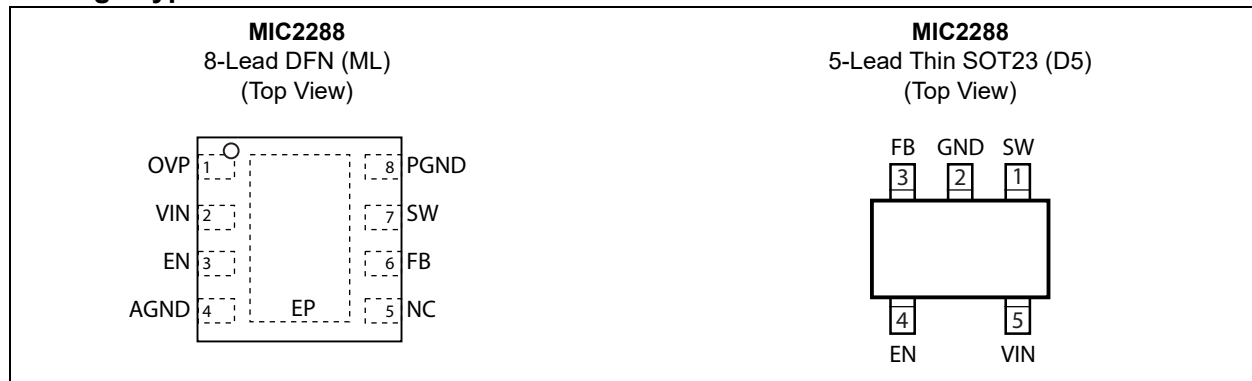

General Description

The MIC2288 is a 1.2 MHz PWM, DC/DC boost switching regulator available in low profile Thin SOT23 and 2 mm x 2 mm DFN package options. High-power density is achieved with the MIC2288 device's internal 34V/1A switch, allowing it to power large loads in a tiny footprint.

The MIC2288 implements a constant frequency, 1.2 MHz PWM, Current-mode control scheme with internal compensation that offers excellent transient response and output regulation performance. The high-frequency operation saves board space by allowing small, low profile, external components. The fixed frequency PWM topology also reduces spurious switching noise and ripple to the input power source.

The MIC2288 is available in a low profile 5-lead Thin SOT23 package and a 2 mm x 2 mm 8-lead DFN leadless package. The DFN package option has an output overvoltage protection feature.

The MIC2288 has a junction temperature range of -40°C to +125°C.

MIC2288

Typical Application Circuit

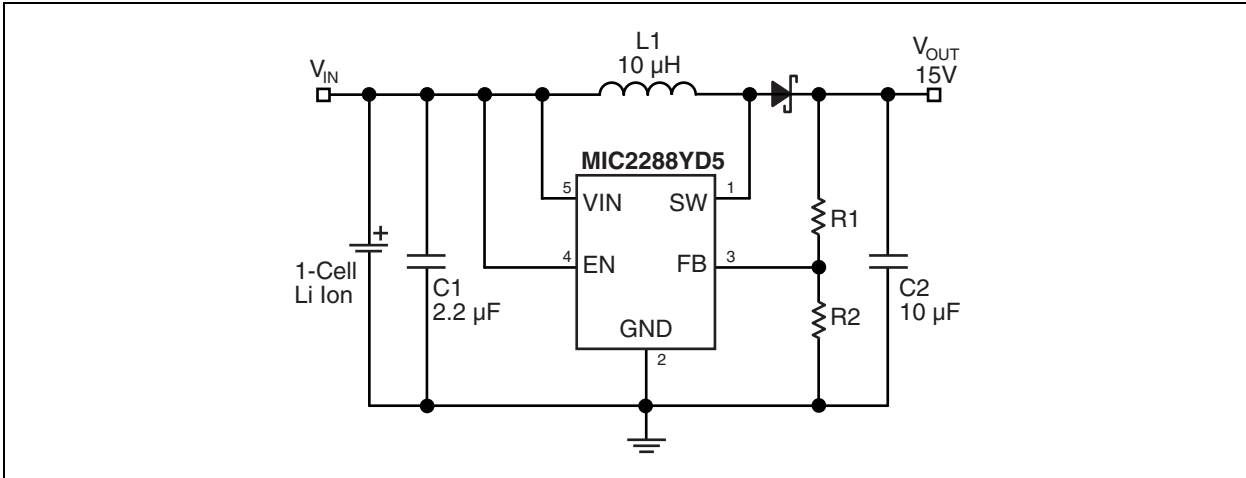

Functional Block Diagram

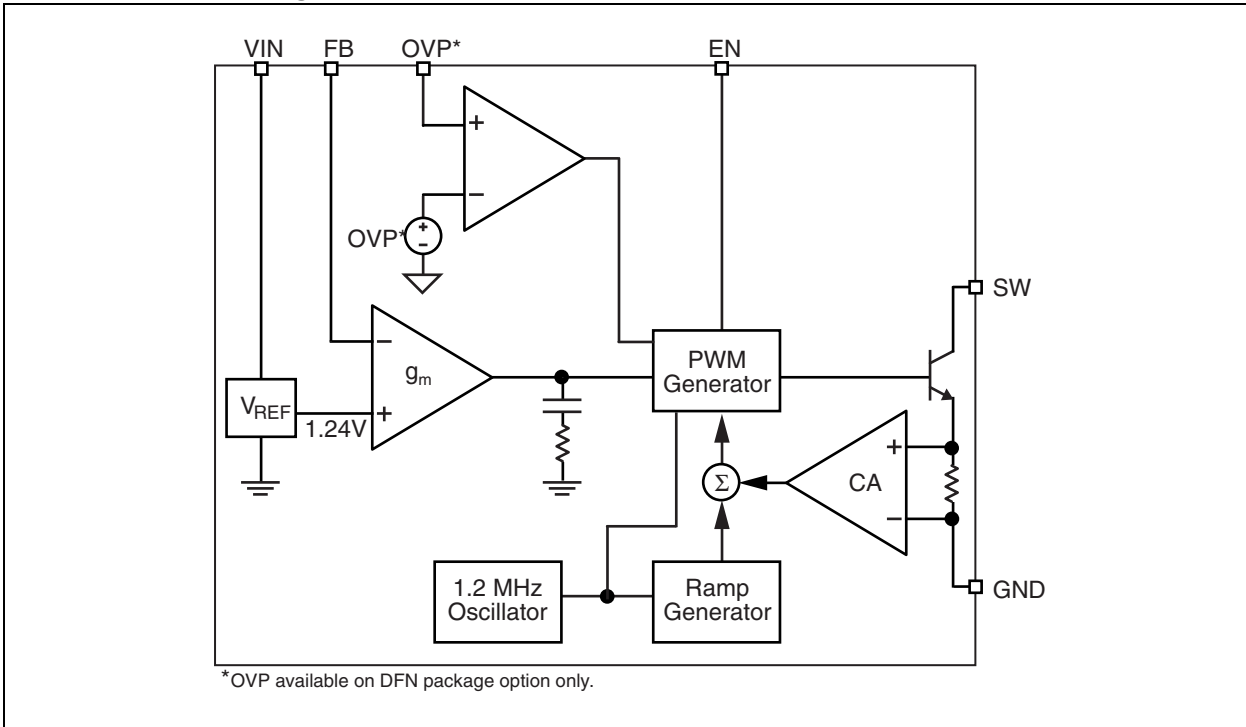

1.0 ELECTRICAL CHARACTERISTICS

Absolute Maximum Ratings†

Supply Voltage (V_{IN})	+12V
Switch Voltage (V_{SW})	-0.3V to +34V
Enable Pin Voltage (V_{EN})	-0.3V to V_{IN}
FB Voltage (V_{FB})	+6.0V
Switch Current (I_{SW})	2A
ESD Rating (Note 1)	+2 kV

Operating Ratings††

Supply Voltage (V_{IN})	+2.5V to +10V
-----------------------------------	---------------

† **Notice:** Stresses above those listed under “Absolute Maximum Ratings” may cause permanent damage to the device. This is a stress rating only and functional operation of the device at those or any other conditions above those indicated in the operational sections of this specification is not intended. Exposure to maximum rating conditions for extended periods may affect device reliability.

†† **Notice:** The device is not ensured to function outside its operating ratings.

Note 1: Devices are ESD-sensitive. Handling precautions are recommended. Human body model, 1.5 k Ω in series with 100 pF.

MIC2288

ELECTRICAL CHARACTERISTICS

Electrical Characteristics: $T_A = +25^\circ\text{C}$, $V_{IN} = V_{EN} = 3.6\text{V}$, $V_{OUT} = 10\text{V}$, $I_{OUT} = 20\text{mA}$, unless otherwise noted. **Bold** values indicate $-40^\circ\text{C} \leq T_J \leq \pm 125^\circ\text{C}$. ⁽¹⁾

Parameter	Sym.	Min.	Typ.	Max.	Units	Conditions
Supply Voltage Range	V_{IN}	2.5	—	10	V	
Undervoltage Lockout	V_{UVLO}	1.8	2.1	2.4	V	
Quiescent Current	I_{VIN}	—	2.8	5	mA	$V_{FB} = 2\text{V}$, not switching
Shutdown Current	I_{SD}	—	0.1	1	μA	$V_{EN} = 0\text{V}$ (Note 2)
Feedback Voltage	V_{FB}	1.227	1.24	1.252	V	$\pm 1\%$
		1.215	—	1.265		$\pm 2\%$, overtemperature
Feedback Input Current	I_{FB}	—	-450	—	nA	$V_{FB} = 1.24\text{V}$
Line Regulation	—	—	0.1	1	%	$3\text{V} \leq V_{IN} \leq 5\text{V}$
Load Regulation	—	—	0.2	—	%	$5\text{mA} \leq I_{OUT} \leq 40\text{mA}$
Maximum Duty Cycle	D_{MAX}	85	90	—	%	
Switch Current Limit	I_{SW}	—	1.2	—	A	
Switch Saturation Voltage	V_{SW}	—	550	—	mV	$I_{SW} = 1\text{A}$
Switch Leakage Current	I_{SW}	—	0.01	5	μA	$V_{EN} = 0\text{V}$, $V_{SW} = 10\text{V}$
Enable Threshold	V_{EN}	1.5	—	—	V	Turn on
		—	—	0.4		Turn off
Enable Pin Current	I_{EN}	—	20	40	μA	$V_{EN} = 10\text{V}$
Oscillator Frequency	f_{SW}	1.05	1.2	1.35	MHz	
Output Overvoltage Protection	V_{OVP}	30	32	34	V	DFN package option only
Overtemperature Threshold Shutdown	T_J	—	150	—	$^\circ\text{C}$	
		—	10	—		Hysteresis

Note 1: Specification for packaged product only.

2: $I_{SD} = I_{VIN}$.

TEMPERATURE SPECIFICATIONS⁽¹⁾

Parameters	Sym.	Min.	Typ.	Max.	Units	Conditions
Temperature Ranges						
Junction Operating Temperature	T_J	-40	—	+125	°C	
Storage Temperature Range	T_S	-65	—	+150	°C	
Package Thermal Resistances						
Thermal Resistance, 2x2 8-Lead DFN	θ_{JA}	—	93	—	°C/W	
Thermal Resistance, 5-Lead TSOT23	θ_{JA}	—	256	—	°C/W	

Note 1: The maximum allowable power dissipation is a function of ambient temperature, the maximum allowable junction temperature and the th1l resistance from junction to air (i.e., T_A , T_J , θ_{JA}). Exceeding the maximum allowable power dissipation will cause the device operating junction temperature to exceed the maximum +125°C rating. Sustained junction temperatures above +125°C can impact the device reliability.

MIC2288

2.0 TYPICAL PERFORMANCE CURVES

Note: The graphs and tables provided following this note are a statistical summary based on a limited number of samples and are provided for informational purposes only. The performance characteristics listed herein are not tested or guaranteed. In some graphs or tables, the data presented may be outside the specified operating range (e.g., outside specified power supply range) and therefore outside the warranted range.

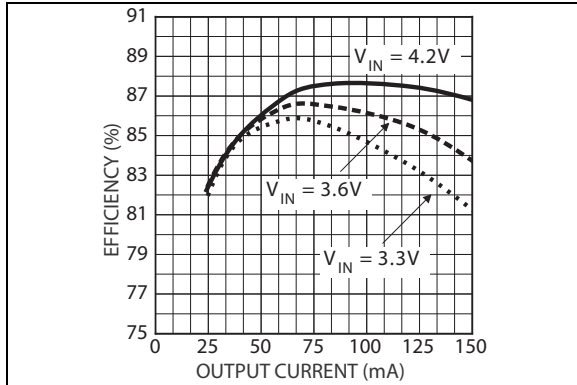

FIGURE 2-1: Efficiency at $V_{OUT} = 12V$.

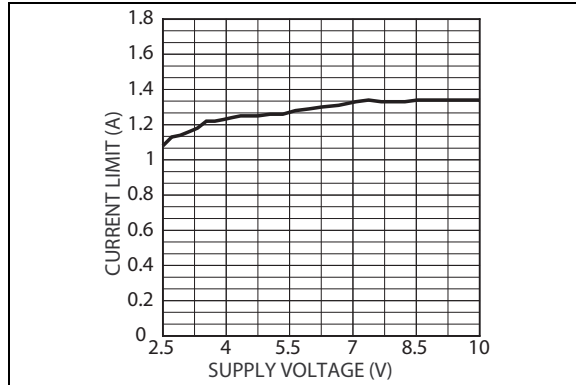

FIGURE 2-4: Current Limit vs. Supply Voltage.

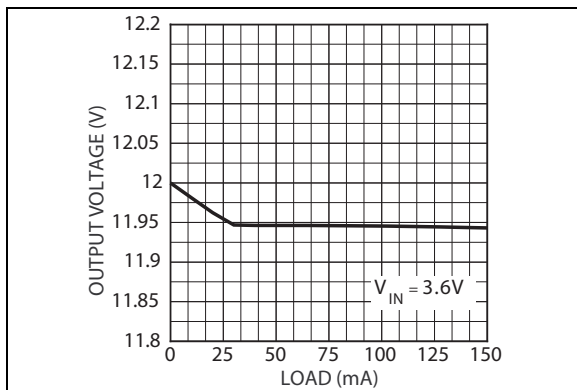

FIGURE 2-2: Load Regulation.

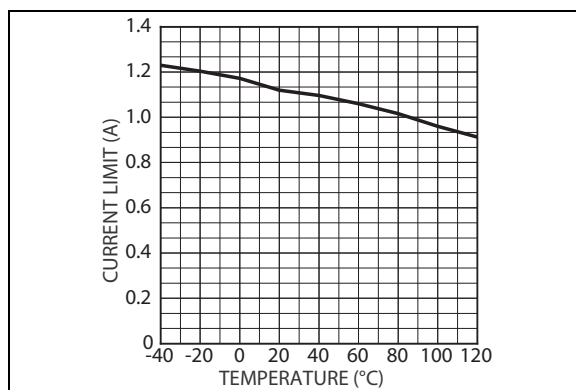

FIGURE 2-5: Current Limit vs. Temperature.

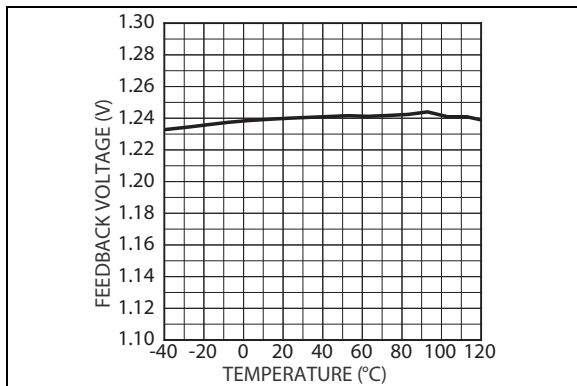

FIGURE 2-3: Feedback Voltage vs. Temperature.

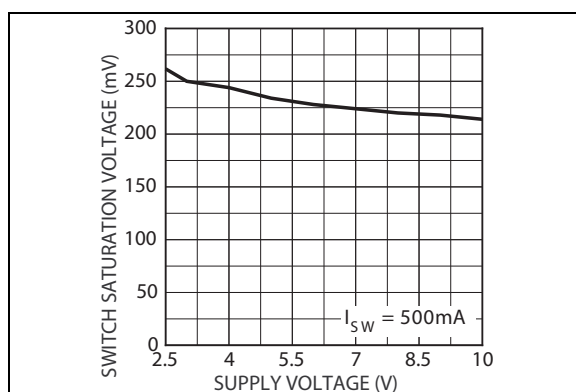

FIGURE 2-6: Switch Saturation vs. Supply Voltage.

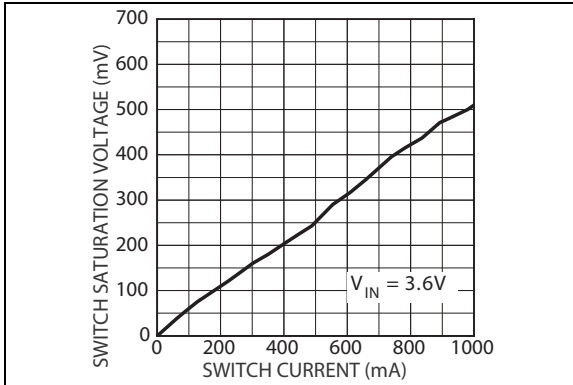

FIGURE 2-7: Switch Saturation vs. Switch Current.

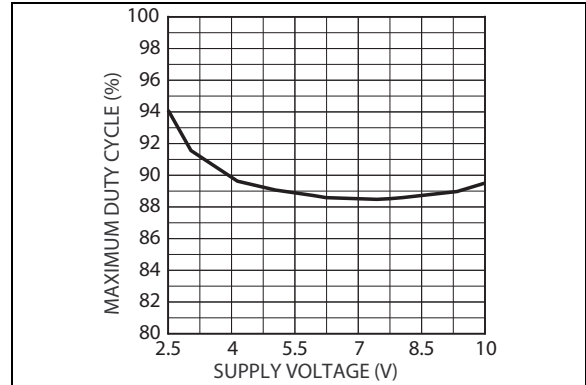

FIGURE 2-10: Maximum Duty Cycle vs. Supply Voltage.

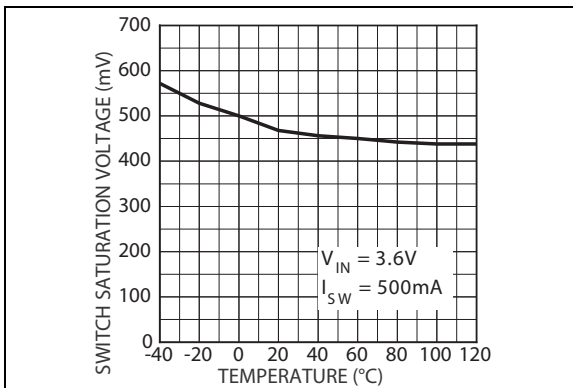

FIGURE 2-8: Switch Saturation vs. Temperature.

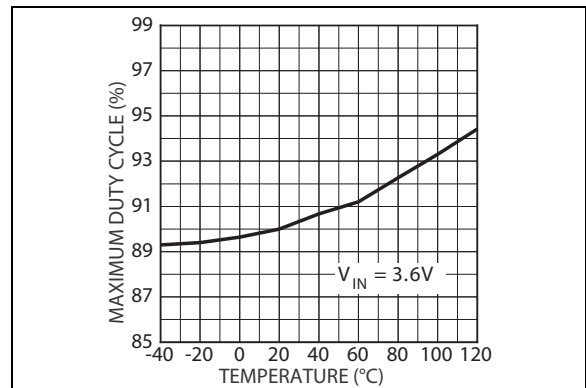

FIGURE 2-11: Maximum Duty Cycle vs. Temperature.

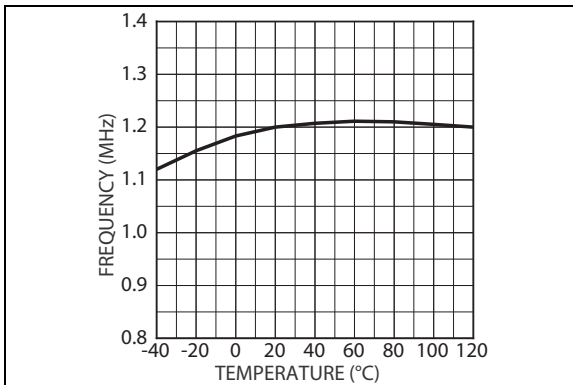

FIGURE 2-9: Frequency vs. Temperature.

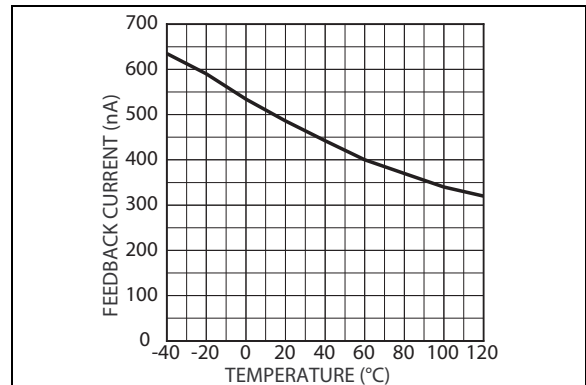

FIGURE 2-12: FB Pin Current vs. Temperature.

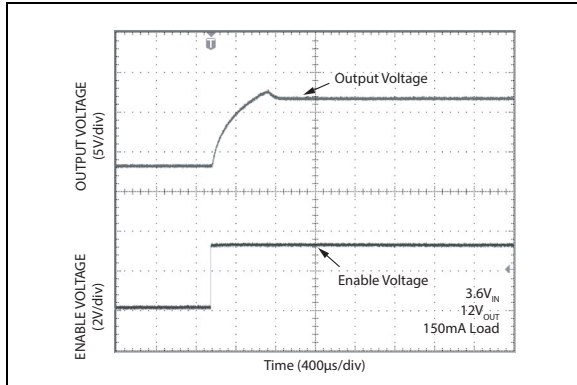

FIGURE 2-13: Enable Characteristics.

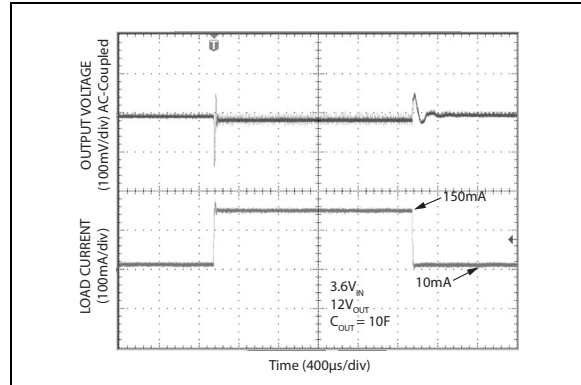

FIGURE 2-15: Load Transient Response.

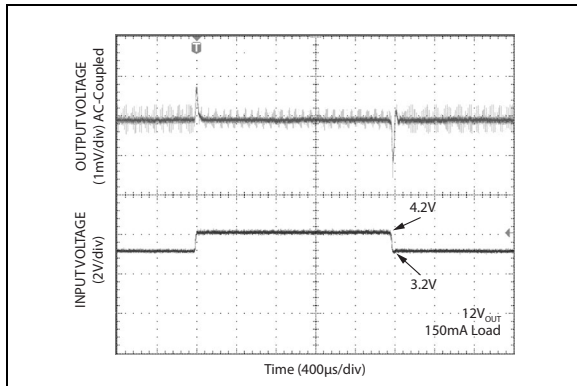

FIGURE 2-14: Line Transient Response.

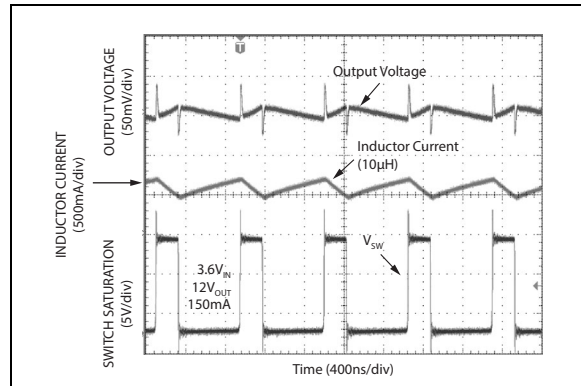

FIGURE 2-16: Output Voltage Ripple and Switching Waveforms.

3.0 PIN DESCRIPTIONS

The descriptions of the pins are listed in [Table 3-1](#).

TABLE 3-1: PIN FUNCTION TABLE

Pin Number 5-Lead TSOT23	Pin Number 8-Lead DFN	Pin Name	Description
1	7	SW	Switch Node (Input): Internal power bipolar collector.
2	—	GND	Ground (Return): Ground.
3	6	FB	Feedback (Input): 1.24V output voltage sense node.
4	3	EN	Enable (Input): Logic high enables regulator. Logic low shuts down regulator. Do not leave floating.
5	2	VIN	Supply (Input): 2.5V to 10V input voltage.
—	1	OVP	Output Overvoltage Protection (Input): Tie this pin to V_{OUT} to clamp the output voltage to 34V maximum in Fault conditions. Tie this pin to ground if OVP function is not required.
—	5	NC	No Connect: No internal connection to die.
—	4	AGND	Analog ground.
—	8	PGND	Power ground.
—	EP	GND	Exposed backside pad.

4.0 FUNCTIONAL DESCRIPTION

The MIC2288 is a constant frequency, PWM Current-mode boost regulator. See the [Functional Block Diagram](#). The MIC2288 is composed of an oscillator, slope compensation ramp generator, current amplifier, g_m error amplifier, PWM generator and a 1A bipolar output transistor. The oscillator generates a 1.2 MHz clock. The clock's two functions are to trigger the PWM generator that turns on the output transistor and to reset the slope compensation ramp generator. The current amplifier is used to measure the switch current by amplifying the voltage signal from the internal sense resistor. The output of the current amplifier is summed with the output of the slope compensation ramp generator. This summed current loop signal is fed to one of the inputs of the PWM generator.

The g_m error amplifier measures the feedback voltage through the external feedback resistors, and amplifies the error between the detected signal and the 1.24V reference voltage. The output of the g_m error amplifier provides the voltage loop signal that is fed to the other input of the PWM generator. When the current loop signal exceeds the voltage loop signal, the PWM generator turns off the bipolar output transistor. The next clock period initiates the next switching cycle, maintaining the constant frequency Current-mode PWM control.

5.0 APPLICATION INFORMATION

5.1 DC/DC PWM Boost Conversion

The MIC2288 is a constant frequency boost converter. It operates by taking a DC input voltage and regulating a higher DC output voltage. Figure 5-1 shows a typical circuit. Boost regulation is achieved by turning on an internal switch, which draws current through the inductor (L1). When the switch turns off, the inductor's magnetic field collapses, causing the current to be discharged into the output capacitor through an external Schottky diode (D1). Voltage regulation is achieved by modulating the pulse width or Pulse-Width Modulation (PWM).

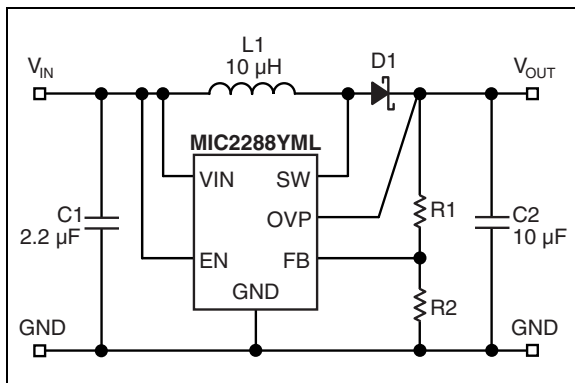

FIGURE 5-1: Typical Application Circuit.

5.2 Duty Cycle Considerations

Duty cycle refers to the switch on-to-off time ratio and can be calculated as follows for a boost regulator:

EQUATION 5-1:

$$D = 1 - \frac{V_{IN}}{V_{OUT}}$$

The duty cycle required for voltage conversion should be less than the maximum duty cycle of 85%. Also, in light load conditions where the input voltage is close to the output voltage, the minimum duty cycle can cause pulse skipping. This is due to the energy stored in the inductor causing the output to overshoot slightly over the regulated output voltage. During the next cycle, the error amplifier detects the output as being high and skips the following pulse. This effect can be reduced by increasing the minimum load or by increasing the inductor value. Increasing the inductor value reduces peak current, which in turn, reduces energy transfer in each cycle.

5.3 Overvoltage Protection

For the DFN package option, there is an overvoltage protection function. If the feedback resistors are disconnected from the circuit, or the feedback pin is shorted to ground, the feedback pin will fall to ground potential. This will cause the MIC2288 to switch at full duty cycle in an attempt to maintain the feedback voltage. As a result, the output voltage will climb out of control. This may cause the switch node voltage to exceed its maximum voltage rating, possibly damaging the IC and the external components. To ensure the highest level of protection, the MIC2288 OVP pin will shut the switch off when an overvoltage condition is detected, saving the regulator and other sensitive circuitry downstream.

5.4 Component Selection

5.4.1 INDUCTOR

Inductor selection is a balance between efficiency, stability, cost, size and rated current. For most applications, 10 µH is the recommended inductor value. It is usually a good balance between these considerations.

Larger inductance values reduce the peak-to-peak ripple current, affecting efficiency. This has the effect of reducing both the DC losses and the transition losses. There is also a secondary effect of an inductor's DC Resistance (DCR). The DCR of an inductor will be higher for more inductance in the same package size. This is due to the longer windings required for an increase in inductance. Because the majority of input current (minus the MIC2288 operating current) is passed through the inductor, higher DCR inductors will reduce efficiency.

To maintain stability, increasing the inductor value will have to be associated with an increase in output capacitance. This is due to the unavoidable "right half plane zero" effect for the continuous current boost converter topology. The frequency at which the right half plane zero occurs can be calculated as follows:

EQUATION 5-2:

$$f_{RHPZ} = \frac{V_{IN}^2}{V_{OUT} \times L \times I_{OUT} \times 2\pi}$$

The right half plane zero has the undesirable effect of increasing gain, while decreasing phase. This requires that the loop gain is rolled off before this has significant effect on the total loop response. This can be accomplished by either reducing inductance (increasing RHPZ frequency) or increasing the output capacitor value (decreasing loop gain).

MIC2288

5.4.2 OUTPUT CAPACITOR

Output capacitor selection is also a trade-off between performance, size and cost. Increasing output capacitance will lead to an improved transient response, but also an increase in size and cost. X5R or X7R dielectric ceramic capacitors are recommended for designs with the MIC2288. Y5V values may be used, but to compensate their drift over temperature, more capacitance is required. The following table shows the recommended ceramic (X5R) output capacitor value vs. output voltage.

TABLE 5-1: OUTPUT CAPACITOR SELECTION

Output Voltage	Recommended Output Capacitance
<6V	22 μ F
<16V	10 μ F
<34V	4.7 μ F

5.4.3 DIODE SELECTION

The MIC2288 requires an external diode for operation. A Schottky diode is recommended for most applications due to their lower forward voltage drop and reverse recovery time. Ensure the diode selected can deliver the peak inductor current and the maximum reverse voltage is rated greater than the output voltage.

5.4.4 INPUT CAPACITOR

A minimum 1 μ F ceramic capacitor is recommended for designing with the MIC2288. Increasing input capacitance will improve performance and greater noise immunity on the source. The input capacitor should be as close as possible to the inductor and the MIC2288, with short traces for good noise performance.

5.4.5 FEEDBACK RESISTORS

The MIC2288 utilizes a feedback pin to compare the output to an internal reference. The output voltage is adjusted by selecting the appropriate feedback resistor network values. The R2 resistor value must be less than or equal to 5 k Ω ($R2 \leq 5 \text{ k}\Omega$). The desired output voltage can be calculated as follows:

EQUATION 5-3:

$$V_{OUT} = V_{REF} \times \left(\frac{R1}{R2} + 1 \right)$$

Where:

$$V_{REF} = 1.24V$$

6.0 APPLICATION CIRCUITS

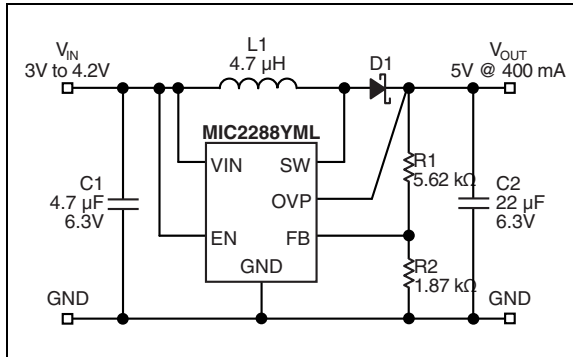

FIGURE 6-1: 3.0V to 4.2V V_{IN} to 5V V_{OUT} @ 400 mA.

Ref	Description	Part Number	Vendor
C1	4.7 μ F, 6.3V, 0805, X5R, Cer Cap	08056D475MAT	AVX
C2	22 μ F, 6.3V, 0805, X5R, Cer Cap	12066D226KAT	AVX
D1	1A, 40V, Schottky Diode	MBRM140T3	On [®] Semi.
L1	4.7 μ H, 650 mA, Inductor	LQH32CN4R7M33L	Murata

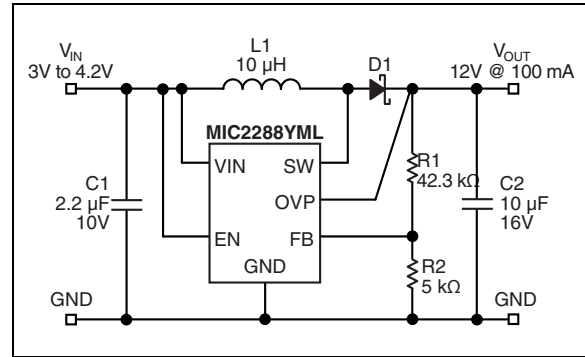

FIGURE 6-3: 3.0V to 4.2V V_{IN} to 12V V_{OUT} @ 100 mA.

Ref	Description	Part Number	Vendor
C1	4.7 μ F, 6.3V, 0805, X5R, Cer Cap	08056D475MAT	AVX
C2	10 μ F, 16V, 1206, X5R, Cer Cap	1206YD106MAT	AVX
D1	1A, 40V, Schottky Diode	MBRM140T3	On [®] Semi.
L1	10 μ H, 650 mA, Inductor	LQH43CN100K03	Murata

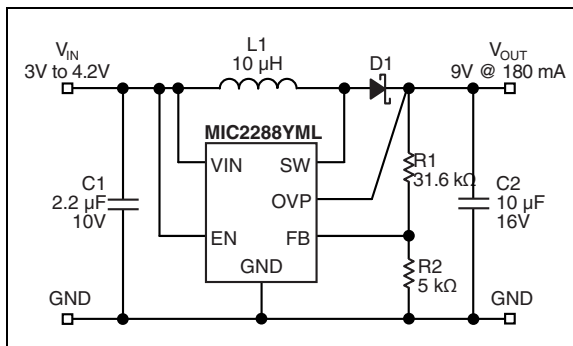

FIGURE 6-2: 3.0V to 4.2V V_{IN} to 9V V_{OUT} @ 180 mA.

Ref	Description	Part Number	Vendor
C1	2.2 μ F, 10V, 0805, X5R, Cer Cap	08052D225KAT	AVX
C2	10 μ F, 16V, 1206, X5R, Cer Cap	1206YD106MAT	AVX
D1	1A, 40V, Schottky Diode	MBRM140T3	On [®] Semi.
L1	10 μ H, 650 mA, Inductor	LQH43CN100K03	Murata

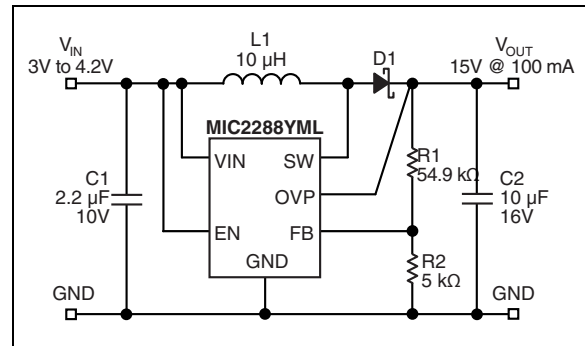

FIGURE 6-4: 3.0V to 4.2V V_{IN} to 15V V_{OUT} @ 100 mA.

Ref	Description	Part Number	Vendor
C1	2.2 μ F, 10V, 0805, X5R, Cer Cap	08052D225KAT	AVX
C2	10 μ F, 16V, 1206, X5R, Cer Cap	1206YD106MAT	AVX
D1	1A, 40V, Schottky Diode	MBRM140T3	On [®] Semi.
L1	10 μ H, 650 mA, Inductor	LQH43CN100K03	Murata

MIC2288

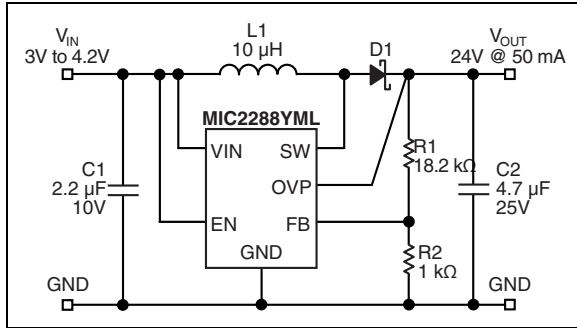

FIGURE 6-5: 3.0V to 4.2V V_{IN} to 24V V_{OUT} @ 50 mA.

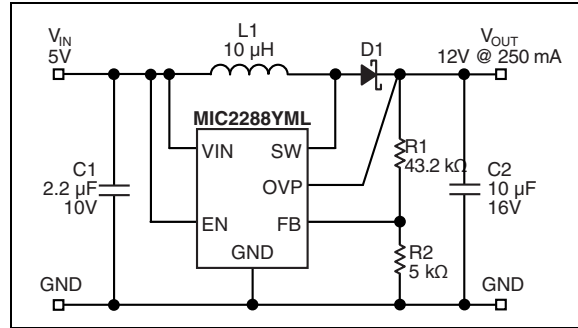

FIGURE 6-7: 5 V_{IN} to 12V V_{OUT} @ 250 mA.

Ref	Description	Part Number	Vendor
C1	2.2 μ F, 10V, 0805, X5R, Cer Cap	08052D225KAT	AVX
C2	4.7 μ F, 25V, 1206, X5R, Cer Cap	12063D475KAT	AVX
D1	1A, 40V, Schottky Diode	MBRM140T3	On [®] Semi.
L1	10 μ H, 650 mA, Inductor	LQH43CN100K03	Murata

Ref	Description	Part Number	Vendor
C1	2.2 μ F, 10V, 0805, X5R, Cer Cap	08052D225KAT	AVX
C2	10 μ F, 16V, 1206, X5R, Cer Cap	1206YD106MAT	AVX
D1	1A, 40V, Schottky Diode	MBRM140T3	On [®] Semi.
L1	10 μ H, 650 mA, Inductor	LQH43CN100K03	Murata

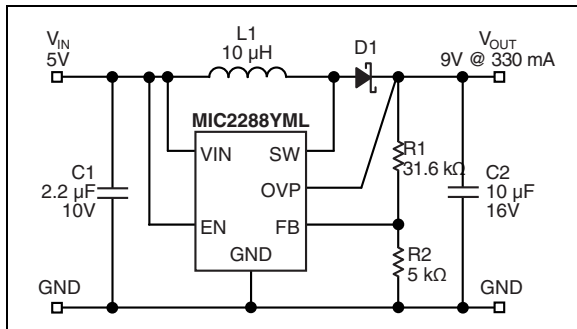

FIGURE 6-6: 5 V_{IN} to 9V V_{OUT} @ 330 mA.

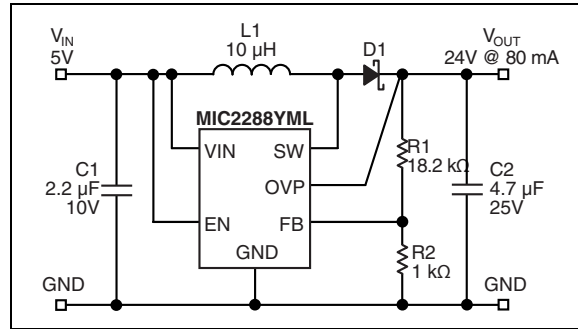

FIGURE 6-8: 5 V_{IN} to 24V V_{OUT} @ 80 mA.

Ref	Description	Part Number	Vendor
C1	2.2 μ F, 10V, 0805, X5R, Cer Cap	08052D225KAT	AVX
C2	10 μ F, 16V, 1206, X5R, Cer Cap	1206YD106MAT	AVX
D1	1A, 40V, Schottky Diode	MBRM140T3	On [®] Semi.
L1	10 μ H, 650 mA, Inductor	LQH43CN100K03	Murata

Ref	Description	Part Number	Vendor
C1	2.2 μ F, 10V, 0805, X5R, Cer Cap	08052D225KAT	AVX
C2	4.7 μ F, 25V, 1206, X5R, Cer Cap	12063D475KAT	AVX
D1	1A, 40V, Schottky Diode	MBRM140T3	On [®] Semi.
L1	10 μ H, 650 mA, Inductor	LQH43CN100K03	Murata

7.0 PACKAGING INFORMATION

7.1 Package Marking Information

5-Lead TSOT23*

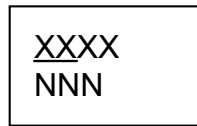

Example

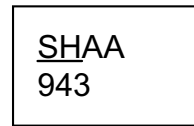

8-Lead TDFN*

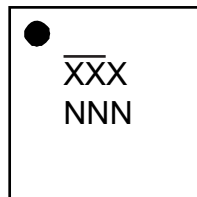

Example

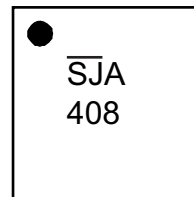

Legend:	XX...X	Product code or customer-specific information
	Y	Year code (last digit of calendar year)
	YY	Year code (last 2 digits of calendar year)
	WW	Week code (week of January 1 is week '01')
	NNN	Alphanumeric traceability code
	(e3)	Pb-free JEDEC® designator for Matte Tin (Sn)
	*	This package is Pb-free. The Pb-free JEDEC designator ((e3)) can be found on the outer packaging for this package.
	•, ▲, ▼	Pin one index is identified by a dot, delta up, or delta down (triangle mark).
Note:	In the event the full Microchip part number cannot be marked on one line, it will be carried over to the next line, thus limiting the number of available characters for customer-specific information. Package may or may not include the corporate logo.	
	Underbar (¯) and/or Overbar (¯) symbol may not be to scale.	

MIC2288

5-Lead Thin SOT23 Package Outline and Recommended Land Pattern

TITLE

5 LEAD TSOT PACKAGE OUTLINE & RECOMMENDED LAND PATTERN

DRAWING #	TSOT-5LD-PL-1	UNIT	MM
------------------	---------------	-------------	----

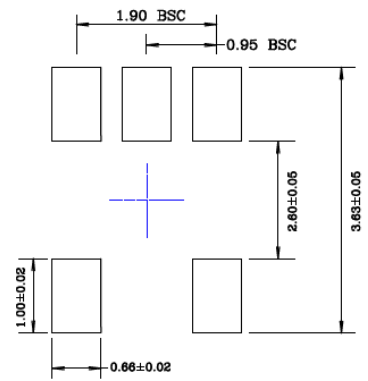
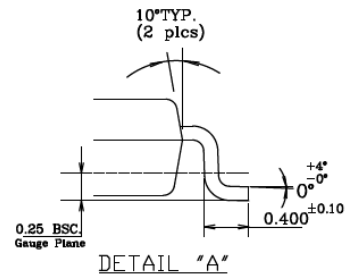
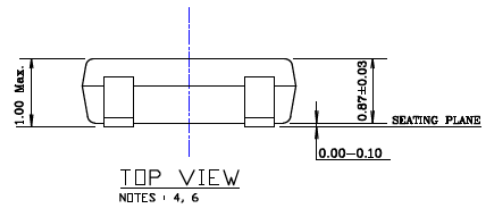
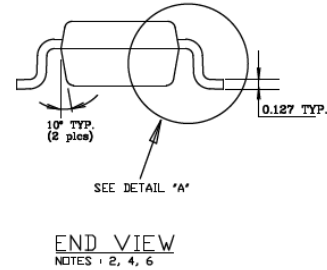
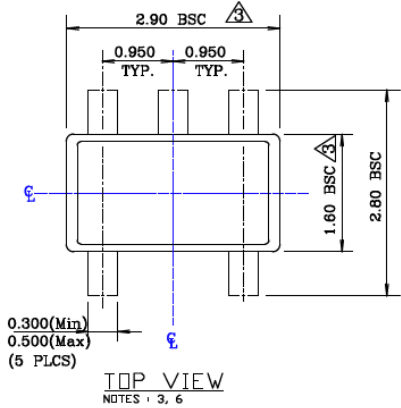

- NOTE:**
1. Dimensions and tolerances are as per ANSI Y14.5M, 1994.
 2. Die is facing up for mold. Die is facing down for trim/form, ie. reverse trim/form.
 3. Dimensions are exclusive of mold flash and gate burr.
 4. The footlength measuring is based on the gauge plane method.
 5. All specification comply to Jedec Spec MO193 Issue C.
 6. All dimensions are in millimeters.

Note: For the most current package drawings, please see the Microchip Packaging Specification located at <http://www.microchip.com/packaging>.

8-Lead 2 mm x 2 mm Thin DFN Package Outline and Recommended Land Pattern

TITLE

8 LEAD TDFN 2x2mm PACKAGE OUTLINE & RECOMMENDED LAND PATTERN

DRAWING #	TDFN22-8LD-PL-1	UNIT	MM
-----------	-----------------	------	----

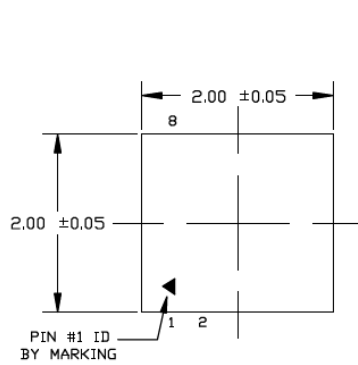

TOP VIEW
NOTE: 1, 2, 3

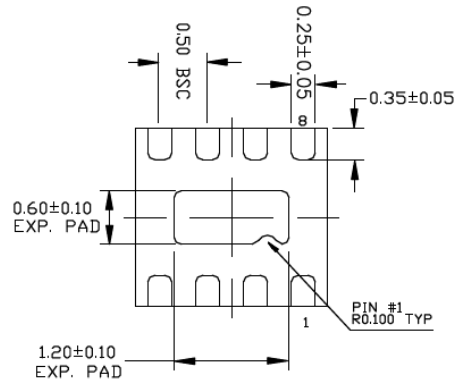

BOTTOM VIEW
NOTE: 1, 2, 3

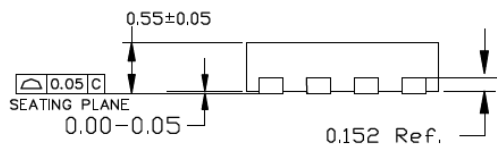

END VIEW
NOTE: 1, 2, 3

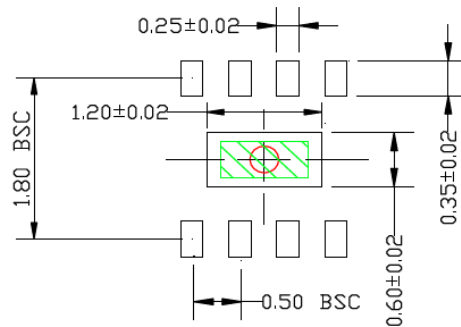

RECOMMENDED LAND PATTERN
NOTE: 4, 5

NOTE:

1. MAX PACKAGE WARPAGE IS 0.05 MM
2. MAX ALLOWABLE BURR IS 0.076MM IN ALL DIRECTIONS
3. PIN #1 IS ON TOP WILL BE LASER MARKED
4. RED CIRCLE IN LAND PATTERN REPRESENTS THERMAL VIA. SIZE SHOULD BE 0.30-0.3 MM IN DIAMETER AND SHOULD BE CONNECTED TO GND FOR MAX THERMAL PERFORMANCE
5. GREEN RECTANGLES (SHADED AREA) REPRESENTS SOLDER STENCIL OPENING ON EXPOSED PAD AREA. SIZE SHOULD BE 0.40x0.90 MM.

Note: For the most current package drawings, please see the Microchip Packaging Specification located at <http://www.microchip.com/packaging>.

MIC2288

NOTES:

APPENDIX A: REVISION HISTORY

Revision C (June 2020)

The following is the list of modifications:

- Updated part numbers C2 and L1 ([Figure 6-1](#)).
- Updated part number L1 ([Figure 6-3](#)).
- Updated part number C2 ([Figure 6-5](#)).
- Updated part numbers C2 and L1 ([Figure 6-8](#)).

Revision B (September 2018)

- Updated values for C2 in the table beneath [Figure 6-3](#).

Revision A (May 2018)

- Converted Micrel document MIC2288 to Microchip data sheet template DS20006034A.
- Minor grammatical text changes throughout.
- Updated Low Output Voltage Ripple in [Features](#).
- Added clarification to EN description in [Table 3-1](#).
- Updated drawing for EN in [Figure 5-1](#).
- Updated drawings and figure captions for each entry in [Section 6.0 “Application Circuits”](#).

MIC2288

NOTES:

PRODUCT IDENTIFICATION SYSTEM

To order or obtain information, e.g., on pricing or delivery, contact your local Microchip representative or sales office.

Device	<u>X</u>	<u>XX</u>	<u>-XX</u>
Part No.	Junction Temp. Range	Package	Media Type
Device:	MIC2288:	1A, 1.2 MHz PWM Boost Converter	
Junction Temperature Range:	Y =	-40°C to +125°C, RoHS-Compliant	
Package:	D5 =	5-Lead Thin SOT23	
	ML =	8-Lead 2 mm x 2 mm TDFN	
Media Type:	TX =	3,000/Reel (Reverse T/R, TSOT only)	
	TR =	3,000/Reel (TSOT only)	
	TR =	5,000/Reel (TDFN only)	

Examples:

a) MIC2288YD5-TX: MIC2288, -40°C to +125°C Temperature Range, 5-Lead TSOT23, 3,000/Reel (Reverse T/R)

b) MIC2288YD5-TR: MIC2288, -40°C to +125°C Temperature Range, 5-Lead TSOT23, 3,000/Reel

c) MIC2288YML-TR: MIC2288, -40°C to +125°C Temperature Range, 8-Lead TDFN, 5,000/Reel

Note 1: Tape and Reel identifier only appears in the catalog part number description. This identifier is used for ordering purposes and is not printed on the device package. Check with your Microchip Sales Office for package availability with the Tape and Reel option.

MIC2288

NOTES:

Note the following details of the code protection feature on Microchip devices:

- Microchip products meet the specification contained in their particular Microchip Data Sheet.
- Microchip believes that its family of products is one of the most secure families of its kind on the market today, when used in the intended manner and under normal conditions.
- There are dishonest and possibly illegal methods used to breach the code protection feature. All of these methods, to our knowledge, require using the Microchip products in a manner outside the operating specifications contained in Microchip's Data Sheets. Most likely, the person doing so is engaged in theft of intellectual property.
- Microchip is willing to work with the customer who is concerned about the integrity of their code.
- Neither Microchip nor any other semiconductor manufacturer can guarantee the security of their code. Code protection does not mean that we are guaranteeing the product as “unbreakable.”

Code protection is constantly evolving. We at Microchip are committed to continuously improving the code protection features of our products. Attempts to break Microchip's code protection feature may be a violation of the Digital Millennium Copyright Act. If such acts allow unauthorized access to your software or other copyrighted work, you may have a right to sue for relief under that Act.

Information contained in this publication regarding device applications and the like is provided only for your convenience and may be superseded by updates. It is your responsibility to ensure that your application meets with your specifications. MICROCHIP MAKES NO REPRESENTATIONS OR WARRANTIES OF ANY KIND WHETHER EXPRESS OR IMPLIED, WRITTEN OR ORAL, STATUTORY OR OTHERWISE, RELATED TO THE INFORMATION, INCLUDING BUT NOT LIMITED TO ITS CONDITION, QUALITY, PERFORMANCE, MERCHANTABILITY OR FITNESS FOR PURPOSE. Microchip disclaims all liability arising from this information and its use. Use of Microchip devices in life support and/or safety applications is entirely at the buyer's risk, and the buyer agrees to defend, indemnify and hold harmless Microchip from any and all damages, claims, suits, or expenses resulting from such use. No licenses are conveyed, implicitly or otherwise, under any Microchip intellectual property rights unless otherwise stated.

Trademarks

The Microchip name and logo, the Microchip logo, Adaptec, AnyRate, AVR, AVR logo, AVR Freaks, BesTime, BitCloud, chipKIT, chipKIT logo, CryptoMemory, CryptoRF, dsPIC, FlashFlex, flexPWR, HELDO, IGLoo, JukeBlox, KeeLoq, Klear, LANCheck, LinkMD, maXStylus, maXTouch, MediaLB, megaAVR, Microsemi, Microsemi logo, MOST, MOST logo, MPLAB, OptoLyzer, PackeTime, PIC, picoPower, PICSTART, PIC32 logo, PolarFire, Prochip Designer, QTouch, SAM-BA, SenGenuity, SpyNIC, SST, SST Logo, SuperFlash, Symmetricom, SyncServer, Tachyon, TempTracker, TimeSource, tinyAVR, UNI/O, Vectron, and XMEGA are registered trademarks of Microchip Technology Incorporated in the U.S.A. and other countries.

APT, ClockWorks, The Embedded Control Solutions Company, EtherSynch, FlashTec, Hyper Speed Control, HyperLight Load, IntelliMOS, Libero, motorBench, mTouch, Powermite 3, Precision Edge, ProASIC, ProASIC Plus, ProASIC Plus logo, Quiet-Wire, SmartFusion, SyncWorld, Temux, TimeCesium, TimeHub, TimePictra, TimeProvider, Vite, WinPath, and ZL are registered trademarks of Microchip Technology Incorporated in the U.S.A.

Adjacent Key Suppression, AKS, Analog-for-the-Digital Age, Any Capacitor, AnyIn, AnyOut, BlueSky, BodyCom, CodeGuard, CryptoAuthentication, CryptoAutomotive, CryptoCompanion, CryptoController, dsPICDEM, dsPICDEM.net, Dynamic Average Matching, DAM, ECAN, EtherGREEN, In-Circuit Serial Programming, ICSP, INICnet, Inter-Chip Connectivity, JitterBlocker, KlearNet, KlearNet logo, memBrain, Mindi, MiWi, MPASM, MPF, MPLAB Certified logo, MPLIB, MPLINK, MultiTRAK, NetDetach, Omniscient Code Generation, PICDEM, PICDEM.net, PICkit, PICtail, PowerSmart, PureSilicon, QMatrix, REAL ICE, Ripple Blocker, SAM-ICE, Serial Quad I/O, SMART-I.S., SQI, SuperSwitcher, SuperSwitcher II, Total Endurance, TSHARC, USBCheck, VariSense, ViewSpan, WiperLock, Wireless DNA, and ZENA are trademarks of Microchip Technology Incorporated in the U.S.A. and other countries.

SQTP is a service mark of Microchip Technology Incorporated in the U.S.A.

The Adaptec logo, Frequency on Demand, Silicon Storage Technology, and Symmcom are registered trademarks of Microchip Technology Inc. in other countries.

GestIC is a registered trademark of Microchip Technology Germany II GmbH & Co. KG, a subsidiary of Microchip Technology Inc., in other countries.

All other trademarks mentioned herein are property of their respective companies.

© 2018-2020, Microchip Technology Incorporated, All Rights Reserved.

ISBN: 978-1-5224-6214-9

For information regarding Microchip's Quality Management Systems, please visit www.microchip.com/quality.



MICROCHIP

Worldwide Sales and Service

AMERICAS

Corporate Office
2355 West Chandler Blvd.
Chandler, AZ 85224-6199
Tel: 480-792-7200
Fax: 480-792-7277
Technical Support:
<http://www.microchip.com/support>
Web Address:
www.microchip.com

Atlanta

Duluth, GA
Tel: 678-957-9614
Fax: 678-957-1455

Austin, TX

Tel: 512-257-3370

Boston

Westborough, MA
Tel: 774-760-0087
Fax: 774-760-0088

Chicago

Itasca, IL
Tel: 630-285-0071
Fax: 630-285-0075

Dallas

Addison, TX
Tel: 972-818-7423
Fax: 972-818-2924

Detroit

Novi, MI
Tel: 248-848-4000

Houston, TX

Tel: 281-894-5983

Indianapolis

Noblesville, IN
Tel: 317-773-8323
Fax: 317-773-5453
Tel: 317-536-2380

Los Angeles

Mission Viejo, CA
Tel: 949-462-9523
Fax: 949-462-9608
Tel: 951-273-7800

Raleigh, NC

Tel: 919-844-7510

New York, NY

Tel: 631-435-6000

San Jose, CA

Tel: 408-735-9110
Tel: 408-436-4270

Canada - Toronto

Tel: 905-695-1980
Fax: 905-695-2078

ASIA/PACIFIC

Australia - Sydney
Tel: 61-2-9868-6733

China - Beijing
Tel: 86-10-8569-7000

China - Chengdu
Tel: 86-28-8665-5511

China - Chongqing
Tel: 86-23-8980-9588

China - Dongguan
Tel: 86-769-8702-9880

China - Guangzhou
Tel: 86-20-8755-8029

China - Hangzhou
Tel: 86-571-8792-8115

China - Hong Kong SAR
Tel: 852-2943-5100

China - Nanjing
Tel: 86-25-8473-2460

China - Qingdao
Tel: 86-532-8502-7355

China - Shanghai
Tel: 86-21-3326-8000

China - Shenyang
Tel: 86-24-2334-2829

China - Shenzhen
Tel: 86-755-8864-2200

China - Suzhou
Tel: 86-186-6233-1526

China - Wuhan
Tel: 86-27-5980-5300

China - Xian
Tel: 86-29-8833-7252

China - Xiamen
Tel: 86-592-2388138

China - Zhuhai
Tel: 86-756-3210040

ASIA/PACIFIC

India - Bangalore
Tel: 91-80-3090-4444

India - New Delhi
Tel: 91-11-4160-8631

India - Pune
Tel: 91-20-4121-0141

Japan - Osaka
Tel: 81-6-6152-7160

Japan - Tokyo
Tel: 81-3-6880-3770

Korea - Daegu
Tel: 82-53-744-4301

Korea - Seoul
Tel: 82-2-554-7200

Malaysia - Kuala Lumpur
Tel: 60-3-7651-7906

Malaysia - Penang
Tel: 60-4-227-8870

Philippines - Manila
Tel: 63-2-634-9065

Singapore
Tel: 65-6334-8870

Taiwan - Hsin Chu
Tel: 886-3-577-8366

Taiwan - Kaohsiung
Tel: 886-7-213-7830

Taiwan - Taipei
Tel: 886-2-2508-8600

Thailand - Bangkok
Tel: 66-2-694-1351

Vietnam - Ho Chi Minh
Tel: 84-28-5448-2100

EUROPE

Austria - Wels
Tel: 43-7242-2244-39
Fax: 43-7242-2244-393

Denmark - Copenhagen
Tel: 45-4485-5910
Fax: 45-4485-2829

Finland - Espoo
Tel: 358-9-4520-820

France - Paris
Tel: 33-1-69-53-63-20
Fax: 33-1-69-30-90-79

Germany - Garching
Tel: 49-8931-9700

Germany - Haan
Tel: 49-2129-3766400

Germany - Heilbronn
Tel: 49-7131-72400

Germany - Karlsruhe
Tel: 49-721-625370

Germany - Munich
Tel: 49-89-627-144-0
Fax: 49-89-627-144-44

Germany - Rosenheim
Tel: 49-8031-354-560

Israel - Ra'anana
Tel: 972-9-744-7705

Italy - Milan
Tel: 39-0331-742611
Fax: 39-0331-466781

Italy - Padova
Tel: 39-049-7625286

Netherlands - Drunen
Tel: 31-416-690399
Fax: 31-416-690340

Norway - Trondheim
Tel: 47-7288-4388

Poland - Warsaw
Tel: 48-22-3325737

Romania - Bucharest
Tel: 40-21-407-87-50

Spain - Madrid
Tel: 34-91-708-08-90
Fax: 34-91-708-08-91

Sweden - Gothenberg
Tel: 46-31-704-60-40

Sweden - Stockholm
Tel: 46-8-5090-4654

UK - Wokingham
Tel: 44-118-921-5800
Fax: 44-118-921-5820