



## SPECIFICATION FOR APPROVAL

### 承 认 书

Description : SMD Buzzer

Vender's Part No. : Cy-SMD-9650-5029

Customer's. Part No. : \_\_\_\_\_

Serial No. : \_\_\_\_\_

Version No. : 1.1.01

CUSTOMER'S APPROVED SIGNATURE		

ChangZhou Chaoyin Electronics Co., Ltd.  
**常州超音电子有限公司**

ADD:中国江苏常州武进庙桥新联工业集中区 58 号

TEL: +86-0519-88298758

FAX: +86-0519-86464158

Http: //www.smdbuzzer.net

Approved By	Checked By	Made By
<b>ShenWuMing</b>	<b>ZhangWei</b>	<b>LiLin</b>
<b>2007-02-16</b>	<b>2007-02-16</b>	<b>2007-02-16</b>

## A. SCOPE

This specification applies magnetic buzzer, **Cy-SMD-9650-5029**

## B. SPECIFICATION

No.	Item	Unit	Specification	Condition
1	Oscilation Frequency	KHz	2.9±0.2	
2	Operating Voltage	V <sub>DC</sub>	2~7	
3	Rated Voltage	V <sub>DC</sub>	5.0	
4	Current Consumption	mA	MAX.30	at Rated Voltage
5	Sound Pressure Level	dB	MIN.80	at 10cm at Rated Voltage
6	Tone/Pulse Rated		Single	
7	Operating Temperature	°C	-20~+70	
8	Storage Temperature	°C	-30~+80	
9	Dimension	mm	9.6×9.6×H5.5	See appearance drawing
10	Weight(MAX)	gram	1.5	
11	Housing Material		PPS(Black)	
12	Leading Pin		Plated Brass(Au)	See appearance drawing
13	Environmental Protection Regulation		RoHS	

## C. APPEARANCE DRAWING

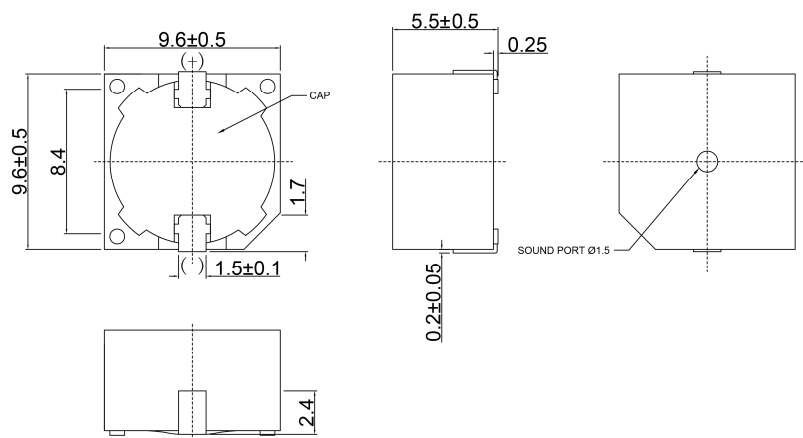

Tol:±0.3 Unit:mm

## D. TESTING METHOD

### Standard Measurement Conditions:

Temperature:  $25 \pm 2^\circ\text{C}$  Humidity: 45-65%

### Acoustic Characteristics:

The oscillation frequency, current consumption and sound pressure are measured by the measuring instruments shown below

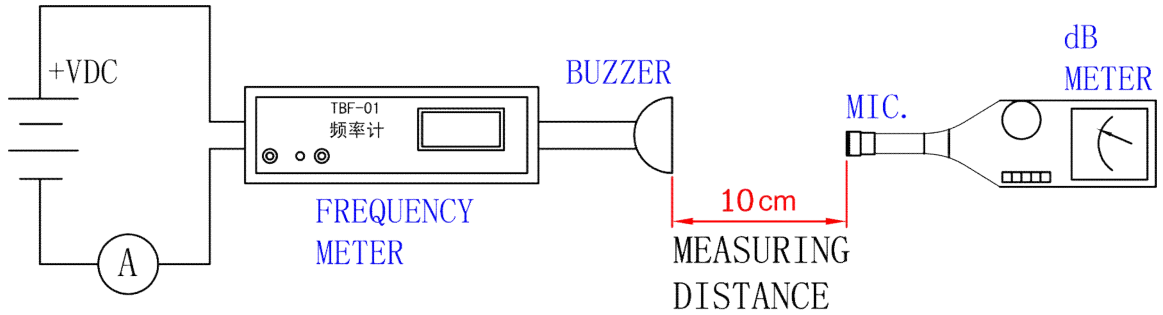

In the measuring test, buzzer is placed as follows:

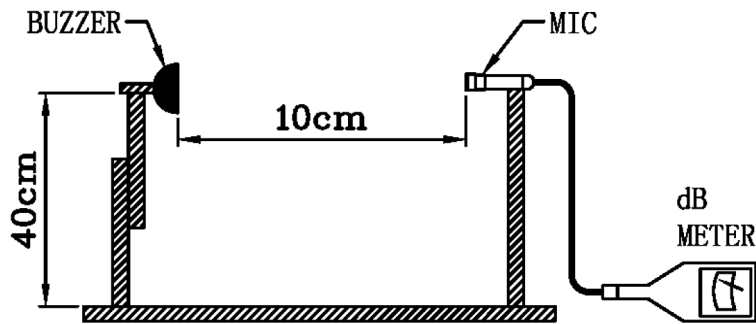

## E. Typical Frequency Response Curve

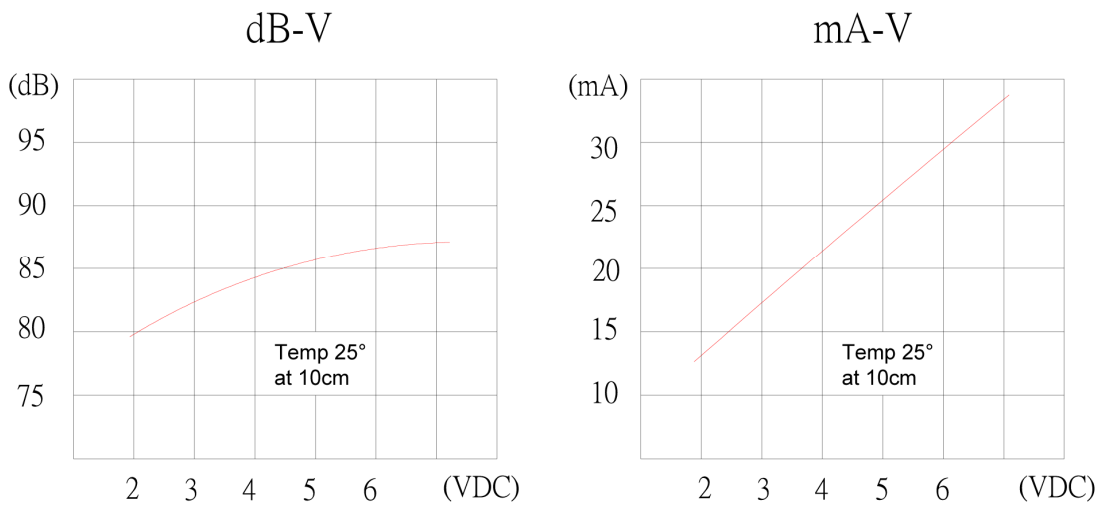

## F. Soldering Condition

(1) Recommendable reflow soldering condition is as follows (Reflow soldering is twice)

Note: It is requested that reflow soldering should be executed after heat of product goes down to normal.

TEMPERATURE

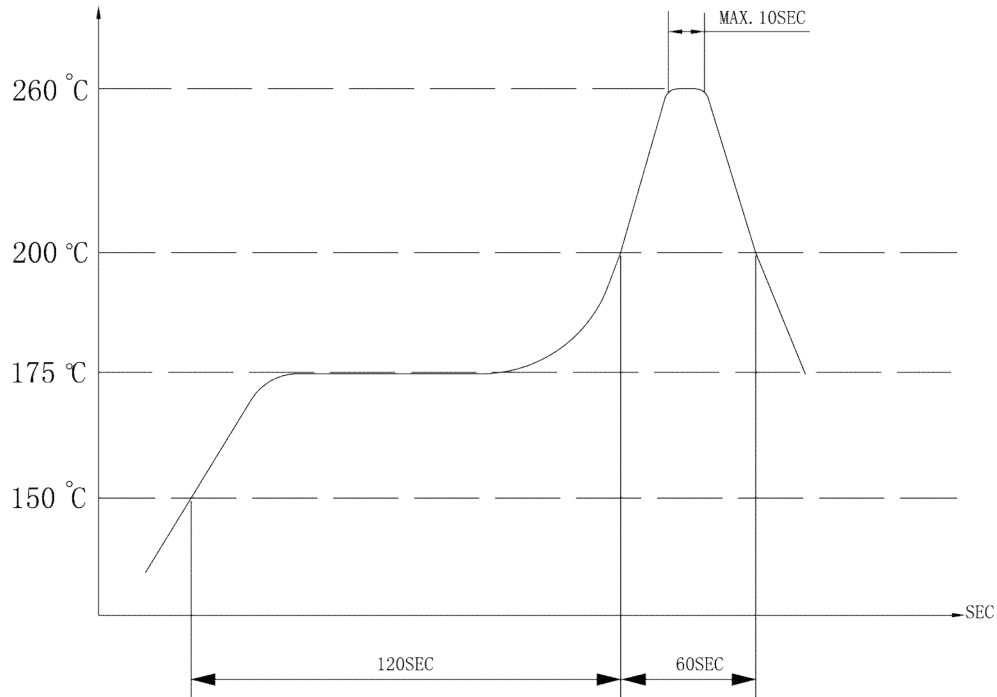

Heat resistant line

(Used when heat resistant reliability test is performed)

(2) Manual soldering

Manual soldering temperature 350 °C within 5 sec.

## G. RELIABILITY TEST

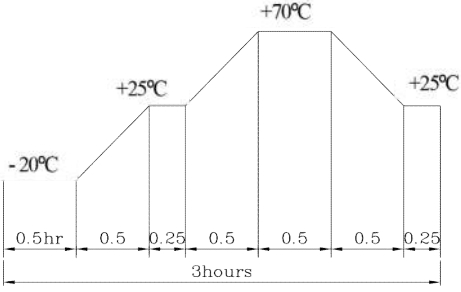
NO.	ITEM	TEST CONDITION AND REQUIREMENT
1	High Temperature Test (Storage)	After being placed in a chamber with $85\pm 2^{\circ}\text{C}$ for 96 hours and then being placed in normal condition for 2 hours. Allowable variation of SPL after test: $\pm 10\text{dB}$ .
2	Low Temperature Test (Storage)	After being Placed in a chamber with $-30\pm 2^{\circ}\text{C}$ for 96 hours and then being placed in normal condition for 2 hours. Allowable variation of SPL after test: $\pm 10\text{dB}$ .
3	Humidity Test	After being Placed in a chamber with 90-95% R.H. at $40\pm 2^{\circ}\text{C}$ for 96 hours and then being placed in normal condition for 2 hours. Allowable variation of SPL after test: $\pm 10\text{dB}$ .
4	Temperature Cycle Test	<p>The part shall be subjected to 5 cycles. One cycle shall be consist of:</p>  <p>The part shall be subjected to 5 cycles. One cycle shall be consist of:</p>
5	Drop Test	Drop on a hard wood board of 4cm thick, any directions ,6 times, at the height of 75cm . Allowable variation of SPL after test: $\pm 10\text{dB}$ .
6	Vibration Test	After being applied vibration of amplitude of 1.5mm with 10 to 55 Hz band of vibration frequency to each of 3 perpendicular directions for 2 hours . Allowable variation of SPL after test: $\pm 10\text{dB}$ .
7	Solderability Test	Lead terminals are immersed in rosin for 5 seconds and then immersed in solder bath of $+300\pm 5^{\circ}\text{C}$ for $3\pm 1$ seconds . 90% min. lead terminals shall be wet with solder (Except the edge of terminals).
8	Terminal Strength Pulling Test	The force of 9.8N(1.0kg) is applied to each terminal in axial direction for 10 seconds. No visible damage and cutting off.

### TEST CONDITION.

Standard Test Condition : a) Temperature :  $+5 \sim +35^{\circ}\text{C}$  b) Humidity : 45-85% c) Pressure : 860-1060mbar

一般测试条件 : a) 温度 :  $+5 \sim +35^{\circ}\text{C}$  b) 湿度 : 45-85% c) 气压 : 860-1060mbar

Judgment Test Condition : a) Temperature :  $+25\pm 2^{\circ}\text{C}$  b) Humidity : 60-70% c) Pressure : 860-1060mbar

争议时测试条件 : a) 温度 :  $+25 \pm 2^{\circ}\text{C}$  b) 湿度 : 60-70% c) 气压 : 860-1060mbar

# I. PACKING STANDARD

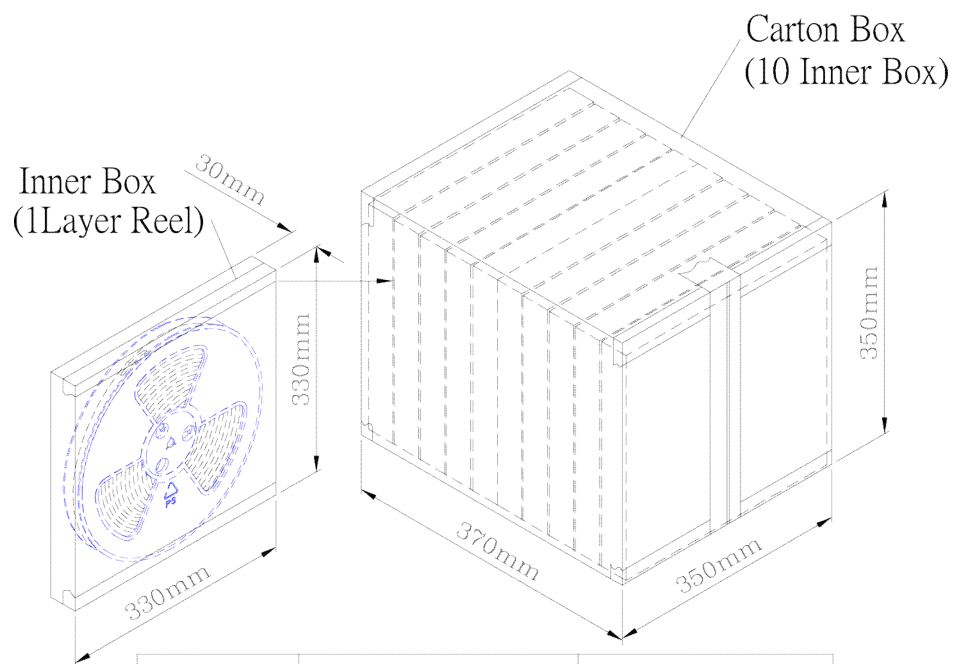
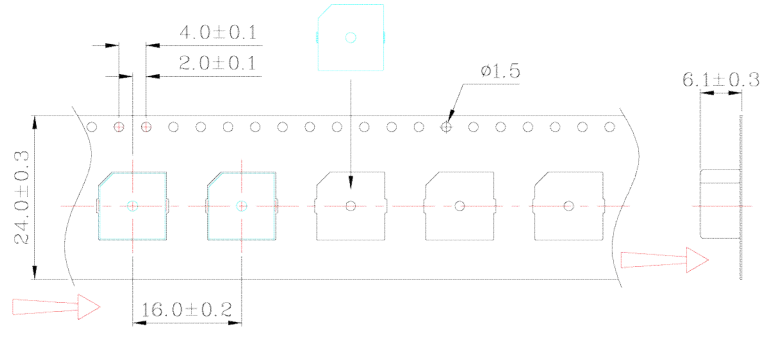
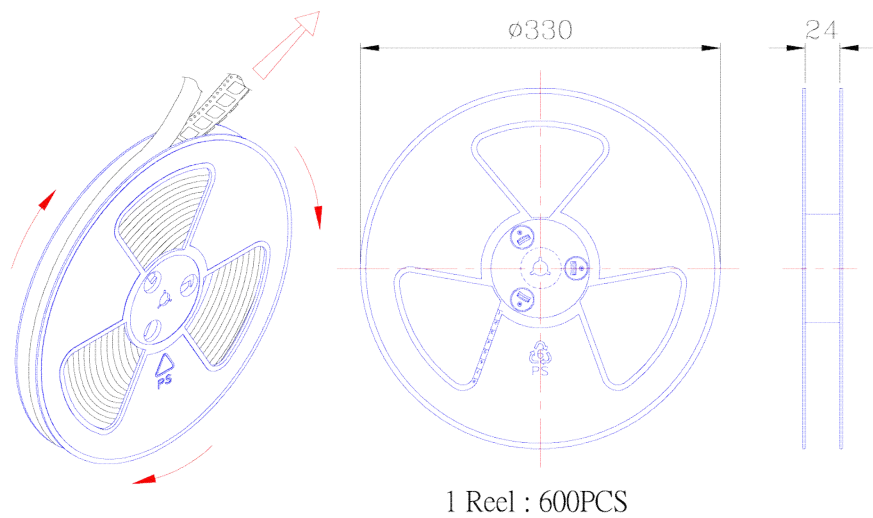

Inner Box	330mmx330mmx30mm	1x600PCS=600PCS
Carton Box	350mmx350mmx370mm	10x600PCS=6,000PCS