

# SPECIFICATION FOR APPROVAL

## 产品规格承认书

HONGLI P/N 产品型号  
HLXS-386B2WL6S

<input type="checkbox"/> R&D <input checked="" type="checkbox"/> Mass Product 量产供货		
Supplier 供应商		
Approved By 核准	Checked By 初审	Prepared By 编制
郭勇	孙培森	侯昌信

## Contents 目录

1. Description 产品介绍.....	3
1.1 General Description 产品描述.....	3
1.2 Part number code description 型号代码描述.....	3
1.3 Features 产品特征.....	4
1.4 Application 产品应用.....	4
1.5 Package Dimension 封装尺寸.....	5
1.6 Product Parameters 产品参数.....	6
1.7 Product Binning 产品分 BIN.....	7
1.8 Typical Optical Characteristics Curves 典型光学特性曲线.....	11
2. Packaging 产品包装.....	15
2.1 Packaging Specification 包装规格.....	15
2.1.1 Carrier Tape Dimension 载带尺寸.....	15
2.1.2 Reel Dimension 卷盘尺寸.....	15
2.2 Moisture Resistant Packing 防潮包装.....	15
2.3 Reliability Test Items And Conditions 信赖性测试项目及条件.....	17
2.4 Criteria For Judging Damage 失效判定标准.....	18
3. SMT Reflow Soldering Instructions SMT 回流焊说明.....	19
3.1 SMT Reflow Soldering Instructions SMT 回流焊说明.....	19
4. Handling Precautions 产品使用注意事项.....	20
4.1 Handling Precautions 产品使用注意事项.....	20

## 1. Description 产品介绍

### 1.1 General Description 产品描述

The White LED, which is formed by blue chip exciting phosphor.

Product Package: 3.8mmX1.0mmX0.6mm.

该产品为白光LED，是由蓝光芯片激发荧光粉而形成，产品尺寸：3.8mmX1.0mmX0.6mm。



### 1.2 Part number code description 型号代码描述

X<sub>1</sub>X<sub>2</sub>X<sub>3</sub>X<sub>4</sub>-X<sub>5</sub>X<sub>6</sub>X<sub>7</sub>X<sub>8</sub>X<sub>9</sub>X<sub>10</sub>X<sub>11</sub>X<sub>12</sub>X<sub>13</sub>

Part number code (型号代码)	Description (说明)	Part number (型号)	Value (属性)
X <sub>1</sub> ~X <sub>4</sub>	Company (公司)	HLXS	鸿利显示
X <sub>5</sub> ~X <sub>7</sub>	Product Size (产品尺寸)	386	3806系列
X <sub>8</sub>	Voltage classification and characteristics (电压分类与特性)	B	单晶低压2.7-2.9V
X <sub>9</sub>	Drive current (驱动电流)	2	20mA
X <sub>10</sub> X <sub>11</sub>	Emitting Color (发光颜色)	WL	白光
X <sub>12</sub>	Color Gamut (色域范围)	6	常规色域65%-72%
X <sub>13</sub>	Patent (专利)	S	非专利

### 1.3 Features 产品特征

- ▶ Side view white LED 侧发光白光 LED
- ▶ White SMT Package 白色 SMT 包装
- ▶ Lead frame package with individual 2 pins 由两个引脚组成的引线加框组件
- ▶ Suitable for all SMT assembly and solder process.适用于所有的 SMT 组装和焊接工艺
- ▶ Extremely wide viewing angle 发光角度
- ▶ Available on tape and reel.适用于载带及卷轴
- ▶ RoHS compliant.满足 RoHS 要求

### 1.4 Application 产品应用

- ▶ Mobile Phones 手机
- ▶ Notebook 笔记本
- ▶ Industrial display 工业显示
- ▶ Backlight for LCD, switch and symbol, display.LCD 背光、转换器, 开关和标志, 显示器等
- ▶ General use.其他应用

## 1.5 Package Dimension 封装尺寸

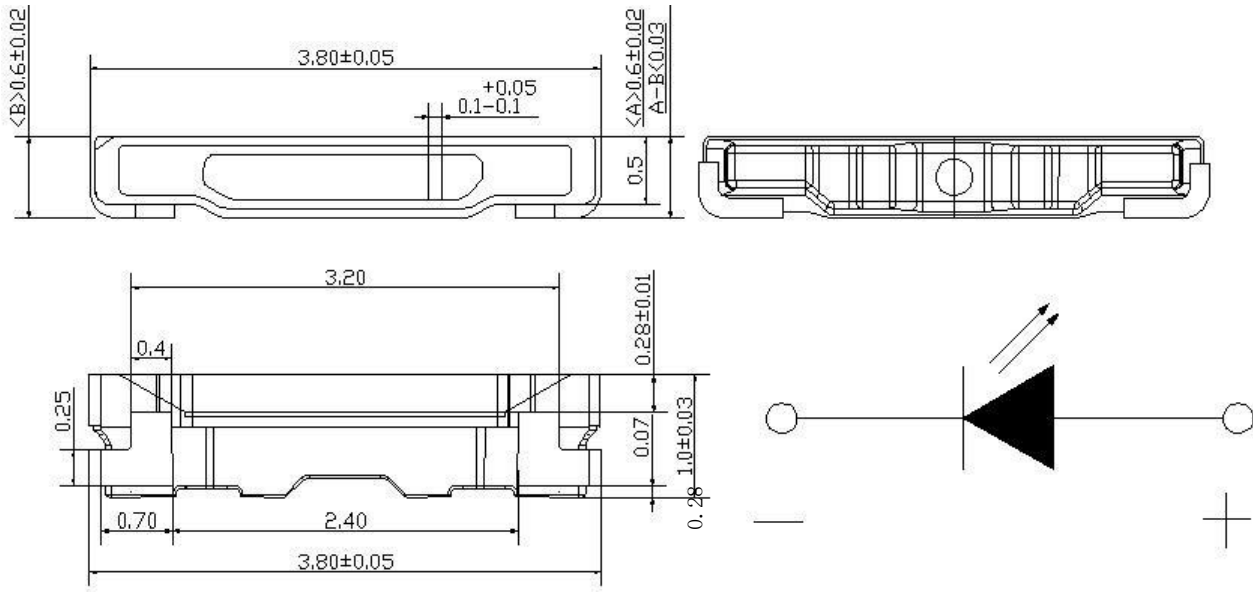

Fig. 1-1 Package Dimension 封装尺寸

### Note 备注:

1. All dimensions tolerances are  $\pm 0.2$  mm unless otherwise noted. 除特别标注外, 所有尺寸公差为  $\pm 0.1$  毫米
2. All are in units of mm. 所有尺寸标注单位为毫米

## 1.6 Product Parameters 产品参数

Table 1-1 Electrical / Optical Characteristics at Ts=25°C 电性与光学特性

Parameter (参数)	Symbol (符号)	Min. (最小值)	Typ. (典型值)	Max. (最大值)	Unit (单位)	Condition (条件)
Luminous Intensity (光通量)	IV	---	3100	---	mcd	IF=20mA
Viewing Angle (发光角度)	2θ1/2	---	120	---	deg	IF=20mA
Forward Voltage (正向电压)	VF	---	2.85	---	V	IF=20mA
Reverse Current (反向电流)	IR	---	0.05	---	μA	VR=7V

Table 1-2 Absolute Maximum Ratings at Ts=25°C 绝对最大值

Parameter (参数)	Symbol (符号)	Rating (值)	Unit (单位)
Reverse Voltage (反向电压)	VR	7	V
Forward Current (正向电流)	IF	30	mA
Pulse Forward Current (Duty 1/10 @1KHz) (脉冲电流)	IFP	100	mA
Electrostatic Discharge(HBM)*1 (静电)	ESD	2000	V
LED Junction Temperature (结温)	Tj	105	°C
Operating Temperature (操作温度)	Topr	-30 ~ +85	°C
Storage Temperature (储存温度)	Tstg	-40 ~ +100	°C
Soldering Temperature (焊接温度)	Tsol	Reflow Soldering: 260°C for 10sec.	

## 1.7 Product Binning 产品分 BIN

Table 1-3 Forward Voltage 电压:( Tolerance:  $\pm 0.03V$ @ IF= 20mA @ Ta=25°C)

BIN CODE	Min.	Max.	Unit	Condition
V27	2.7	2.8	V	IF=20mA
V28	2.8	2.9		

Table 1-4 Luminous Intensity 流明: ( Tolerance:  $\pm 3\%$  @ IF = 20mA @ Ta=25°C)

BIN CODE	IF=20mA Test			
	Min(mcd)	Max(mcd)	Min(lm)	Max(lm)
28	2150	2250	6.00	6.25
29	2250	2350	6.25	6.50
30	2350	2450	6.50	6.75
31	2450	2550	6.75	7.00
32	2550	2650	7.00	7.25
33	2650	2750	7.25	7.50
34	2750	2850	7.50	7.75
35	2850	2950	7.75	8.00
36	2950	3050	8.00	8.25
37	3050	3150	8.25	8.50
38	3150	3250	8.50	8.75
39	3250	3350	8.75	9.00
40	3350	3450	9.00	9.25
41	3450	3550	9.25	9.50
42	3550	3650	9.50	9.75
43	3650	3750	9.75	10.00
44	3750	3850	10.00	10.25
45	3850	3950	10.25	10.50
46	3950	4050	10.50	10.75
47	4050	4150	10.75	11.00
48	4150	4250	11.00	11.25
49	4250	4350	11.25	11.50

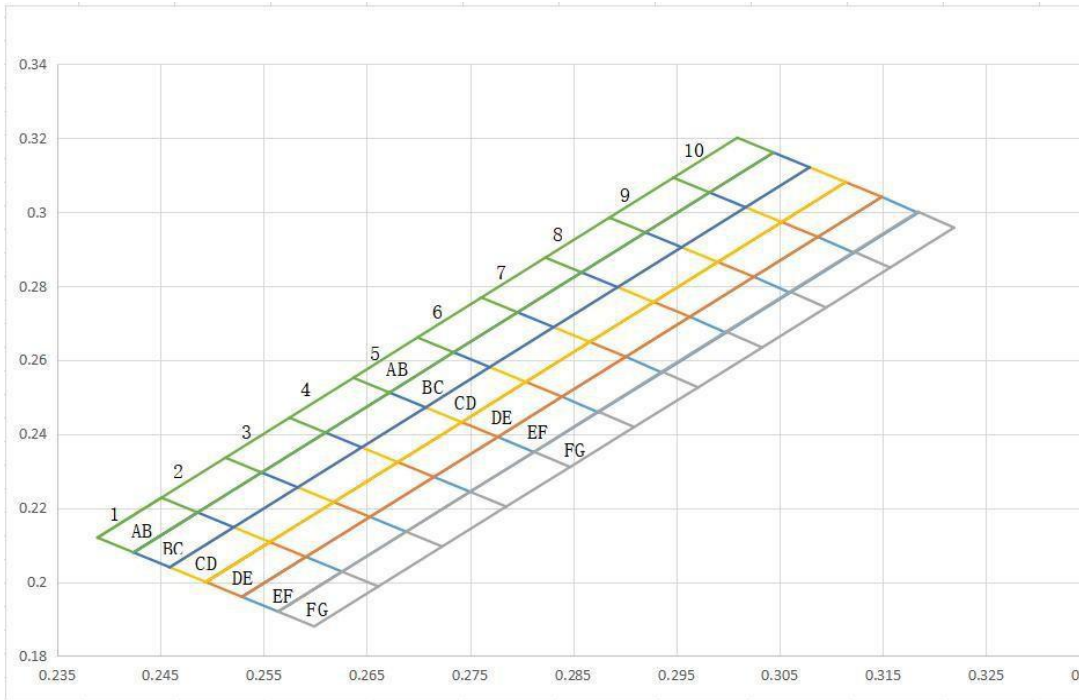

Fig. 1-2 The C.I.E Chromaticity Diagram CIE色度图

Table 1-5

AB1	0.2389	0.212	BC1	0.2424	0.208	CD1	0.2459	0.204
	0.2451	0.2228		0.2486	0.2188		0.2521	0.2148
	0.2486	0.2188		0.2521	0.2148		0.2556	0.2108
	0.2424	0.208		0.2459	0.204		0.2494	0.2
AB2	0.2451	0.2228	BC2	0.2486	0.2188	CD2	0.2521	0.2148
	0.2513	0.2336		0.2548	0.2296		0.2583	0.2256
	0.2548	0.2296		0.2583	0.2256		0.2618	0.2216
	0.2486	0.2188		0.2521	0.2148		0.2556	0.2108
AB3	0.2513	0.2336	BC3	0.2548	0.2296	CD3	0.2583	0.2256
	0.2575	0.2444		0.261	0.2404		0.2645	0.2364
	0.261	0.2404		0.2645	0.2364		0.268	0.2324
	0.2548	0.2296		0.2583	0.2256		0.2618	0.2216
AB4	0.2575	0.2444	BC4	0.261	0.2404	CD4	0.2645	0.2364
	0.2637	0.2552		0.2672	0.2512		0.2707	0.2472
	0.2672	0.2512		0.2707	0.2472		0.2742	0.2432
	0.261	0.2404		0.2645	0.2364		0.268	0.2324
AB5	0.2637	0.2552	BC5	0.2672	0.2512	CD5	0.2707	0.2472
	0.2699	0.2661		0.2734	0.2621		0.2769	0.2581
	0.2734	0.2621		0.2769	0.2581		0.2804	0.2541
	0.2672	0.2512		0.2707	0.2472		0.2742	0.2432



AB6	0.2699	0.2661	BC6	0.2734	0.2621	CD6	0.2769	0.2581
	0.2761	0.2769		0.2796	0.2729		0.2831	0.2689
	0.2796	0.2729		0.2831	0.2689		0.2769	0.2649
	0.2734	0.2621		0.2769	0.2581		0.2804	0.2541
AB7	0.2761	0.2769	BC7	0.2796	0.2729	CD7	0.2831	0.2689
	0.2823	0.2877		0.2858	0.2837		0.2893	0.2797
	0.2858	0.2837		0.2893	0.2797		0.2928	0.2757
	0.2796	0.2729		0.2831	0.2689		0.2866	0.2649
AB8	0.2823	0.2877	BC8	0.2858	0.2837	CD8	0.2893	0.2797
	0.2885	0.2985		0.292	0.2945		0.2955	0.2905
	0.292	0.2945		0.2955	0.2905		0.299	0.2865
	0.2858	0.2837		0.2893	0.2797		0.2928	0.2757
AB9	0.2885	0.2985	BC9	0.292	0.2945	CD9	0.2955	0.2905
	0.2947	0.3093		0.2982	0.3053		0.3017	0.3013
	0.2982	0.3053		0.3017	0.3013		0.3052	0.2973
	0.292	0.2945		0.2955	0.2905		0.299	0.2865
AB10	0.2947	0.3093	BC10	0.2982	0.3053	CD10	0.3017	0.3013
	0.3009	0.3201		0.3044	0.3161		0.3079	0.3121
	0.3044	0.3161		0.3079	0.3121		0.3114	0.3081
	0.2982	0.3053		0.3017	0.3013		0.3052	0.2973
DE1	0.2494	0.2	EF1	0.2529	0.196	FG1	0.2564	0.192
	0.2556	0.2108		0.2591	0.2068		0.2626	0.2028
	0.2591	0.2068		0.2626	0.2028		0.2661	0.1988
	0.2529	0.196		0.2564	0.192		0.2599	0.188
DE2	0.2556	0.2108	EF2	0.2591	0.2068	FG2	0.2626	0.2028
	0.2618	0.2216		0.2653	0.2176		0.2688	0.2136
	0.2653	0.2176		0.2688	0.2136		0.2723	0.2096
	0.2591	0.2068		0.2626	0.2028		0.2661	0.1988
DE3	0.2618	0.2216	EF3	0.2653	0.2176	FG3	0.2688	0.2136
	0.268	0.2324		0.2715	0.2284		0.275	0.2244
	0.2715	0.2284		0.275	0.2244		0.2785	0.2204
	0.2653	0.2176		0.2688	0.2136		0.2723	0.2096
DE4	0.268	0.2324	EF4	0.2715	0.2284	FG4	0.275	0.2244
	0.2742	0.2432		0.2777	0.2392		0.2812	0.2352
	0.2777	0.2392		0.2812	0.2351		0.2847	0.2311
	0.2715	0.2284		0.275	0.2244		0.2785	0.2204
DE5	0.2742	0.2432	EF5	0.2777	0.2392	FG5	0.2812	0.2352
	0.2804	0.2541		0.2839	0.2501		0.2874	0.2461
	0.2839	0.2501		0.2874	0.2459		0.2909	0.2419
	0.2777	0.2392		0.2812	0.2351		0.2847	0.2311
DE6	0.2804	0.2541	EF6	0.2839	0.2501	FG6	0.2874	0.2461
	0.2866	0.2649		0.2901	0.2609		0.2936	0.2569
	0.2901	0.2609		0.2936	0.2566		0.2971	0.2526
	0.2839	0.2501		0.2874	0.2459		0.2909	0.2419

DE7	0.2866	0.2649	EF7	0.2901	0.2609	FG7	0.2936	0.2569
	0.2928	0.2757		0.2963	0.2717		0.2998	0.2677
	0.2963	0.2717		0.2998	0.2674		0.3033	0.2634
	0.2901	0.2609		0.2936	0.2566		0.2971	0.2526
DE8	0.2928	0.2757	EF8	0.2963	0.2717	FG8	0.2998	0.2677
	0.299	0.2865		0.3025	0.2825		0.306	0.2785
	0.3025	0.2825		0.306	0.2782		0.3095	0.2742
	0.2963	0.2717		0.2998	0.2674		0.3033	0.2634
DE9	0.299	0.2865	EF9	0.3025	0.2825	FG9	0.306	0.2785
	0.3052	0.2973		0.3087	0.2933		0.3122	0.2893
	0.3087	0.2933		0.3122	0.289		0.3157	0.285
	0.3025	0.2825		0.306	0.2782		0.3095	0.2742
DE10	0.3052	0.2973	EF10	0.3087	0.2933	FG10	0.3122	0.2893
	0.3114	0.3081		0.3149	0.3041		0.3184	0.3001
	0.3149	0.3041		0.3184	0.2998		0.3219	0.2958
	0.3087	0.2933		0.3122	0.289		0.3157	0.285

**[Remarks]:**

1 Measurement uncertainty of the color coordinates:  $\pm 0.003$ . 坐标测量误差  $\pm 0.003$ .

2 All measurements were made under the standardized environment of Our. 所有测试都是基于我司现有的标准测试平台。

Light Intensity rank and bin code 光强等级和 BIN 代码:

(Note: The dotted line product can be customized 注: 虚线产品需定制)

## 1.8 Typical Optical Characteristics Curves 典型光学特性曲线

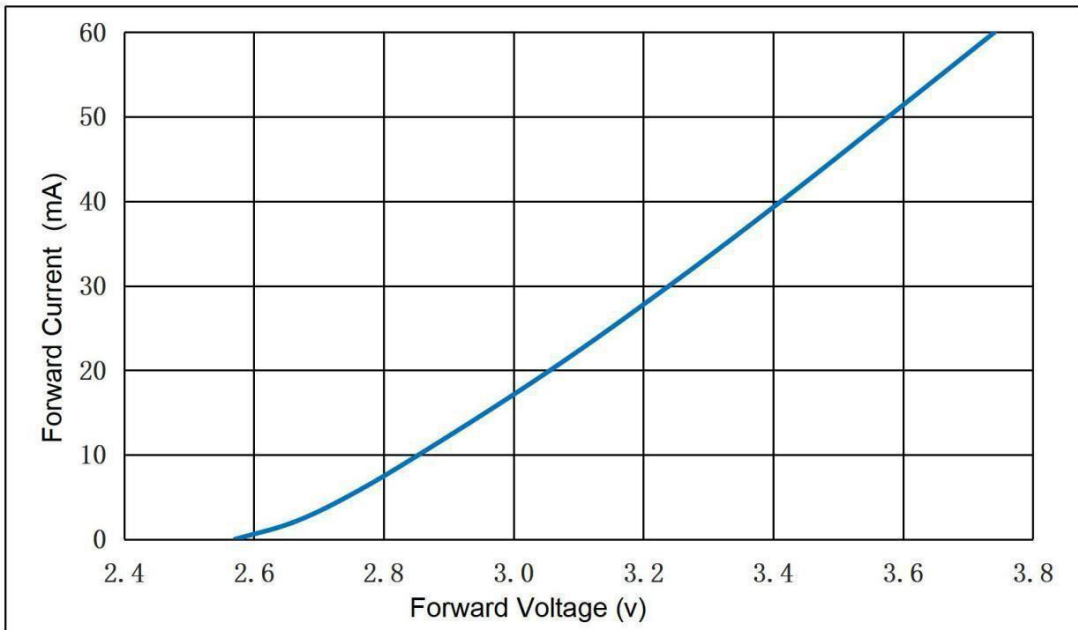

Fig. 1-2 Forward Voltage Vs Forward Current伏安特性曲线

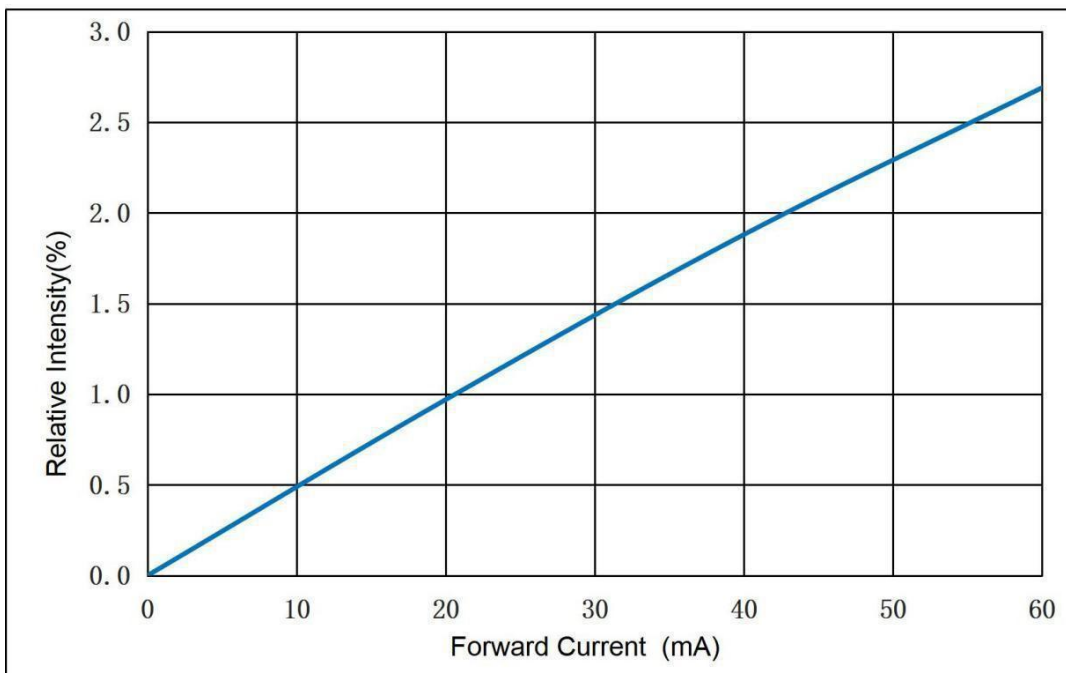

Fig. 1-3 Forward current vs Relative luminous intensity正向电流与相对光强特性曲线

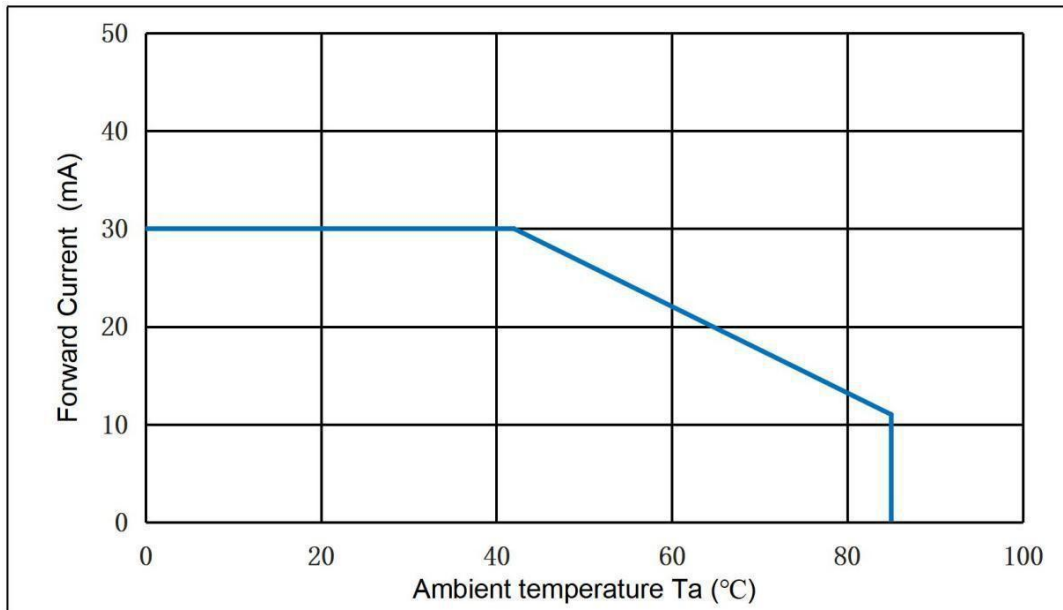

Fig. 1-4 Forward current vs Ambient temperature 管脚温度与正向电流特性曲线

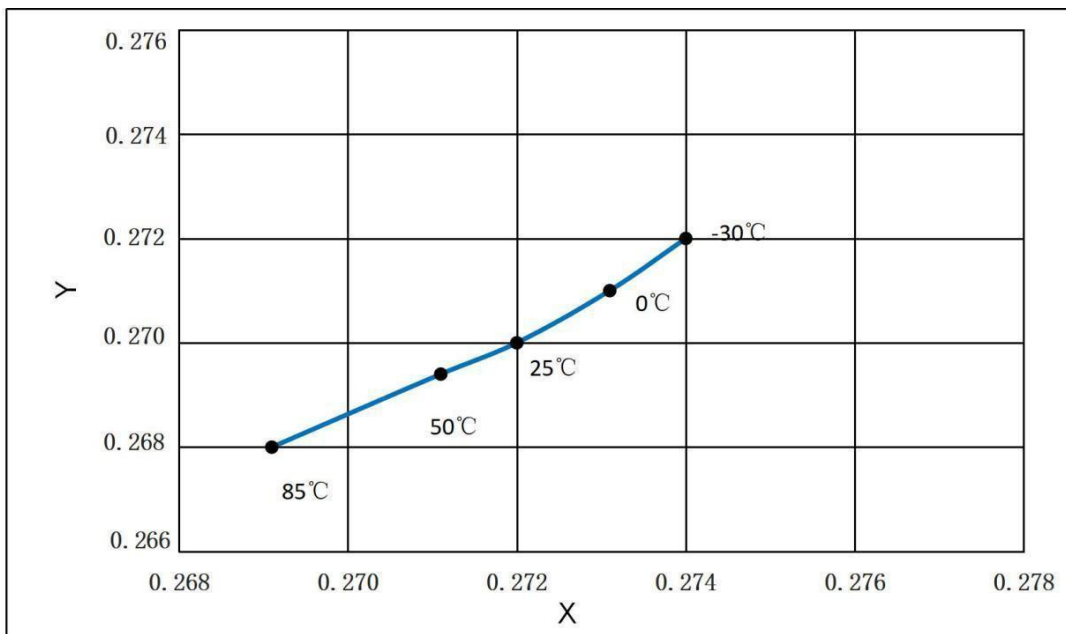

Fig. 1-5 Ambient Temperature vs Chromaticity Coordinate 色坐标与管脚温度特性曲线

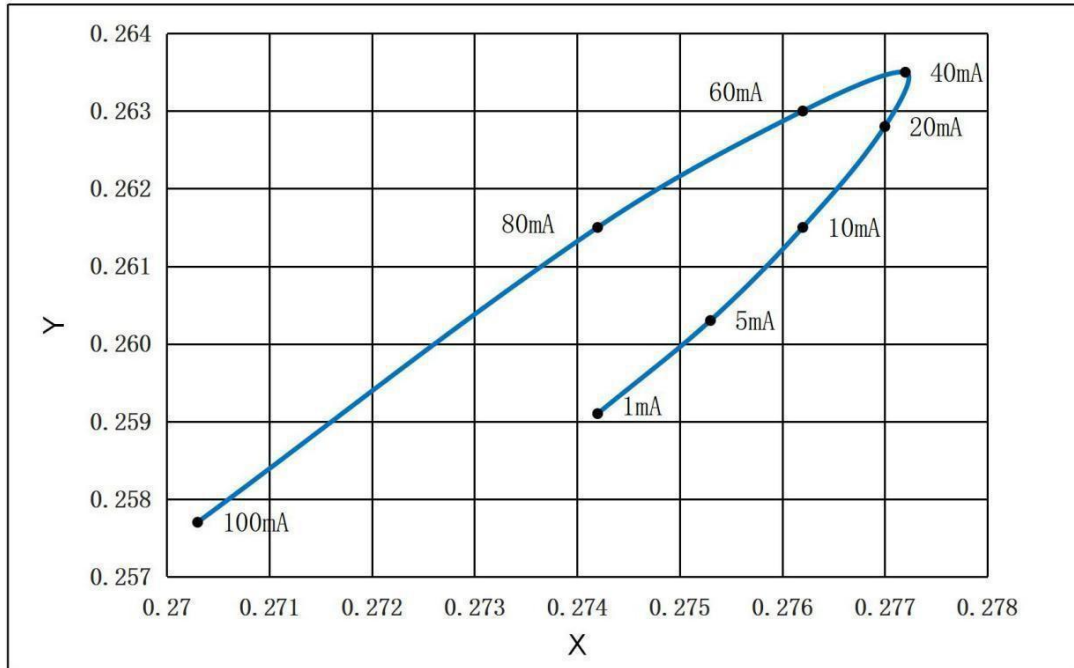

Fig. 1-6 Forward Current vs Chromaticity Coordinate(λD)色度坐标与正向电流曲线

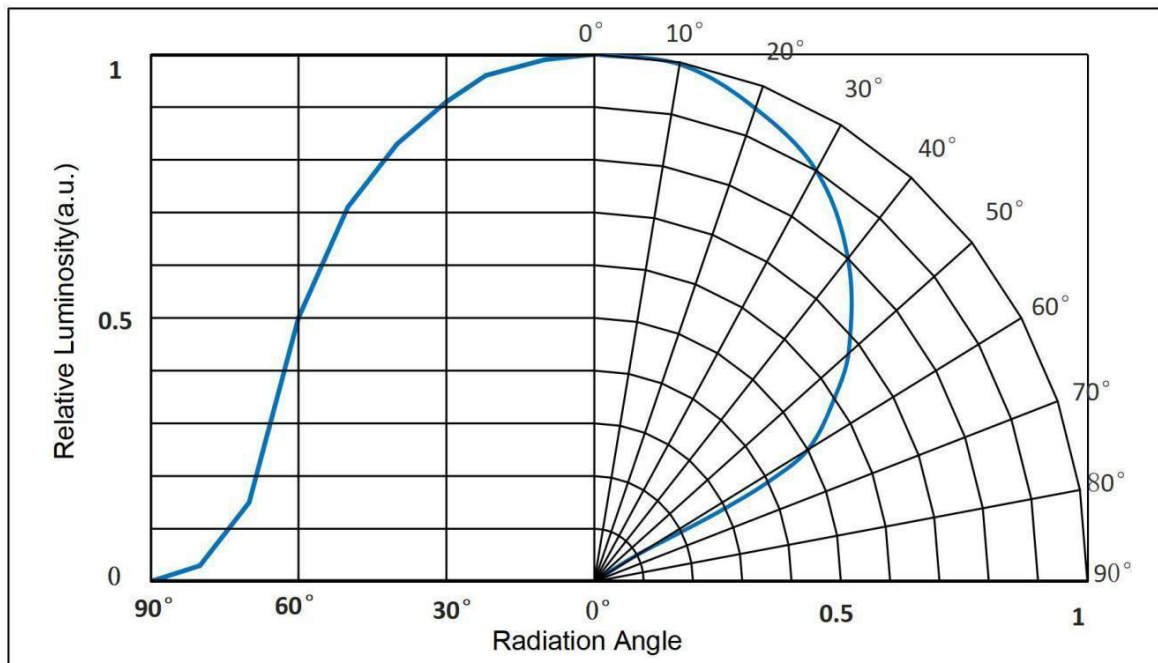

Fig. 1-7 Directivity(Angle:120°)角度与相对光强度曲线

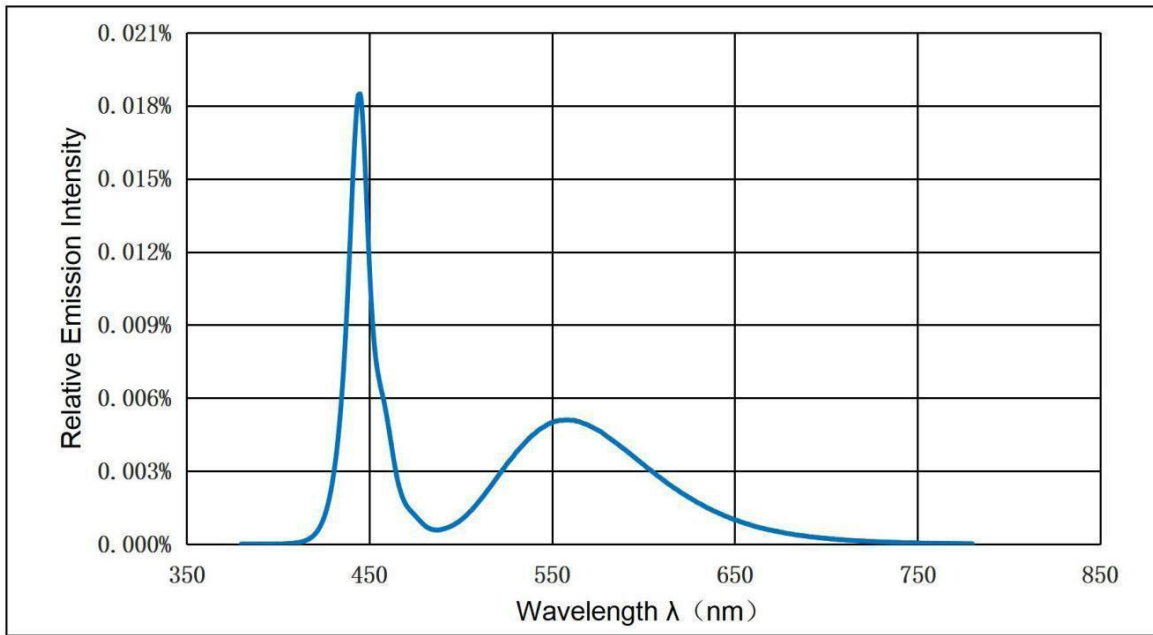

Fig. 1-8 Spectrum Distribution光谱分布特性曲线

## 2. Packaging 产品包装

### 2.1 Packaging Specification 包装规格

Package: 4000pcs/reel. 包装每卷 4000pcs。

#### 2.1.1 Carrier Tape Dimension 载带尺寸

代号	W	A0	B0	K0	E	F	D0	D1	P0	P1	P2	T
尺寸	12±0.20	12±0.1	3.95±0.1	0.75±0.1	175±0.1	5.5±0.1	16±0.1	11±0.1	4.00±0.1	4.00±0.1	2.00±0.05	0.25±0.02

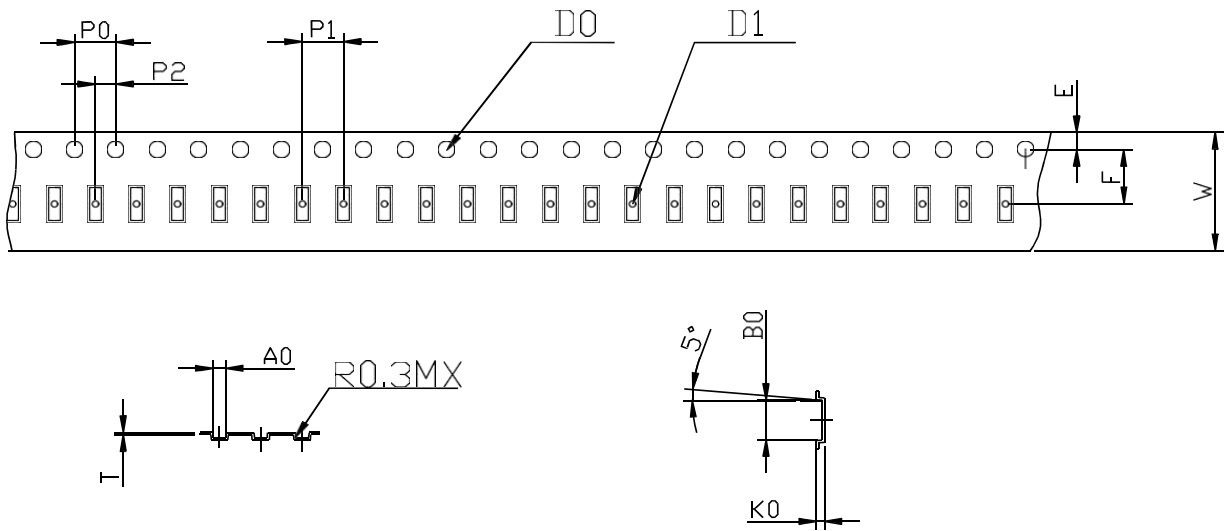

Fig.2-1 Carrier Tape Dimension 载带尺寸

#### 2.1.2 Reel Dimension 卷盘尺寸

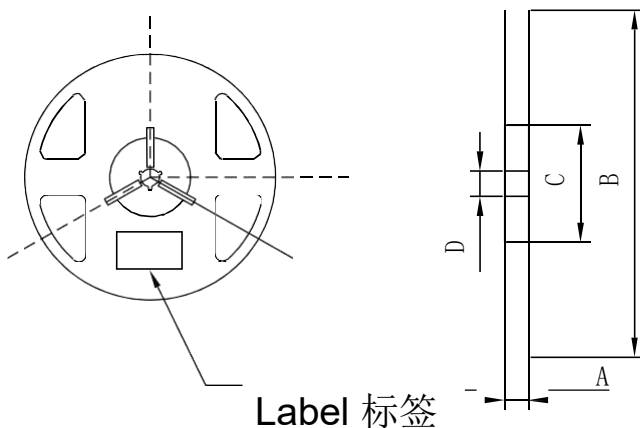

Table 2-1 Title 表名

A	15.2±0.5mm
B	178.0±1mm
C	60.0±0.5mm
D	12.8±0.5mm

Fig.2-2 Reel Dimension 卷盘尺寸

Notes 备注:

The tolerances unless mentioned ±0.1mm. Unit : mm注: 未注公差为±0.1毫米, 尺寸单位: 毫米。

## 2.2 Moisture Resistant Packing 防潮包装

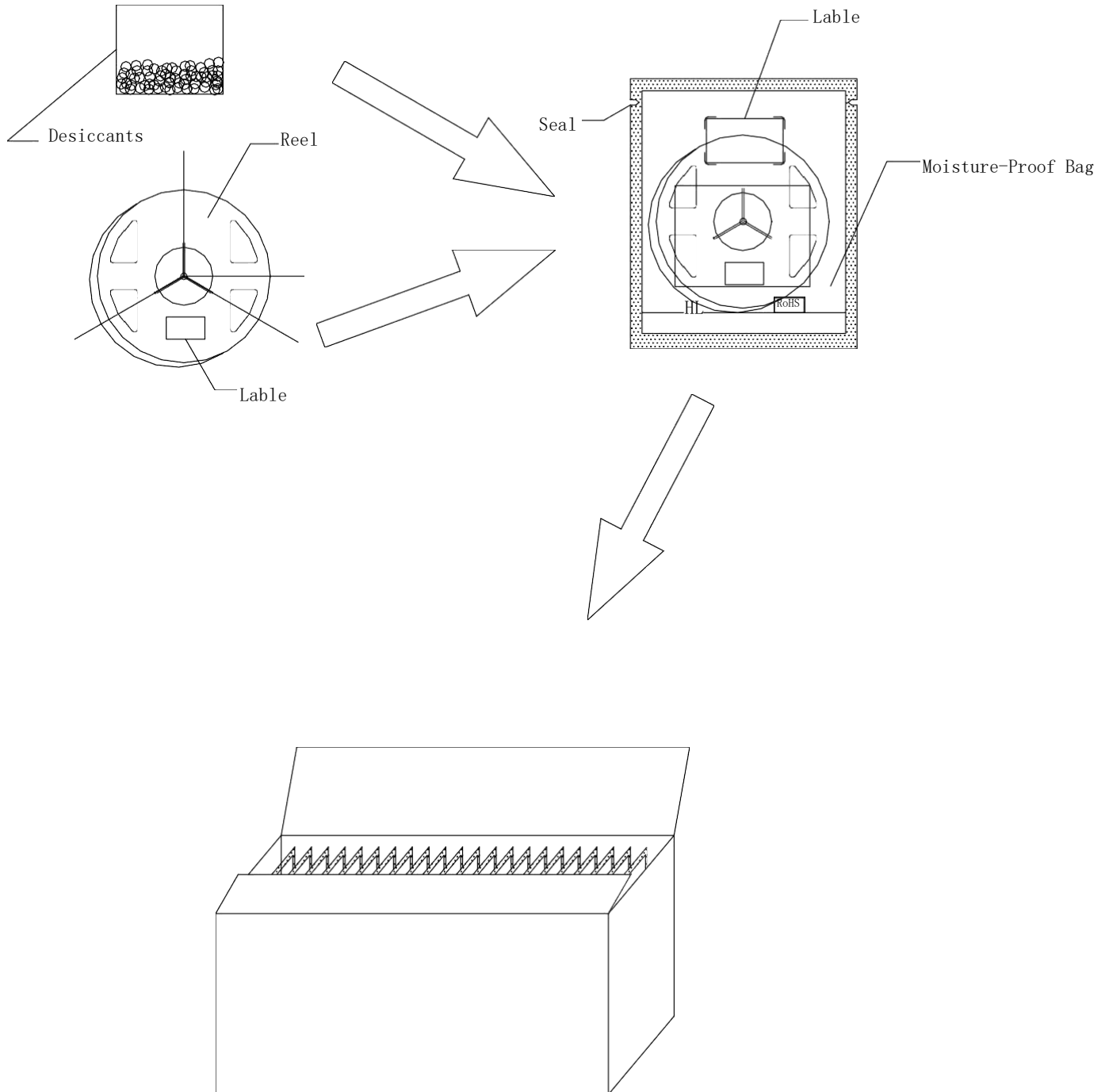

Fig.2-3 Moisture Resistant Packing 防潮包装



## 2.3 Reliability Test Items And Conditions 信赖性测试项目及条件

Test Items 项目	Ref. Standard 参考标准	Test Condition 测试条件	Time 时间	Quantity 数量	Ac/Re 接收/拒收
Reflow 回流焊	B	Temp: 260°C max T=10 sec	----	20 pcs.	0/1
Thermal Shock 冷热冲击	A	-40°C 20min ↑↓10s 100°C 20min	100 cycle	20 pcs.	0/1
High Temperature Storage 高温保存	A	Temp: 100°C	1000 hrs.	20 pcs.	0/1
Low Temperature Storage 低温保存	A	Temp: -40°C	1000 hrs.	20 pcs.	0/1
Life Test 常温测试	A	T <sub>a</sub> =25°C	1000 hrs.	10 pcs.	0/1
High Temperature High Humidity Life Test 高温高湿测试	A	60°C / 90%RH	500 hrs.	10 pcs.	0/1
Temperature Humidity Storage 高温高湿储存	A	T <sub>A</sub> =85°C R <sub>H</sub> =85%	500 hrs.	20 pcs.	0/1

## 2.4 Criteria For Judging Damage 失效判定标准

Test Items 项目	Symbol 符号	Test Condition 测试条件	Criteria For Judgement 判定标准	
			Min. 最小	Max. 最大
Forward Voltage 正向电压	$V_F$	$I_F=20mA$	-	U.S.L*)x1.2
Reverse Current 反向电流	$I_R$	$V_R = 7V$	-	U.S.L*)x2.0
Luminous Flux 光通量	$\Phi$	$I_F=20mA$	L.S.L*)x0.7	-

Notes 备注:

1.U.S.L: Upper standard level 规格上限 L.S.L: Lower standard level 规格下限

2. The above reliability tests is based on the verification of a single/strip LED of existing experimental platform,the reliability experiment was taken under good heat dissipation conditions. when customers applies the LED to the series and parallel circuit, should take consideration of all the factors such as the current, voltage distribution, heat dissipation and others.以上可靠性测试是基于现有实验平台单颗/条LED 在良好散热条件验证下的结果。客户端将 LED 应用于串、并联线路时，需自行评估电流、电压分配、散热等问题。

3. The technical information shown in the data sheets is limited to the typical characteristics and circuit examples of the referenced products. It does not constitute the warranting of industrial property nor the granting of any license. 以上技术数据仅为产品的典型值，只作为参考，不作为任何应用条件及应用方式的保证。

### 3. SMT Reflow Soldering Instructions SMT 回流焊说明

#### 3.1 SMT Reflow Soldering Instructions SMT 回流焊说明

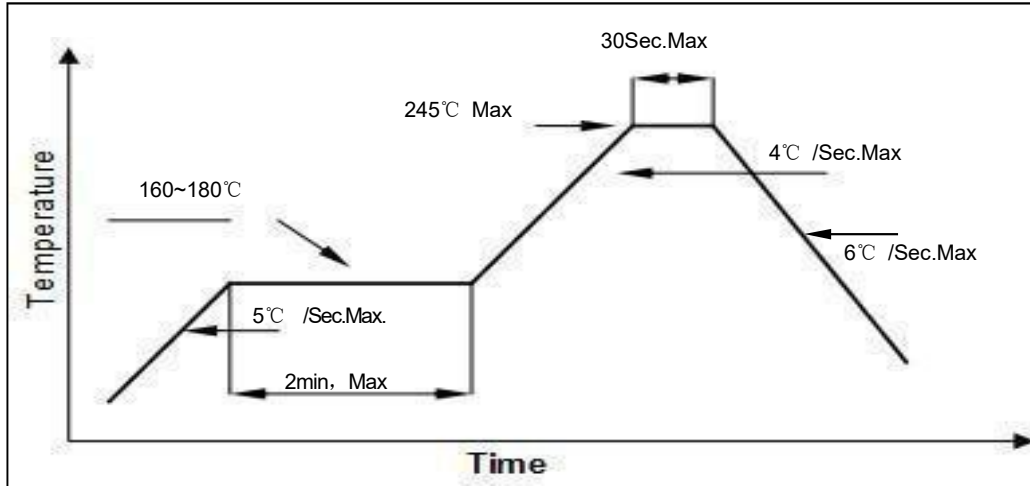

##### 3.1.1 Soldering Iron 烙铁焊接

(1) When do soldering by hand, keep the temperature of iron below less 300°C less than 3 seconds. 当手工焊接时, 烙铁的温度必须小于300°C, 时间不可超过3秒。

Soldering by hand should be done only one time. 手工焊接只可焊接一次。

##### 3.1.2 Repairing 修补

Repairing should not be done after the LEDs have been soldered. When repairing is unavoidable, a double-head soldering iron should be used (as below figure). It should be confirmed in advance whether the characteristics of LEDs will or not be damaged by repairing.

LED回流焊后不应该修复, 当必须修复时, 必须使用双头烙铁, 而且事先应确认此种方式会不会损坏LED本身的特性。

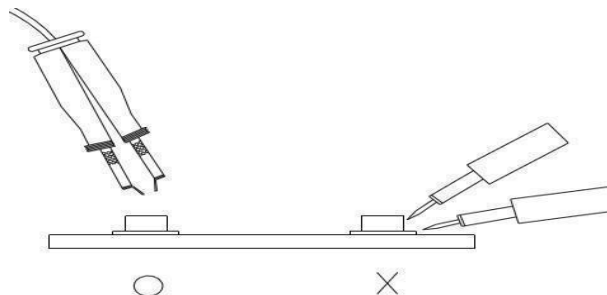

Fig 3-2 Repairing 修补

### 3.1.3 Cautions 注意事项

(1) The encapsulated material of the LEDs is silicone. Therefore the LEDs have a soft surface on the top of package. The pressure to the top surface will be impacted on the reliability of the LEDs. Precautions should be taken to avoid the strong pressure on the encapsulated part. So when use the picking up nozzle, the pressure on the silicone resin should be proper. LED封装胶为硅胶，表面较软，用力按压胶体表面会影响LED可靠性，因此应有预防措施避免在按压器件，当使用吸嘴时，胶体表面的压力应是恰当的。

(2) Components should not be mounted on warped (non coplanar) portion of PCB. After soldering, do not warp the circuit board. LED 灯珠不要焊接在弯曲的 PCB 板上，焊接之后，也不要弯折线路板。

(3) Do not apply mechanical force or excess vibration during the cooling process to normal temperature after soldering. Do not rapidly cool device after soldering. 回流焊之后冷却过程中，不要对材料施加外力，也不要震动，回流焊后，不要采用激剧冷却的方式。

## 4. Handling Precautions 产品使用注意事项

### 4.1 Handling Precautions 产品使用注意事项

(1) LED operating environment and sulfur element composition cannot be over 100PPM in the LED mating usage material. This is provided for informational purposes only and is not a warranty or endorsement. LED 工作环境及与 LED 适配的材料中硫元素及化合物成份不可超过 100PPM. 这只是一个建议，不作任何品质担保。

(2) In order to prevent external material from getting into the inside of LED, which may cause the malfunction of LED, the single content of Bromine element is required to be less than 900PPM, the single content of Chlorine element is required to be less than 900PPM, the total content of Bromine element and Chlorine element in the external materials of the application products is required to be less than 1500PPM. This is provided for informational purposes only and is not a warranty or endorsement. 为了防止外界物质进入 LED 内部以造成 LED 的损伤，所处环境及所用套件等等，单一的溴元素含量要求小于 900PPM，单一氯元素含量要求小于 900PPM，溴元素与氯元素总含量必须小于 1500PPM. 这只是一个建议，不作任何品质担保。

(3) Handle the component along the side surface by using forceps or appropriate tools; do not directly touch or Handle the silicone lens surface, it may damage the internal circuitry. 通过使用适当的工具从材料侧面夹取，不可直接用手或尖锐金属压胶体表面，它可能会损坏内部电路。

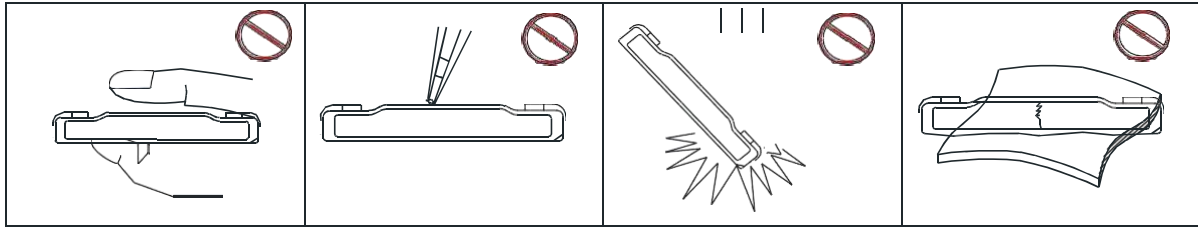

Fig 4-1 Handling Precautions 产品使用注意事项

(4) In designing a circuit, the current through each LED must exceed the absolute maximum rating specified for each LED. In the meanwhile, resistors for protection should be applied, otherwise slight voltage shift will cause big current change, burn out may happen. The driving circuit must be designed to allow forward voltage only when it is ON or OFF. If the reverse voltage is applied to LED, migration can be generated resulting in LED damage. 设计电路时，通过 LED 的电流不能超过规定的最大值，同时，还需使用保护电阻，否则，微小的电压变化将会引起较大电流变化，可能导致产品损毁。电路设计必须保证只有在开启或者关闭的时候出现正向电压的变化，不要施加反压，否则会损坏 LED。

(5) Thermal Design is paramount importance because heat generation may result in the Characteristics decline, such as brightness decreased, Color change and so on. Please consider the heat generation of the LEDs when making the system design. LED 容易因为自身的发热和环境的温度改变而改变，温度升高会降低 LED 发光效率，影响发光颜色，所以在设计时应充分考虑散热问题。

(6) Compared to standard encapsulants, silicone is generally softer, and the surface is more likely to attract dust, requiring special care during processing. In cases where a minimal level of dirt and dust particles cannot be guaranteed, a suitable cleaning solution must be applied to the surface after the soldering of components. Refond suggests using isopropyl alcohol for cleaning. In case other solvents are used, it must be assured that these solvents do not dissolve the package or resin. Ultrasonic cleaning is not recommended. Ultrasonic cleaning may cause damage to the LED. 与其他封装胶相比，硅胶通常较软，表面易吸附脏物，应用时应特别注意，当对产品洁净度要求较高时，回流焊以后需要采用恰当的清洗方式，我们推荐用异丙醇作清洗剂，如

需要用到其他清洗剂，必须保证不会破坏封装体，超声清洗可能会对 LED 带来损害，不推荐这种清洗方式。

(7) If the moisture absorbent material (silica gel) has faded away or the LEDs have exceeded the storage time, baking conditions are as follows: the coil is baked at  $65 \pm 5^{\circ}\text{C}$  for 4 hours, the bulk material is baked at  $130 \pm 5^{\circ}\text{C}$  for 3 hours. 如果干燥剂或包装失效，或者产品不符合以上有效储存条件，需拆包后进行烘烤，烘烤条件：卷料  $65 \pm 5^{\circ}\text{C}$ ，4 小时，散料  $130 \pm 5^{\circ}\text{C}$ ，3 小时。

If the package is flatulence or damaged, please notify the sales staff to assist. 如果包装胀气或者破损，请通知销售人员协助处理。

(9) Similar to most Solid state devices; LEDs are sensitive to Electro-Static Discharge (ESD) and Electrical Over Stress (EOS). 像其他的半导体电子器件一样，LED 对静电过流击穿非常敏感，需要做好防护。

Conditions		Temperature	Humidity	Time
种类		温度	湿度	时间
Storage 储存	Before Opening Aluminum Bag 拆包前	$\leq 30^{\circ}\text{C}$	$\leq 75\%$	1 Year 一年内
	After Opening Aluminum Bag 拆包后	$\leq 30^{\circ}\text{C}$	$\leq 60\%$	24hours 7days
Baking 烘烤		卷料： $65 \pm 5^{\circ}\text{C}$	-----	4 hours
		散料： $130 \pm 5^{\circ}\text{C}$		3 hours

Table 4-1 Storage 储存