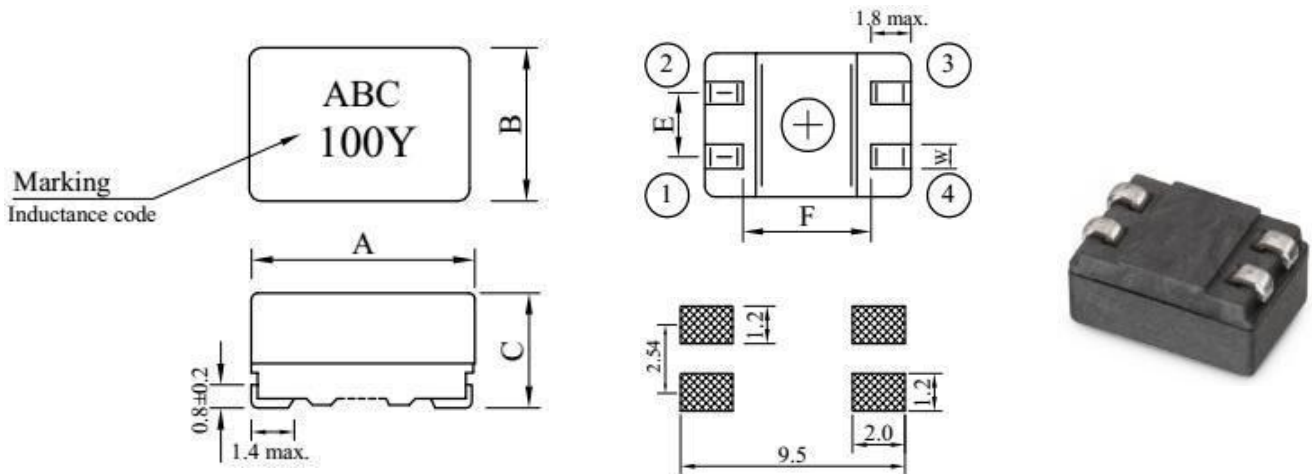
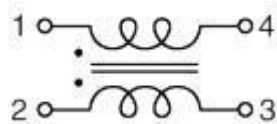

SHAPE & DIMENSION (UNIT:mm)

ITEM	A	B	C	R	F	W
DIM	9.2	6.0	5.0	2.54	5.70	1.0
TOLE	±0.3	±0.3	±0.3	±0.2	Ref	±0.1

ELECREICAL SCHEMATIC:

Part Number	Inductance L1=L2 (uH)	Test Frequency	DC Resistance 1-4,2-3 (Ω) Max.	Rated Current (A) Max.	Rated Volt. (Vdc)Max.	IR (Ω)min.
SMW9050S100NTT	10±30%	1KHz/0.1V	0.08	1.6	80	10M
SMW9050S250NTT	25±30%	1KHz/0.1V	0.16	1.0	80	10M
SMW9050S400NTT	40±30%	1KHz/0.1V	0.25	0.9	80	10M
SMW9050S510NTT	51±30%	1KHz/0.1V	0.32	0.8	80	10M
SMW9050S251ZTT	250±50%	100KHz/5mV	0.13	1.2	80	10M
SMW9050S471ZTT	470±50%	100KHz/5mV	0.14	1.1	80	10M
SMW9050S501ZTT	500±50%	100KHz/5mV	0.15	1.0	80	10M
SMW9050S102ZTT	1000±50%	100KHz/5mV	0.31	0.8	80	10M
SMW9050S202ZTT	2000±50%	100KHz/5mV	0.42	0.6	80	10M
SMW9050S472ZTT	4700±50%	100KHz/5mV	0.90	0.4	80	10M
SMW9050S652ZTT	6500±50%	100KHz/5mV	1.05	0.3	80	10M

- (1).Rated Current: Temp.rise 40°C Typ
- (2).Operating Temperature: -20°C up to +80°C
- (3).Storage Temperature: -20°C up to +40°C, 75% RH max.

RELIABILITY TEST

Test Items	Test Conditions	Criteria
1. Low temperature storage	Placed at -40°C for 500 hours, then measured at room ambient temperature after placing 24 hours.	Inductance shall be within ±10% of the initial value.
2. High temperature storage	Placed at +125°C for 500 hours, then measured at room ambient temperature after placing 24 hours.	Inductance shall be within ±10% of the initial value.
3. Thermal shock	-40°C, 30min. ~ +125°C, 30min., 500hours	Inductance shall be within ±10% of the initial value.
4. Humidity resistance	Placed at 90 to 95%RH, +50°C for 500 hours, then measured at room ambient temperature after placing 24 hours.	Inductance shall be within ±10% of the initial value. Insulation resistance > 100Mohm at DC
5. Drop	Drop specimen three times on concrete floor from a height of 1 meter which mounted on test board.	Inductance shall be within ±10% of the initial value.
6. Vibration	Frequency: 10~500Hz Amplitude: 1.5mm or 10G Sweep time: 1oct/min Test Directions: X,Y,Z Test Time: 2 hours each direction	Inductance shall be within ±10% of the initial value.
7. Terminal strength	Add static load 4.9N (500gf) to inductor through hole of test board for 10±2 sec.	No detachment of terminal pin and no breakage of wire.
8. Soldering heat resistance	Dip inductor's terminal in solder bath of following conditions: 1) 260±5°C, 10±1sec, 2) 350±10°C, 3.5±0.5sec	Inductance shall be within ±10% of the initial value. Appearance: No damage

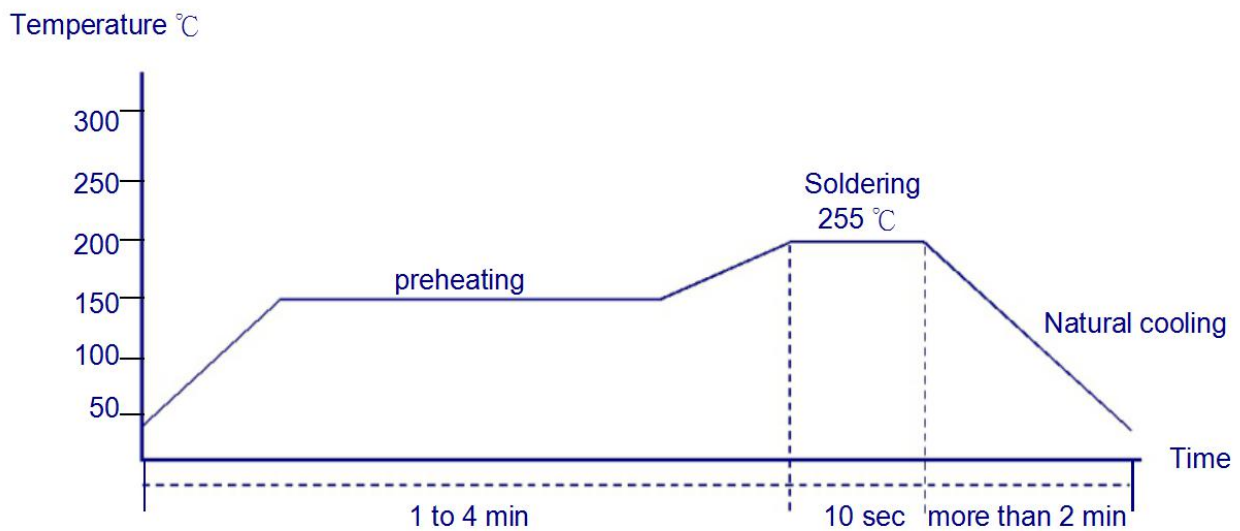
REFLOW-PROFILE

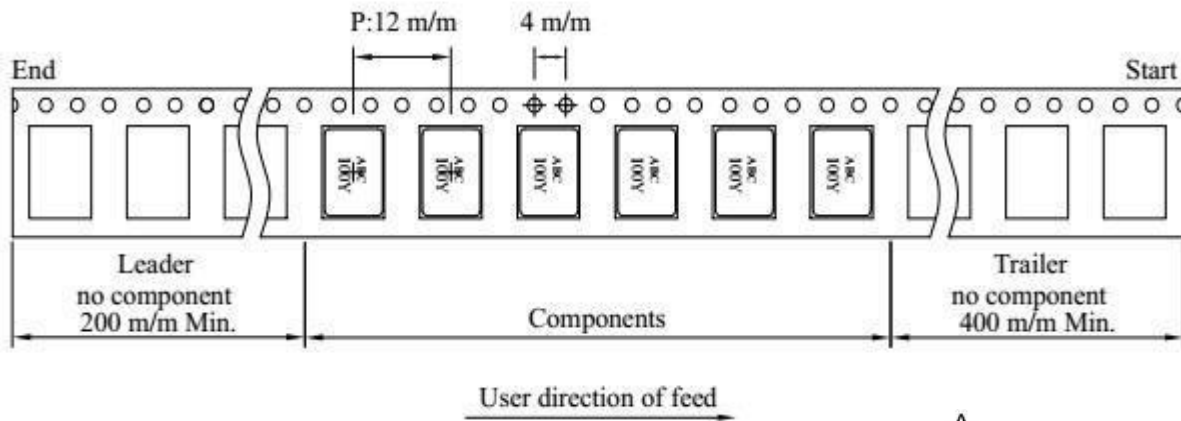
PACKAGING

Tape width	Distance	Pull-of force
16 mm	12mm	10~130g

透明下帶，自粘上帶

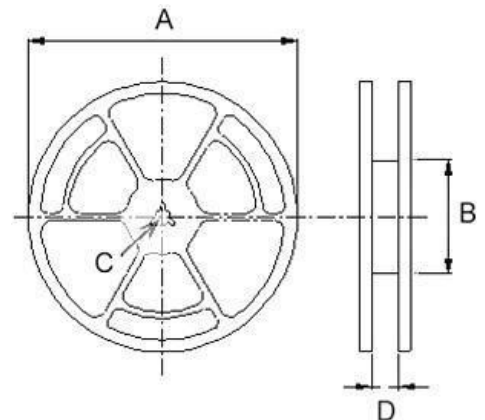
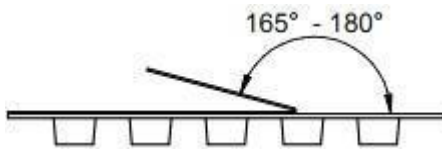

Reel Dimensions(Unit:mm)				Quantity
A	B	C	D	Pcs/Reel
330	100	13	16.5	1000