

承认书

APPROVAL SHEET

客户
Customer :

品名
Description : 固体电解质铝电解电容器(E-CAP)

客户料号
Part No. :

瑞隆料号
Ruiling Part No. : 8470MAM1013H2RR000

商标
Brand : RLH2

系列
Series : H2

规格
Specification : 47 μ F/100V Φ 10*13L

形状
Type : 导针型

供应商 Vendor		客户 Customer	
核准 Approver	编制 Designer	核准 Approver	检验 Check
伍伟桥	谭艳		

承认后，请签回一份，在下正式订单前如未签回承认书，视同默认本公司的相关标准及技术指标。
After approved, please sign back 1 Approval Sheet before order. If not, we will treat it as tacitly acknowledged and accepted our relative standard and technical index.

肇庆市瑞隆电子有限公司

Zhao Qing Ruiling Electronic Co. Ltd

中国广东省肇庆市端州八路

No.8, duozhou, zhaqing city, guangdong province, China

TEL: (0758) 6923097

FAX: (0758) 6923096



H2 Series

- Low ESR, high ripple current, high voltage
- Load life of 2000 hours at 105°C
- RoHS Compliant

◆ 规格表 Specifications

项目 Items	特性参数 Characteristics		
使用温度范围 Category Temperature Range	-55 ~ +105°C		
额定工作电压范围 Rated Voltage Range	35 ~ 100V		
静电容量允许偏差 Capacitance tolerance	±20%(M) (at 20°C, 120Hz)		
漏电流 Leakage Current	施加额定工作电压2分钟后读数, 小于或等于规格值 (at 20°C) I ≤ 0.1CV 或 299µA (取大值) Less than or equal to the specified value. After 2 minutes application of rated Voltage at 20°C		
损耗角正切值 tanδ Dissipation Factor	Rated voltage (V)	35~100	(at 20°C, 120Hz)
	tanδ (Max.)	0.12	
温度特性 Low Temperature Characteristics (Max. Impedance Ratio)	Z(-25°C)/Z(+20°C)	≤ 1.25	(100KHz)
	Z(-55°C)/Z(+20°C)	≤ 1.25	
耐久性 Endurance	105°C 施加额定工作电压2000小时, 恢复到20°C后, 产品性能应满足以下要求 The specifications listed below shall be satisfied when the capacitors are restored to 20°C after application of rated voltage for 2000 hours at 105°C.		
	Appearance	No significant damage	
	Capacitance change	≤ ±20% of the initial value	
	D.F.(tanδ)	≤ 150% of the specified value	
	ESR	≤ 150% of the specified value	
	Leakage current	≤ The specified value	
耐湿负荷特性 Damp Heat (Steady State)	在60°C 温度, 湿度90%~95%RH的环境中, 施加额定电压1000小时后, 恢复到20°C后, 产品性能应满足以下要求 The specifications listed below shall be satisfied when the capacitors are restored to 20°C after application of rated voltage for 1000 hours at 60°C, 90% ~ 95% RH.		
	Appearance	No significant damage	
	Capacitance change	≤ ±20% of the initial value	
	D.F.(tanδ)	≤ 150% of the specified value	
	ESR	≤ 150% of the specified value	
	Leakage current	≤ The specified value	
浪涌电压特性 (Surge Voltage)	浪涌电压=额定电压× 1.15(V) Surge Voltage=Rated voltage × 1.15(V) 在105°C环境中, 按充电30秒; 放电5分30秒, 连续施加浪涌电压1000次(Rc=1kΩ), 待恢复后测试, 应满足以下要求 The capacitors shall be subjected to 1000 cycles each consisting of charge with the surge voltages specified at 105°C for 30 seconds through a protective resistor (Rc=1kΩ) and discharge for 5 minutes 30 seconds		
	Appearance	No significant damage	
	Capacitance change	≤ ±20% of the initial value	
	D.F.(tanδ)	≤ 150% of the specified value	
	ESR	≤ 150% of the specified value	
	Leakage current	≤ The specified value	

◆ 外形图 Dimensions (mm)

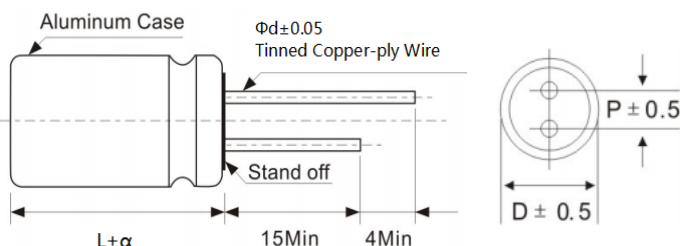

ΦD	5	6.3	8	10
P	2.0	2.5	3.5	5.0
Φd	0.5	0.6	0.6	0.6

α	(L < 16) 1.0
	(16 ≤ L < 22) 1.5
	(L ≥ 22) 2.0

基本特性参数表 Characteristics

Series	Capacitance. (uF) 120Hz/+20°C	Capacitance Tolerance. (%) 120Hz/+20°C	Rated Voltage (VDC)	Surge Voltage (VDC)	Dissipation Factor 120Hz/+20°C	Leakage Current 2min(uA) +20°C	ESR 100KHz +20°C(m Ω)	Ripple Current. 100KHz (mArms)
H2	47	±20	100	115.0	0.12	630	40	2500

Load Life (Hrs)	Diameter (mm)		Length (mm)		Pitch (mm)		Wire Diameter (mm)		Colour 红色	Process	
	D	Tolerance	L	Tolerance	P	Tolerance	Φd	Tolerance		Type	dimension parameter
2000	10	±0.5	13	±1.0	5	±0.5	0.6	±0.05		长脚	/

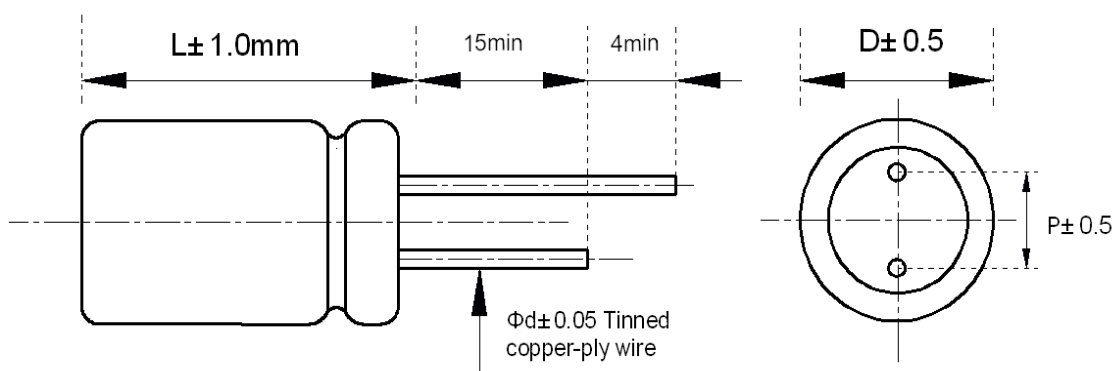

◆纹波电流修正系数 Rated Ripple Current Coefficient

频率Frequency(Hz)	$120\text{Hz} \leq F < 1\text{KHz}$	$1\text{KHz} \leq F < 10\text{KHz}$	$10\text{KHz} \leq F < 100\text{KHz}$	$100\text{KHz} \leq F < 500\text{KHz}$
系数Case code	0.05	0.30	0.70	1.00

◆料号说明 Explanation of parts numbers

8 4 7 0 M A M 1 0 1 3 H 2 R R 0 0 O

代码 Code	产品类别 Type
8	成品 Product

代码 Code	电压 Voltage
LJ	2.5V
LO	4V
LA	6.3V
LM	6.8V
LK	7.5V
LB	10V
LL	12V
LC	16V
LN	20V
LD	25V
LE	35V
LF	50V
LG	63V
LH	80V
MA	100V
MR	110V
MG	120V
MH	125V
MV	130V
MB	160V
MY	180V
MC	200V

代码 Code	尺寸Φ Dimensions DxL(mm)
0505	Φ5x5.5
0507	Φ5x7
0509	Φ5x9
AA05	Φ6.3x5.5
AA07	Φ6.3x7
AA09	Φ6.3x9
AA11	Φ6.3x11
0808	Φ8x8
0812	Φ8x12
10AF	Φ10x11.5
1013	Φ10x13
10AG	Φ10x16.5
1321	Φ13x21

代码 Code	客户代码 Customer code
R	Ruilong

代码 Code	电压 Voltage
O	散装 Bagged
T	贴片 SMD

代码 Code	标称容量 Nominal Capacita nce
R22	0.22μF
1R0	1μF
2R2	2.2μF
220	22μF
221	220μF
222	2200μF
470	47μF

代码 Code	颜色 Color
B	蓝色 Blue
R	红色 Red
G	灰色 Gary

代码 Code	识别码 Identifier
00	正常品 Ichiban

代码 Code	误差 Tolerance
J	±5%
K	±10%
V	-10~+20%
M	±20%
Q	-10~+30%
T	-10~+50%
Z	-20~+80%
A	特殊 Special

代码 Code	温度 Temperatrue	描述 Description
E1	-55~+105	寿命: 2000小时 低阻抗插件式产品
E2	-55~+105	寿命: 2000小时 插件式标准品
E5	-55~+105	寿命: 5000小时 插件式长寿命产品
M1	-55~+105	寿命: 2000小时 低阻抗贴片式产品
M2	-55~+105	寿命: 2000小时 贴片式标准品
M5	-55~+105	寿命: 5000小时 贴片式长寿命产品
H1	-55~+105	寿命: 2000小时 高压低阻抗插件式产品
H2	-55~+105	寿命: 2000小时 高压插件式标准品
H5	-55~+105	寿命: 5000小时 高压插件式长寿命产品

The structure chart of solid electrolytic capacitors 固态电容器结构图

Capacitor
电容器

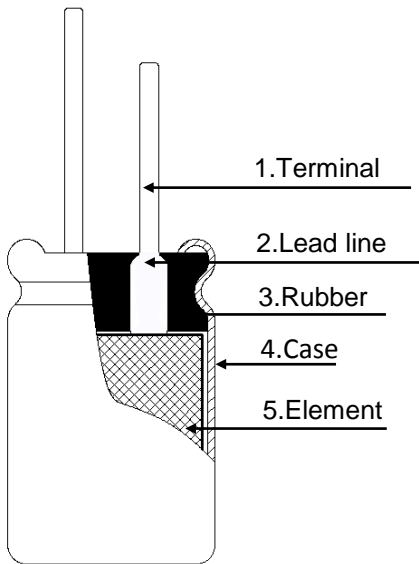

Stretch Out View of Element
素子展开图

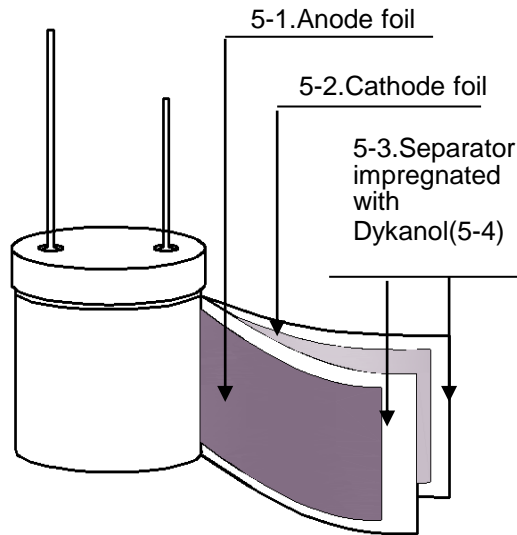

Cross Section of Terminal
CP 线横向剖面图

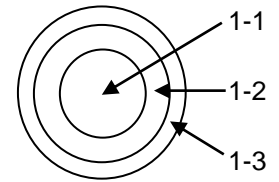

1-1. Fe
铁芯

1-2. Copper plate (≥10um)
镀铜层

1-3. Tin Plate (≥8um)
镀锡层

Item	Component 组成材料	Materials 材质	Vendor 供应商
1	Terminal CP线	Tinned copper-ply wire 镀铜镀锡铁线	Japan-Funded Enterprises
2	Lead line 引出线	Aluminum, 99.95% or 99.97% 纯度为99.95%或99.97%的金属铝片	Ri hui
3	Rubber 胶盖	RE IIR rubber RE IIR 橡胶	Lian Hua Xin
4	Case 铝壳	Aluminum, 99.8% 纯度为99.8%的金属铝	YI Peng、Xie Sheng
5-1	Anode Foil 阳极箔	Formed aluminum, 99.99% or 99.98% 纯度99.99%或99.98%的化成铝箔	JCC、Fu Qi
5-2	Cathode Foil 阴极箔	Etched aluminum, 99.7% or 99.4% 纯度99.7%或99.4%的腐蚀铝箔	Nanofoil
5-3	Separator 电解纸	Manila,pulp,kraft,etc. 马尼拉纸、纸浆、牛皮纸等	KAN、NKK
5-4	Dykanol 介质材料	Poly3,4-Ethylene Dioxy Thiophene 聚3, 4-乙烷基二氧噻吩	Rui Long

◆ 操作注意事项 Operating Precautions

1、极性Polarity

瑞隆电容器是具有正负极的固态铝电解电容，使用中不可反接，若接反，则电容会因为漏电流不断增大或短路而造成寿命缩短。

RuilongCAP is a solid aluminum electrolytic capacitor with positive and negative electrodes. Do not reverse the polarity when using. If it is used with the polarities reversed, its life may shorten because of increasing leakage current or short circuit.

2、禁止电路 Prohibited circuits

因为焊接及其它动作可造成电容的漏电流增加，瑞隆电容器不可使用在下列电路中：

Since problems can be expected due to leakage current increasing during soldering and other processes, Ruilong CAP cannot be used in the following circuits:

- 1)高阻抗电路 High impedance circuits;
- 2)耦合电路 Coupling circuits;
- 3)时间常数电路 Time constant circuits;
- 4)为提高耐电压而串联两个或多个电容于电路中

Connection of two or more capacitors in series for higher withstand voltage;

- 5)电路因漏电流过大而有坏的影响 Circuits to get bad influence by big leakage current

*除漏电流的波动上升外，电容的使用条件如在承认书中规定的高温 and 低温，温热和耐受性条件都会影响电容量。若电容作为时间常数电路使用，因其对电容量的变动的敏感性，电容量的改变会造成影响。若要将其作为时间常数电路使用，同时若因电压原因要串联多个电容，请联系敝司。

* In addition to the leakage current fluctuation above, the operational conditions such as characteristics at high and low temperature, damp heat and endurance stipulated in the specifications will affect the capacitance. The fluctuation of the capacitance may cause problem if it is used as a time constant capacitor, which is extremely sensitive to the fluctuation of the capacitance. Do not use it as a time constant capacitor. Additionally, please contact our company. for usage of two or more capacitor in series for voltage proof.

3、电压 Over voltage

电压若超过额定电压，即便只是一瞬间也可能造成短路

Over voltage exceeding the rated voltage may not be applied even for an instant as it may cause a short circuit.

4、突然充放电 Sudden charge and discharge

突然的充放电是不可取的（为了维持高的可靠性）。为防止突然的充放电造成电容短路或漏电增大，电路中应加上一个保护电路用以分流过大的电流。若瞬间电流超过10A或超过10倍允许纹波电流，要使用保护电路。在测试漏电流时请加上一个1kΩ的电阻用以充放电。

Sudden charge and discharge restricted (for maintenance of high-proof reliability). A protection circuit is recommended for when a sudden charge or discharge causes excessive rush current because this is a main cause of short circuits and large leakage current. Use protection circuits if the rush current exceeds 10A. The rush current exceeds 10×the maximum allowable ripple current of capacitor. Be sure to insert a protection resistor of about 1kΩ for charge and discharge when measuring the leakage current.

5、使用温度和纹波电流 Operating temperature and ripple current

如果电容器的使用温度超过了上限温度或是有过载纹波电流通过，则有较大可能使电容器寿命缩短，或漏电流增大，造成电容器失效。

If capacitor is used at a temperature higher than the upper category temperature, or excess ripple current flows through capacitor, there are high possibilities of life cycle reduction or leakage current increasing to cause capacitor defective.

6、漏电流 Leakage current

漏电流会因焊接条件而有些微的上升，加载直流电压可使电容自我修复，漏电流逐渐减小。

The leakage current of capacitor may increase slightly by soldering conditions. The application of DC voltage enables the capacitors to be repaired by itself and this leads the leakage current to be smaller gradually.

7、使用电压 Applied voltage

为了保证瑞隆电容器的可靠性，加载到瑞隆电容器上的电压最好小于其额定电压的80%。直流加交流电压的峰值应小于额定电压。

For the reliability of RuilongCAP, it is recommended that the voltage applied to RuilongCAP should be less than 80% of the rated voltage. Peak value of the dc and ac voltage should not exceed its rated voltage.

◆ 标示 Marking

每个部品的表面或最小包装单位依下记事项不易消失的方法来标示。

The following items shall be marked indelibly and legibly on specimen or each unit pack.

1. 系列和商标 Series and trademark.
2. 静电容量 Capacitance
3. 额定电压 Work voltage
4. 负极性 Negative polarity

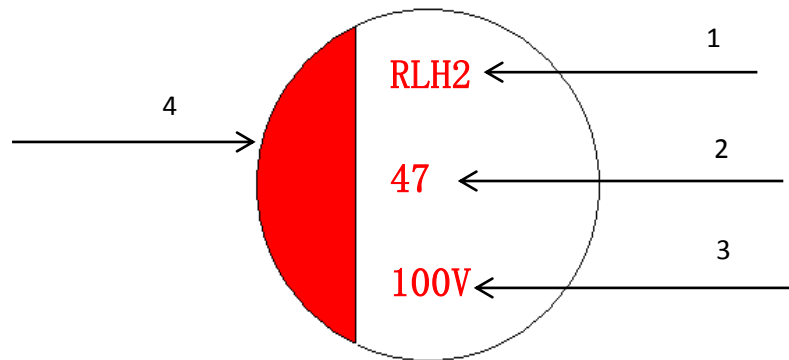

注：

1. 本承认书中所有数据如有异议，以中文为准。
2. 在使用电解电容器时，请参考承认书内的使用标准，由于客户使用超出承认书相关参数和范围，如额定电压、额定纹波电流、温度等，不在我司质量保证范围内。
3. 由于电路设计不当或缺陷造成的电解电容器损坏，不在我司质量保证范围内。
4. 由于固态电容设计的特点不同，为不影响电容性能，要注意电容脚距的匹配性，在测试和使用电容引脚不能受到机械外力引起电容脚距发生变化。

固态电容器检查表

TEST REPORT FOR ELEC CAPACITORS

Customer

客户: _____ Series: H2

Specification

规格: 47 uF 100 V

Size

尺寸: D 10 Φ×L 13

1. Temperature Range 温度: -55~+105°C
2. Capacitance Tolerance 静电容量容许差: ±20%
3. Leakage Current: I≤0.1CV or 299μA(After 2 minutes application of rated voltage)
4. Testme: ZENTECH CLC-201 NF ZM-2355
5. Test Temperayure: 20°C

项目 Spec规格值 NO. 号码	Cap 静电容量	D.F 损失角	L.C. 漏电流	ESR 等效串联阻抗	Soldeta- bility 焊锡性	Appearance 外观		
	37.6 ~ 56.4 (uF)	At 120 Hz 0.12max	470 (uA) max	At 100K Hz 40(mΩ)max		Size 尺寸	Marking 标识	Sealing 封口
1	45.1	0.0215	7.8	12.7	OK	OK	OK	OK
2	45.5	0.0241	10.6	12.0	OK	OK	OK	OK
3	45.1	0.0163	4.3	9.7	OK	OK	OK	OK
4	45.4	0.0265	3	17.2	OK	OK	OK	OK
5	45.1	0.0224	4.7	11.4	OK	OK	OK	OK
6	45.4	0.0226	13.3	11.1	OK	OK	OK	OK
7	45.5	0.0241	4.9	10.9	OK	OK	OK	OK
8	45.4	0.0216	5.6	10.6	OK	OK	OK	OK
9	44.8	0.0234	91	11.6	OK	OK	OK	OK
10	44.7	0.0224	6.3	10.0	OK	OK	OK	OK
平均值	45.2	0.0225	15.15	11.6				

Decision

判定: PASS

Approver 核准	Designer 编制
伍伟桥	谭艳