

GT-TC198X-HXXX-LX

G-SWITCH Operating Force
 A=180gf
 B=250gf

Switch Height (mm)
 H025=2.5mm
 H027=2.7mm

Switch lifetime (Force)
 L3=300,000 Cycles

G-Switch Specification:

Operating temperature range: -30°C to +85°C
 Rating: 50mA.12V DC
 Insulation resistance: 100MΩ min.100V DC
 Dielectric strength: 250V AC for 1 min
 Contact resistance: 100m Ω max.
 Travel: 0.3±0.1mm

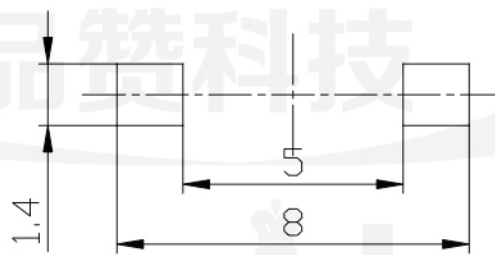
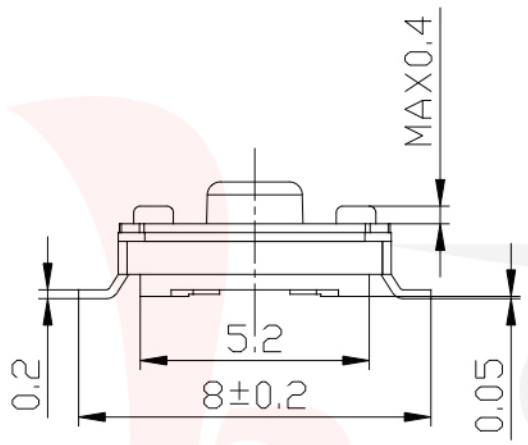

P. C. B LAYOUT

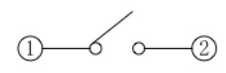
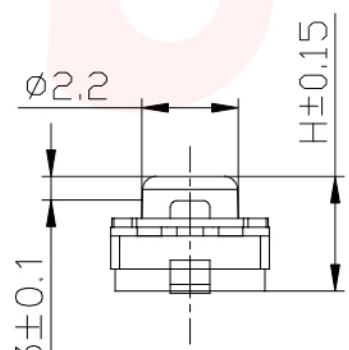

SCHEMATIC



G-Switch Electronic (HongKong) CO.,Ltd.

Unless otherwise specified, Tolerance: X. ±0.30 X.x ±0.20 X.xx ±0.15 X.xxx ±0.10 Angles ±3°	DESIGN 陈锋枫	DATE 2018.10.29	Molde code:		
	CHECKED	DATE	GT-TC198X-HXXX-LX		
	APPROVED	DATE	REV.: X1	SCALE: 4:1	UNIT: mm
	http://www.dg-switch.com TEL: 0769-82388879		SIZE: A4	SHEET: 1/1	