

2305 MOSFET(P-Channel)

V(BR)DSS	RDS(ON)MAX	ID
-12V	45mΩ@-4.5V	-4.1A
	60mΩ@-2.5V	
	90mΩ@-1.8V	

SOT-23 贴片塑封场效应管  
SOT-23 Plastic-Encapsulate MOSFET

特征 Features

- TrenchFET Power MOSFET
- Load Switch for Portable Devices.
- DC/DC Converter.

SOT-23

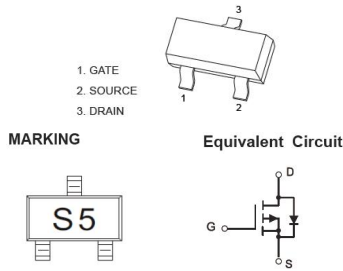

机械数据 Mechanical Data

- 封装: SOT-23 封装 SOT-23 Small Outline Plastic Package.
- 环氧树脂 UL 易燃等级 Epoxy UL: 94V-0.
- 安装位置: 任意 Mounting Position: Any.

极限值和温度特性(TA = 25°C 除非另有规定)

Maximum Ratings & Thermal Characteristics (Ratings at 25°C ambient temperature unless otherwise specified.)

参数 Parameters	符号 Symbol	数值 Value	单位 Unit
Drain-Source Voltage	VDS	-12	V
Gate-Source Voltage	VGS	±8	V
Continuous Drain Current	ID	-4.1	A
Continuous Source-Drain Diode Current	IS	-0.8	
Power Dissipation	PD	350	mW
Junction Temperature	Tj	150	°C
Storage Temperature	Tstg	-50-+150	°C
Thermal Resistance From Junction to Ambient	RθJA	357	°C/W

电特性 (TA = 25°C 除非另有规定)Electrical Characteristics (Ratings at 25°C ambient temperature unless otherwise specified).

参数 Parameter	符号 Symbols	测试条件 Test Condition	界限 Limits			单位 Unit
			Min	Typ	Max	
<b>Static</b>						
Drain-Source Breakdown Voltage	V(BR)DSS	VGS=0V, ID=-250uA	-12			V
Gate-Threshold voltage	VGS(th)	VDS=VGS, ID=-250uA	-0.5		-0.9	V
Gate-body Leakage	IGSS	VDS=0V, VGS=±8V			±100	nA
Zero Gate Voltage Drain current	IDSS	VDS=-8V, VGS=0V			-1	uA
Drain-Source On-Resistance(a)	RDS(ON)	VGS=-4.5V, ID=-3.5A		30	45	mΩ
		VGS=-2.5V, ID=-3.0A		40	60	
		VGS=-1.8V, ID=-2.0A		60	90	
Forward trans conductance(a)	gfs	VDS=-5V, ID=-4.1A	6			S
<b>Dynamic(b,c)</b>						
Input capacitance	Ciss	VDS=-4V, VGS=0V, f=1MHz		740		pF
Output capacitance	Coss			290		
Reverse Transfer capacitance	Crss			190		
Total gate charge	Qg	VDS=-4V, VGS=-4.5V, ID=-4.1A		7.8	15	nC
Gate-source charge	Qgs			4.5	9	
Gate-drain charge	Qgd			1.2		
Gate resistance	Rg	F=1MHz	1.4	7	14	Ω
Turn-on Time	td(on)	VDD=-4V, RL=1.2Ω, VGEN=-4.5V, ID=-3.3A, RG=1Ω		13	20	ns
Rise time	tr			35	53	
Turn-off Time	td(off)			32	48	
Fall time	tf			10	20	
Turn-on Time	td(on)	VDD=-4V, RL=1.2Ω, VGEN=-8V, ID=-3.3A, RG=1Ω		5	10	ns
Rise time	tr			11	17	
Turn-off Time	td(off)			22	33	
Fall time	tf			16	24	
<b>Drain-source body diode characteristics</b>						
Continuous source-drain diode current	IS	Tc=25°C			-1.4	A
Pulse diode forward current (a)	ISM				-10	
Body diode voltage	VSD	IS=-3.3A,			-1.2	V

Notes: a. Pulse Test: Pulse Width  $\leq 300\mu s$ , Duty Cycles  $\leq 2\%$   
 b. Guaranteed by design, not subject to production testing.  
 c. These parameters have no way to verify

**Typical characteristics**

**Output Characteristics**

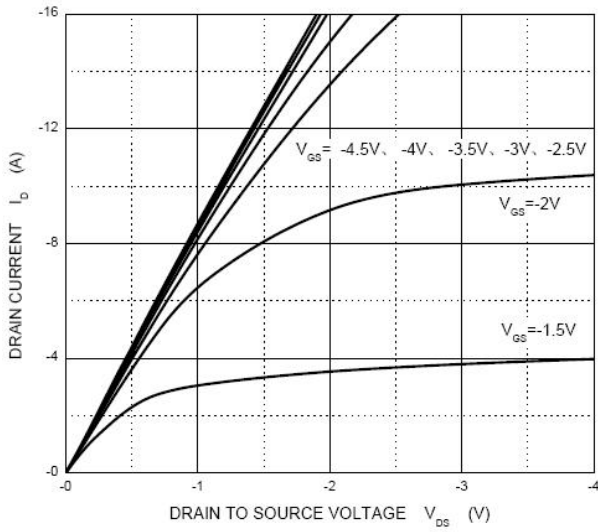

**Transfer Characteristics**

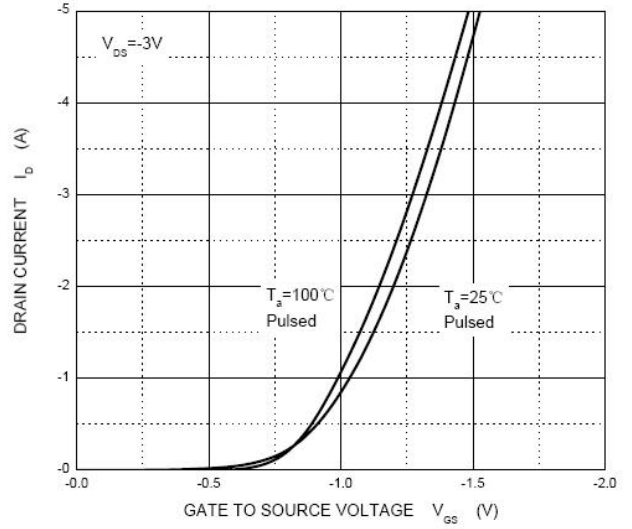

**$R_{DS(ON)}$  —  $I_D$**

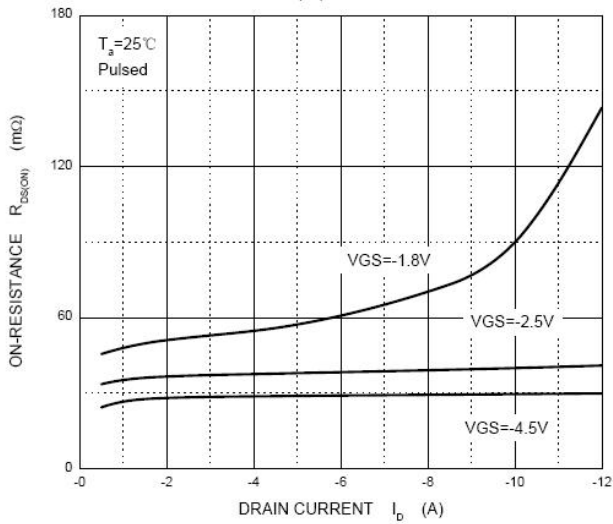

**$R_{DS(ON)}$  —  $V_{GS}$**

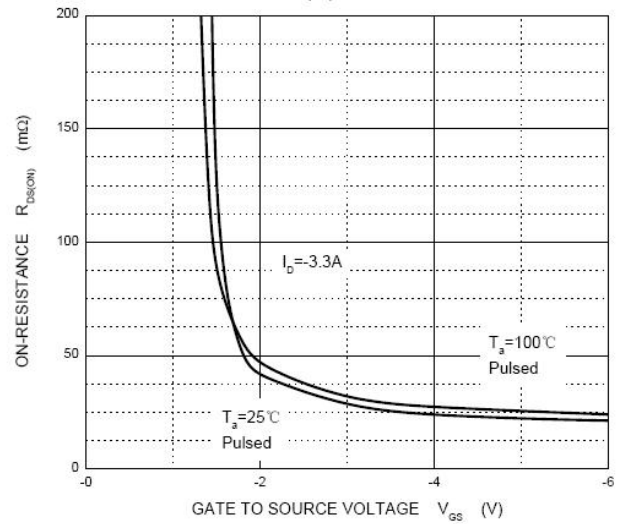

**$I_S$  —  $V_{SD}$**

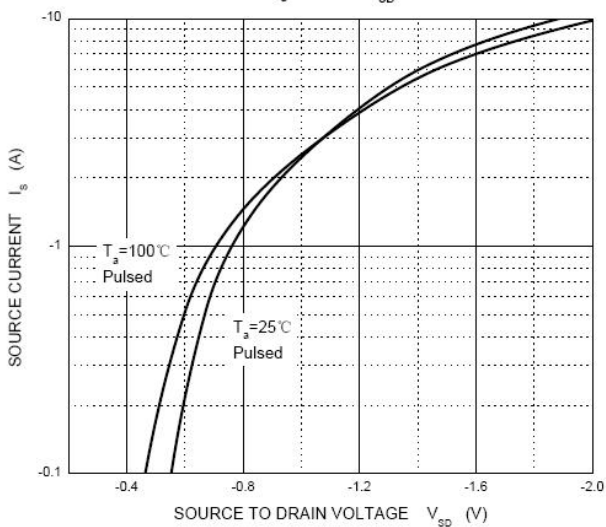

**Threshold Voltage**

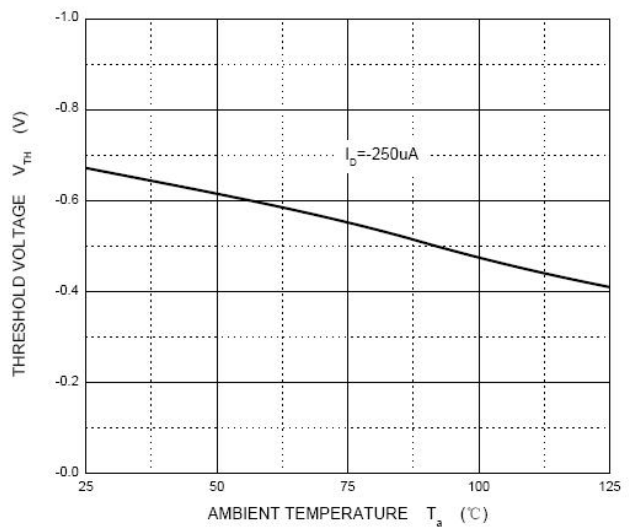

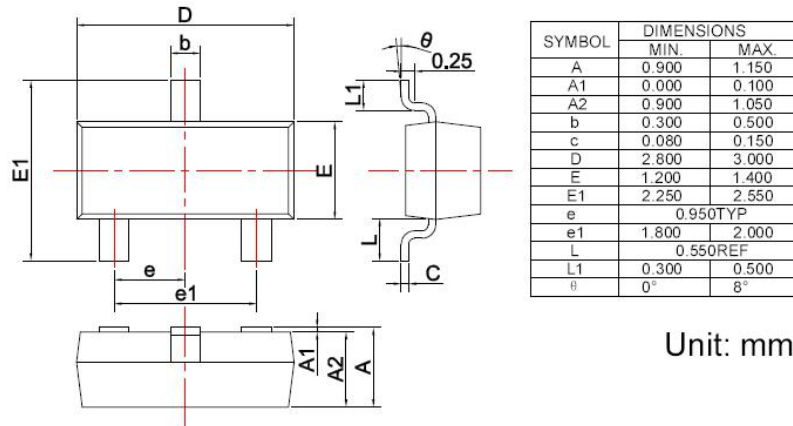
**SOT-23 PACKAGE OUTLINE** Plastic surface mounted package

**焊盘设计参考** Precautions: PCB Design

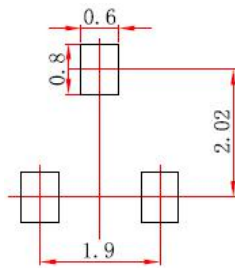
Recommended land dimensions for SOT-23 diode. Electrode patterns for PCBs

**Note:**

1. Controlling dimension: In millimeters.
2. General tolerance:  $\pm 0.05\text{mm}$ .
3. The pad layout is for reference purposes only.