

样品承认书

供应商：深圳市容宝电子有限公司

TEL:0755-27673990 企业 QQ:2851367606

微信/手机：15994804051

下单/询价邮箱 E-mail: rongbaodingdan@163.com

客户名称：

客户物料编号：YXJ 系列

确认签章 (Approved Signatures)

确认签章 (Approved Signatures)					
客户			供应商：		
编写	审核	批准	编写	审核	批准
			臧林	关凌花	林光辉



业务联系人：林光辉 13923782476 日期：

地址：深圳市宝安区松岗街道江边工业区工业二路 11 号创业工业园 A 栋 702-703 室



扫码更方便了实时沟通

YXJ SERIES

105°C Miniaturized, Long Life, Low impedance.

◆FEATURES

- Load Life : 105°C 4000~10000 hours.
- RoHS compliance.

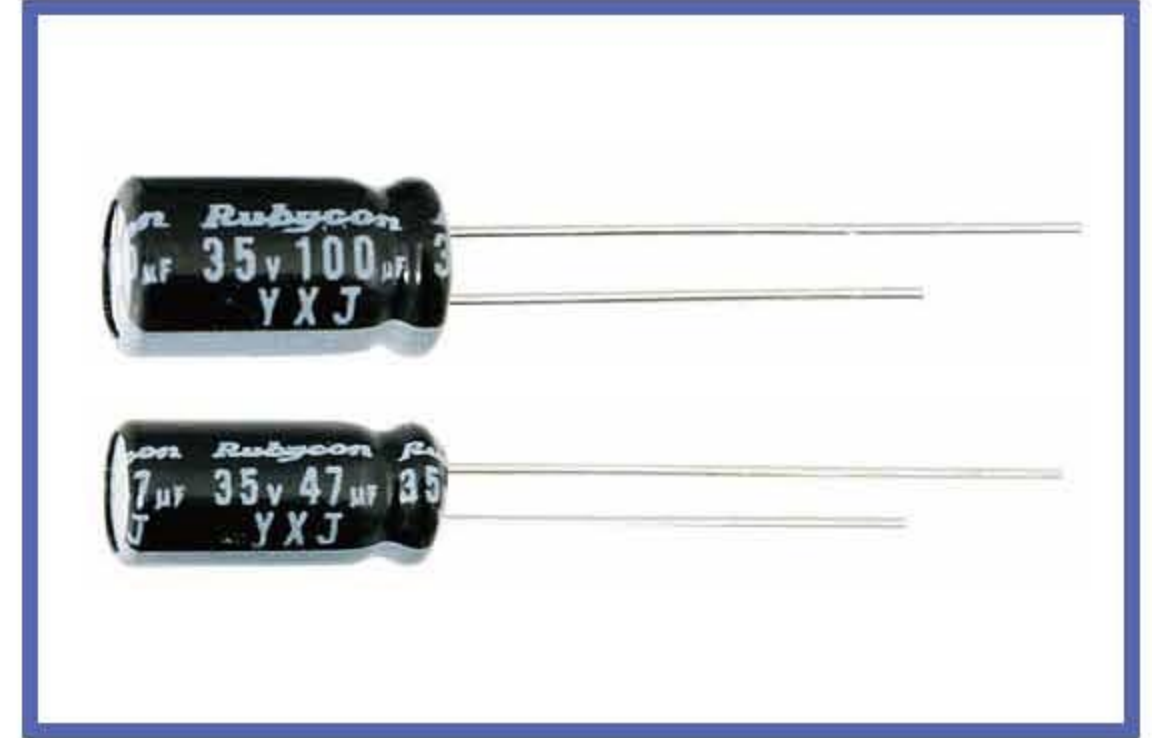

◆SPECIFICATIONS

Items	Characteristics																											
Category Temperature Range	-40~+105°C																											
Rated Voltage Range	6.3~100V.DC																											
Capacitance Tolerance	±20% (20°C, 120Hz)																											
Leakage Current(MAX)	I=0.01CV or 3µA whichever is greater. (After 2 minutes) I=(µA) Leakage Current C=(µF) Rated Capacitance V=(V) Rated Voltage																											
(tanδ) Dissipation Factor(MAX)	<table border="1"> <thead> <tr> <th>Rated Voltage</th> <th>6.3</th> <th>10</th> <th>16</th> <th>25</th> <th>35</th> <th>50</th> <th>63</th> <th>100</th> </tr> </thead> <tbody> <tr> <td>(20°C, 120Hz)</td> <td>0.22</td> <td>0.19</td> <td>0.16</td> <td>0.14</td> <td>0.12</td> <td>0.10</td> <td>0.09</td> <td>0.08</td> </tr> </tbody> </table> <p>When rated capacitance is over 1000µF, tanδ shall be added 0.02 to the listed value with increase of every 1000µF.</p>	Rated Voltage	6.3	10	16	25	35	50	63	100	(20°C, 120Hz)	0.22	0.19	0.16	0.14	0.12	0.10	0.09	0.08									
Rated Voltage	6.3	10	16	25	35	50	63	100																				
(20°C, 120Hz)	0.22	0.19	0.16	0.14	0.12	0.10	0.09	0.08																				
Endurance	<p>After life test with rated ripple current at conditions stated in the table below, the capacitors shall meet the following requirements.</p> <table border="1"> <thead> <tr> <th rowspan="2">Capacitance Change</th> <th rowspan="2">Within ±25% of the initial value.(6.3V:±30%)</th> <th rowspan="2">Case Size</th> <th colspan="2">(hrs) Life Time</th> </tr> <tr> <th>6.3~10WV</th> <th>16~100WV</th> </tr> </thead> <tbody> <tr> <td>Dissipation Factor</td> <td>Not more than 200% of the specified value.</td> <td>φD=5</td> <td>4000</td> <td>5000</td> </tr> <tr> <td>Leakage Current</td> <td>Not more than the specified value.</td> <td>φD=6.3,8</td> <td>6000</td> <td>7000</td> </tr> <tr> <td></td> <td></td> <td>φD≥10</td> <td>8000</td> <td>10000</td> </tr> </tbody> </table>	Capacitance Change	Within ±25% of the initial value.(6.3V:±30%)	Case Size	(hrs) Life Time		6.3~10WV	16~100WV	Dissipation Factor	Not more than 200% of the specified value.	φD=5	4000	5000	Leakage Current	Not more than the specified value.	φD=6.3,8	6000	7000			φD≥10	8000	10000					
Capacitance Change	Within ±25% of the initial value.(6.3V:±30%)				Case Size	(hrs) Life Time																						
		6.3~10WV	16~100WV																									
Dissipation Factor	Not more than 200% of the specified value.	φD=5	4000	5000																								
Leakage Current	Not more than the specified value.	φD=6.3,8	6000	7000																								
		φD≥10	8000	10000																								
Low Temperature Stability Impedance Ratio(MAX)	<table border="1"> <thead> <tr> <th>Rated Voltage</th> <th>6.3</th> <th>10</th> <th>16</th> <th>25</th> <th>35</th> <th>50</th> <th>63</th> <th>100</th> </tr> </thead> <tbody> <tr> <td>Z(-25°C)/Z(20°C)</td> <td>4</td> <td>3</td> <td>2</td> <td>2</td> <td>2</td> <td>2</td> <td>2</td> <td>2</td> </tr> <tr> <td>Z(-40°C)/Z(20°C)</td> <td>8</td> <td>6</td> <td>4</td> <td>3</td> <td>3</td> <td>3</td> <td>3</td> <td>3</td> </tr> </tbody> </table> <p>(120Hz)</p>	Rated Voltage	6.3	10	16	25	35	50	63	100	Z(-25°C)/Z(20°C)	4	3	2	2	2	2	2	2	Z(-40°C)/Z(20°C)	8	6	4	3	3	3	3	3
Rated Voltage	6.3	10	16	25	35	50	63	100																				
Z(-25°C)/Z(20°C)	4	3	2	2	2	2	2	2																				
Z(-40°C)/Z(20°C)	8	6	4	3	3	3	3	3																				

◆MULTIPLIER FOR RIPPLE CURRENT

Frequency Coefficient
(6.3WV~50WV)

Coefficient	(Hz) Frequency	120	1k	10k	100k≤
	Coefficient	0.47~10µF	0.42	0.60	0.80
22~33µF		0.55	0.75	0.90	1.00
47~330µF		0.70	0.85	0.95	1.00
470~1000µF		0.75	0.90	0.98	1.00
2200~15000µF		0.80	0.95	1.00	1.00

(63WV~100WV)

Coefficient	(Hz) Frequency	120	1k	10k	100k≤
Coefficient		0.42	0.60	0.80	1.00

◆DIMENSIONS

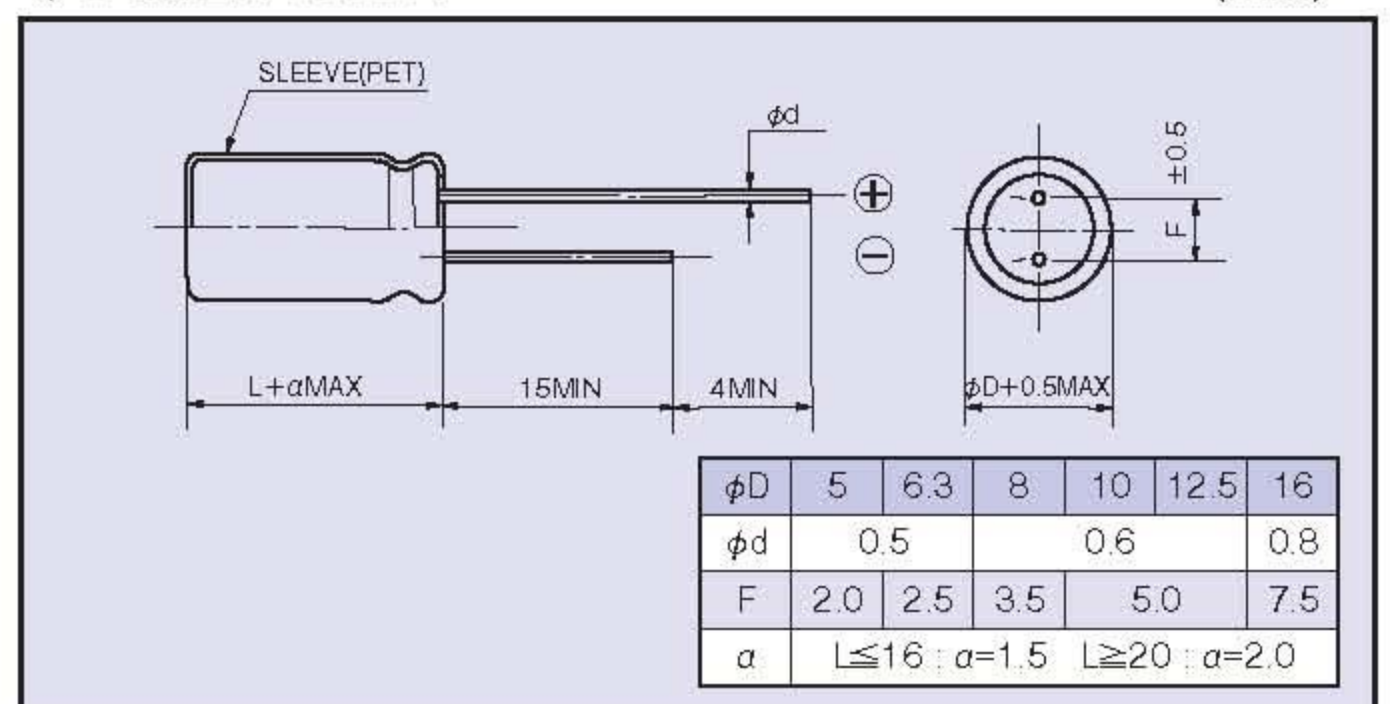

◆OPTION

Option	Code
PET Sleeve	なし Blank

◆PART NUMBER

□□□ YXJ □□□□□ M □□□ □□ DXL
 Rated Voltage Series Rated Capacitance Capacitance Tolerance Option Lead Forming Case Size

◆STANDARD SIZE

Rated Voltage (V·DC)	Rated capacitance (μF)	Size φD×L(mm)	Rated ripple current (mA r.m.s./105°C, 100kHz)	(Ω MAX) Impedance	
				20°C, 100kHz	-10°C, 100kHz
6.3 (0J)	100	5×11	150	0.90	3.6
	220	5×11	250	0.40	1.2
	330	6.3×11	340	0.22	0.87
	470	6.3×11	400	0.22	0.87
	1000	8×11.5	640	0.13	0.52
	2200	10×16	1300	0.062	0.25
	3300	10×20	1400	0.046	0.18
	4700	12.5×25	2230	0.032	0.11
	6800	12.5×25	2230	0.032	0.11
	10000	16×25	2930	0.021	0.060
	15000	16×35.5	3610	0.015	0.044
10 (1A)	100	5×11	150	0.90	3.6
	220	5×11	250	0.40	1.2
	330	6.3×11	400	0.22	0.87
	470	6.3×11	400	0.22	0.87
	1000	10×12.5	865	0.080	0.32
	2200	10×20	1400	0.046	0.18
	3300	12.5×20	1900	0.041	0.14
	4700	12.5×25	2230	0.032	0.11
	6800	16×25	2930	0.021	0.060
10000	16×31.5	3450	0.019	0.056	
16 (1C)	47	5×11	250	0.40	1.2
	100	5×11	250	0.40	1.2
	220	6.3×11	400	0.22	0.87
	330	6.3×11	400	0.22	0.87
	470	8×11.5	640	0.13	0.52
	1000	10×16	1210	0.062	0.25
	2200	12.5×20	1900	0.041	0.14
	3300	12.5×25	2230	0.032	0.11
	4700	16×25	2930	0.021	0.060
6800	16×31.5	3450	0.019	0.056	
25 (1E)	33	5×11	250	0.40	1.2
	47	5×11	250	0.40	1.2
	100	5×11	250	0.40	1.2
	220	6.3×11	400	0.22	0.87
	330	8×11.5	640	0.13	0.52
	470	10×12.5	865	0.080	0.32
	1000	10×20	1400	0.046	0.18
	2200	12.5×25	2230	0.032	0.11
	3300	16×25	2930	0.021	0.060
	4700	16×31.5	3450	0.019	0.056
	35 (1V)	33	5×11	250	0.40
47	5×11	250	0.40	1.2	
100	6.3×11	400	0.22	0.87	
220	8×11.5	640	0.13	0.52	
330	10×12.5	865	0.080	0.32	
470	10×16	1210	0.062	0.25	
1000	12.5×20	1900	0.041	0.14	
2200	16×25	2930	0.021	0.060	
3300	16×31.5	3450	0.019	0.056	

Rated Voltage (V·DC)	Rated capacitance (μF)	Size φD×L(mm)	Rated ripple current (mA r.m.s./105°C, 100kHz)	(Ω MAX) Impedance	
				20°C, 100kHz	-10°C, 100kHz
50 (1H)	0.47	5×11	17	5.5	12.0
	1	5×11	30	4.0	8.0
	2.2	5×11	43	2.5	6.0
	3.3	5×11	53	2.2	5.6
	4.7	5×11	88	1.9	5.0
	10	5×11	100	1.5	4.0
	22	5×11	180	0.70	2.8
	33	5×11	250	0.70	2.8
	47	6.3×11	295	0.30	1.2
	100	8×11.5	555	0.17	0.68
	220	10×16	1050	0.084	0.34
	330	10×20	1220	0.060	0.24
	470	12.5×20	1660	0.045	0.15
	1000	16×25	2730	0.032	0.096
2200	16×35.5	3150	0.019	0.057	
63 (1J)	10	5×11	173	0.88	3.5
	22	5×11	173	0.88	3.5
	33	6.3×11	278	0.35	1.4
	47	6.3×11	278	0.35	1.4
	100	10×12.5	725	0.15	0.60
	220	10×20	1200	0.078	0.31
	330	12.5×20	1570	0.060	0.19
	470	12.5×25	1990	0.043	0.14
1000	16×25	2730	0.032	0.096	
100 (2A)	0.47	5×11	15	6.0	17.0
	1	5×11	20	4.5	15.0
	2.2	5×11	30	3.0	13.0
	3.3	5×11	40	2.7	11.0
	4.7	5×11	65	2.5	10.0
	10	6.3×11	267	0.57	2.3
	22	6.3×11	267	0.57	2.3
	33	8×11.5	462	0.36	1.4
	47	8×16	585	0.25	1.0
	100	10×20	1040	0.12	0.52
	220	12.5×25	1620	0.060	0.23
330	16×25	2210	0.044	0.16	