

CUSTOMER DRAWING

版次 REV.	ECN编号 ECN NUMBER	设变内容 MODIFICATION	日期 DATE	制图 DRAW	核准 APPROVE
A		初版发行	28-JUN-18	DOREN	DDS

NOTES

MATERIAL
 1. HOUSING MATERIAL : GLASS FILLED POLYESTER UL94V-0.
 2. CONTACT MATERIAL : PHOSPHOR BRONZE ϕ 0.46mm.
 3. PLATING : GOLD FLASH PLATING OVER NICKEL.

ELECTRICAL
 1. VOLTAGE RATING : 125 VAC RMS.
 2. CURRENT RATING : 1.5 AMP.
 3. CONTACT RESISTANCE : 40 MILLIOHMS MAX.
 4. INSULATION RESISTANCE : 500 MEGOHMS MIN @ 100V DC .
 5. DIELECTRIC DIELECTRIC RESISTANCE : 500V DC RMS 50Hz. 1MIN.

MECHANICAL
 1. DURRABILITY : 750 CYCLES MIN.
 2. MATING/UNMATING FORCE: 2.04 KG. F MAX.

ENVIRONMENTAL :
 1. STORAGE : -40°C~+85°C.
 2. OPERATION : 0° C TO 70° C.

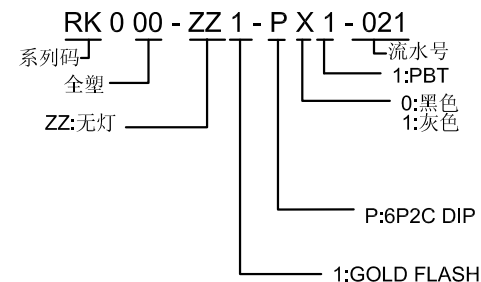
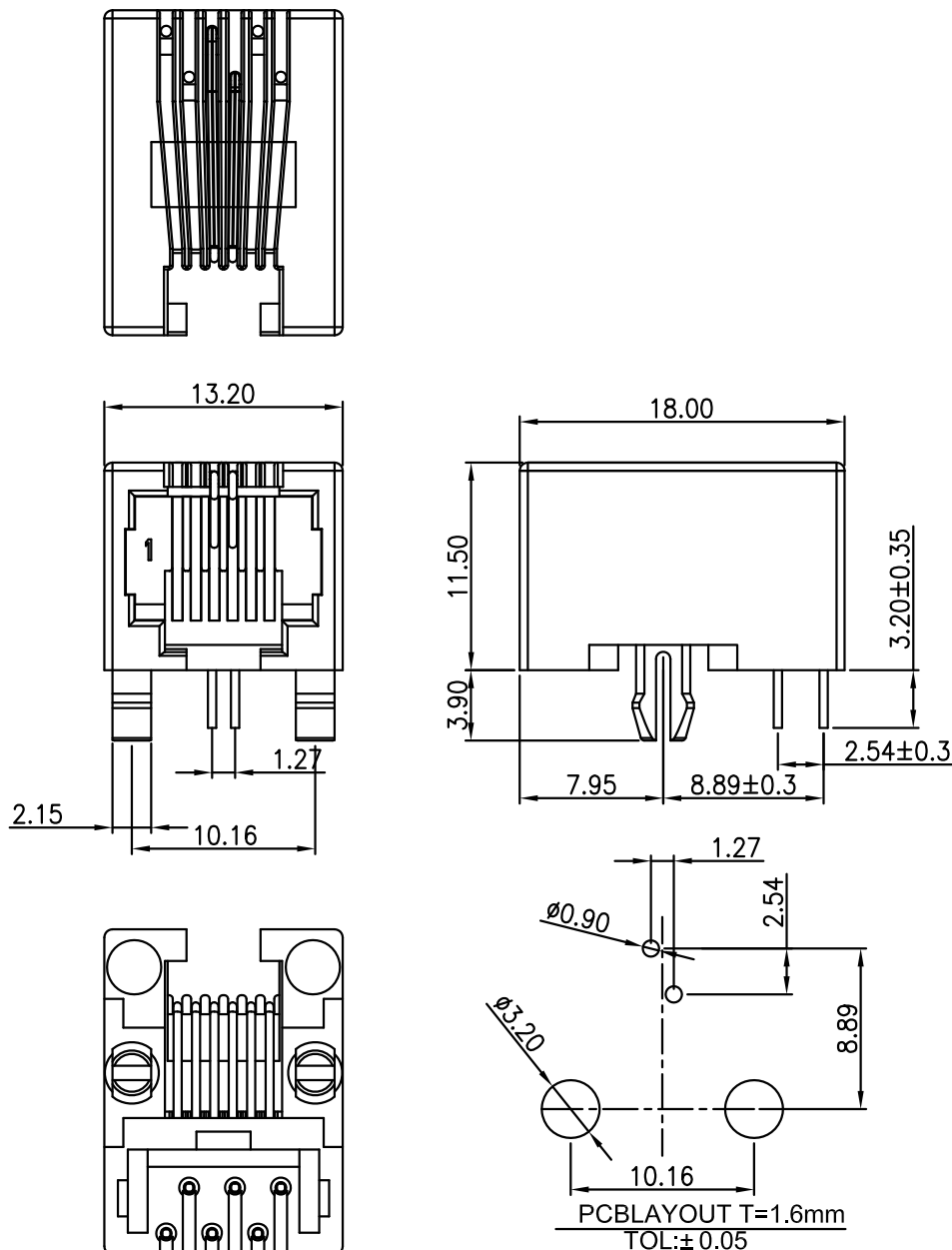

THESE DRAWINGS AND SPECIFICATIONS ARE THE PROPERTY OF GMA AND SHALL BE COPIED OR NOT BE REPRODUCED, CUED IN ANY MANNER WITHOUT THE PRIOR WRITTEN CONSENT OF GMA.	DIMENSION IN mm [Inch]		GMA 东莞市国满电子科技有限公司 Dongguan Guoman Electronic Technology Co., Ltd.		
	TOLERANCE UNLESS OTHERWISE SPECIFIED		料号 FILE NO.		图号 DWG NO.
	.X± 0.35	X° ± 3°	RK000-ZZ1-PX1-021		RK021-P
	.XX± 0.25	.X° ± 2°	名称 TITLE		
.XXX± 0.15	.XX° ± 1°	RJ11 6P2C全塑DIP			
核准 APPROVE	审核 CHECK	制图 DRAW	角法 PROJ.	图纸 SIZE A4	
ZILL	DDS	DOREN	比例 SCALE 1:1	张数 SHEET 1/1	版次 REV A