

**CJAC20N10 N-Channel Power MOSFET**

$V_{(BR)DSS}$	$R_{DS(on)MAX}$	$I_D$
100V	31mΩ@10V	20A
	40mΩ@4.5V	

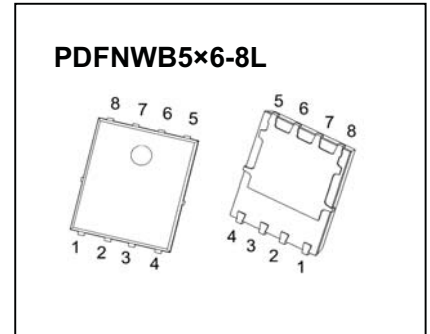

**DESCRIPTION**

This advanced high voltage MOSFET is designed to stand high energy in the avalanche mode and switch efficiently. This new high energy device also offers a drain-to-source diode fast recovery time. Designed for high voltage, high speed switching applications such as power supplies, converters, power motor controls and bridge circuits.

**FEATURES**

- High density cell design for ultra low  $R_{DS(on)}$
- Fully characterized avalanche voltage and current
- Good stability and uniformity with high  $E_{AS}$
- Special process technology for high ESD capability
- Excellent package for good heat dissipation

**APPLICATIONS**

- Hard switched and high frequency circuits
- Uninterruptible power supply
- Power switching application

**MARKING**



CJAC20N10 = Part No.  
 Solid dot=Pin1 indicator  
 XXX= Code

**EQUIVALENT CIRCUIT**

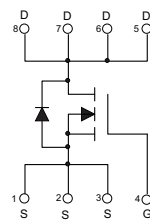

**MAXIMUM RATINGS (  $T_a=25^{\circ}C$  unless otherwise noted )**

Parameter	Symbol	Limit	Unit
Drain-Source Voltage	$V_{DS}$	100	V
Gate-Source Voltage	$V_{GS}$	±20	V
Continuous Drain Current	$I_D$	20	A
Pulsed Drain Current	$I_{DM}$	80	A
Single Pulsed Avalanche Energy	$E_{AS}^{(1)}$	156	mJ
Power Dissipation	$P_D^{(2)}$	2	W
Thermal Resistance from Junction to Ambient	$R_{\theta JA}$	62.5	$^{\circ}C/W$
Junction Temperature	$T_J$	150	$^{\circ}C$
Storage Temperature Range	$T_{stg}$	-55 ~+150	$^{\circ}C$
Lead Temperature for Soldering Purposes(1/8" from case for 10s)	$T_L$	260	$^{\circ}C$

(1). $E_{AS}$  condition:  $V_{DD}=50V, L=0.5mH, R_G=25\Omega$ , Starting  $T_J = 25^{\circ}C$   
 (2).Mounted on a glass epoxy board of 25.4mm x 25.4mm x 0.8mm

# MOSFET ELECTRICAL CHARACTERISTICS

$T_a=25^\circ\text{C}$  unless otherwise specified

## ELECTRICAL CHARACTERISTICS( $T_a=25^\circ\text{C}$ unless otherwise specified)

Parameter	Symbol	Test Condition	Min	Typ	Max	Unit
<b>Off characteristics</b>						
Drain-source breakdown voltage	$V_{(BR)DSS}$	$V_{GS} = 0V, I_D = 250\mu A$	100			V
Zero gate voltage drain current	$I_{DSS}$	$V_{DS} = 100V, V_{GS} = 0V$			1	$\mu A$
Gate-body leakage current	$I_{GSS}$	$V_{DS} = 0V, V_{GS} = \pm 20V$			$\pm 100$	nA
<b>On characteristics (note1)</b>						
Gate-threshold voltage	$V_{GS(th)}$	$V_{DS} = V_{GS}, I_D = 250\mu A$	1.3	2.0	2.5	V
Static drain-source on-state resistance	$R_{DS(on)}$	$V_{GS} = 10V, I_D = 15A$		26	31	$m\Omega$
		$V_{GS} = 4.5V, I_D = 15A$		30	40	$m\Omega$
Forward transconductance	$g_{fs}$	$V_{DS} = 5V, I_D = 10A$		15		S
<b>Dynamic characteristics (note 2)</b>						
Input capacitance	$C_{iss}$	$V_{DS} = 25V, V_{GS} = 0V,$ $f = 1MHz$		2000		pF
Output capacitance	$C_{oss}$			300		
Reverse transfer capacitance	$C_{rss}$			250		
<b>Switching characteristics (note 2)</b>						
Total gate charge	$Q_g$	$V_{DS} = 50V, V_{GS} = 10V,$ $I_D = 10A$		39		nC
Gate-source charge	$Q_{gs}$			8		
Gate-drain charge	$Q_{gd}$			12		
Turn-on delay time	$t_{d(on)}$	$V_{DD} = 30V, V_{GS} = 10V, R_G =$ $3.0\Omega, I_D = 2A, R_L = 5\Omega$		7		ns
Turn-on rise time	$t_r$			7		
Turn-off delay time	$t_{d(off)}$			29		
Turn-off fall time	$t_f$			7		
<b>Drain-Source Diode Characteristics</b>						
Drain-source diode forward voltage(note1)	$V_{SD}$	$V_{GS} = 0V, I_S = 15A$			1.2	V
Continuous drain-source diode forward current	$I_S$				30	A
Pulsed drain-source diode forward current	$I_{SM}$				120	A

Notes:

1. Pulse Test : Pulse Width  $\leq 300\mu s$ , duty cycle  $\leq 2\%$ .
2. Guaranteed by design, not subject to production.

# Typical Characteristics

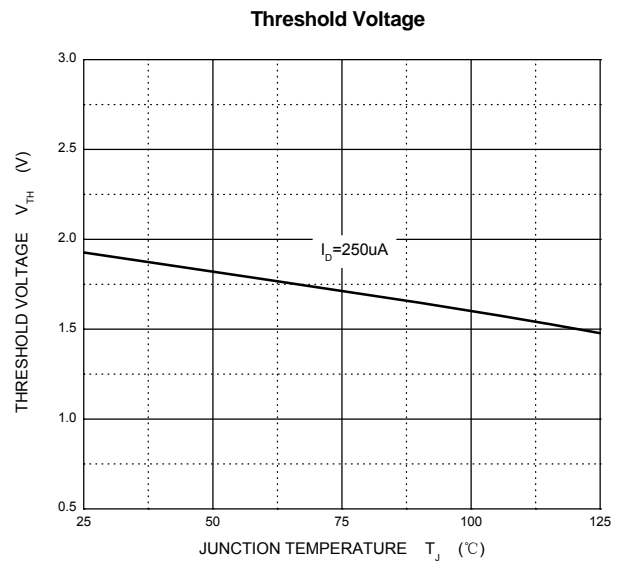
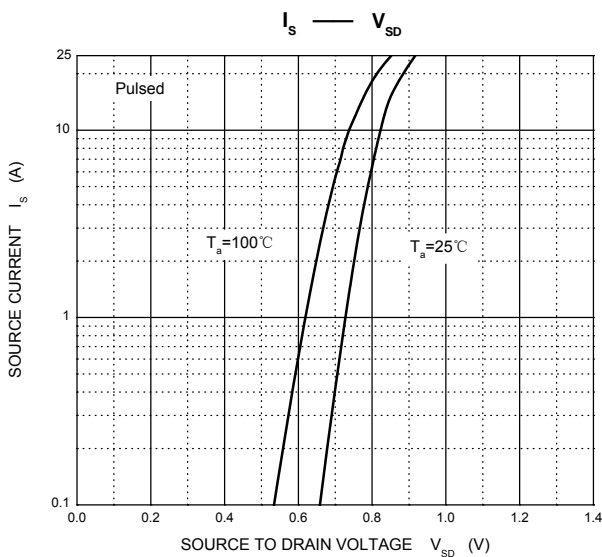
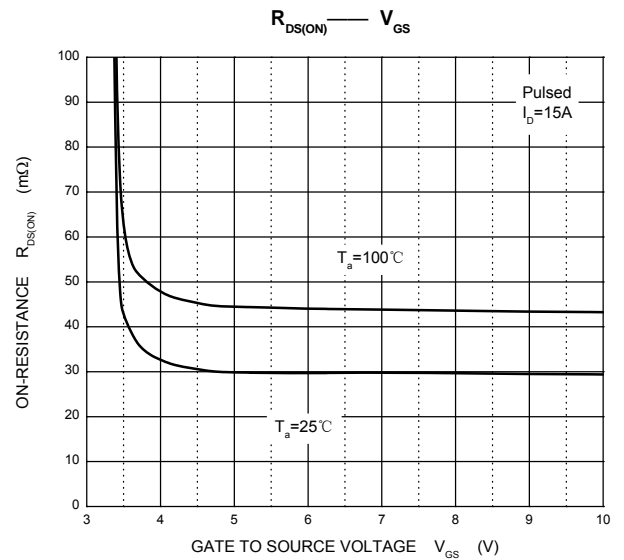
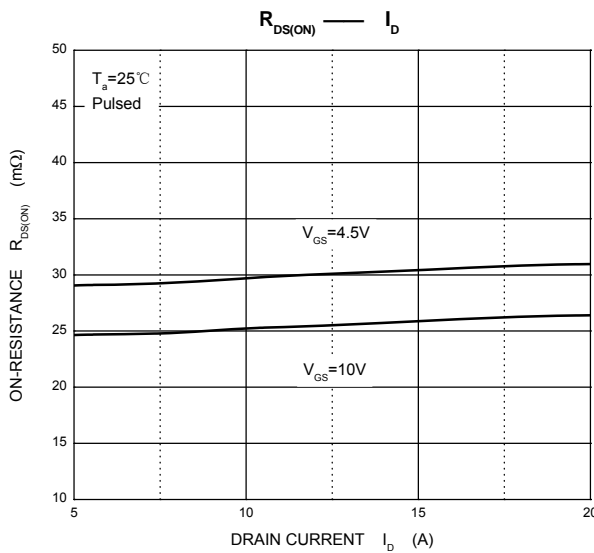
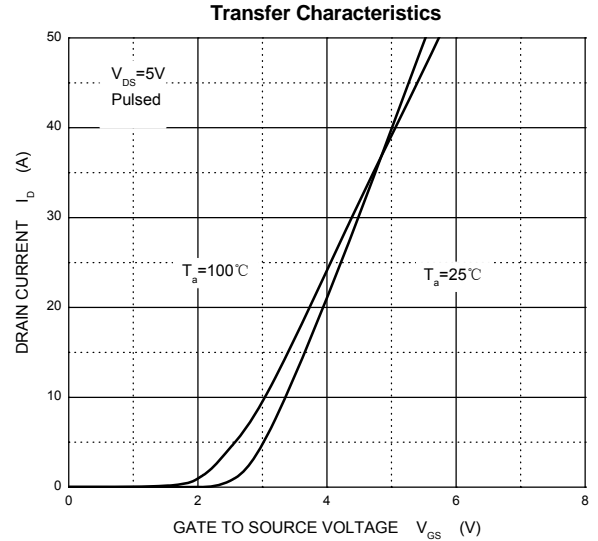
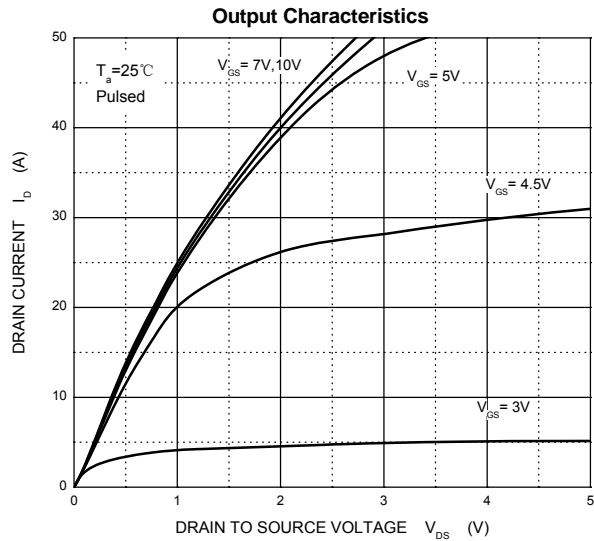

## PDFNWB5x6-8L Package Outline Dimensions

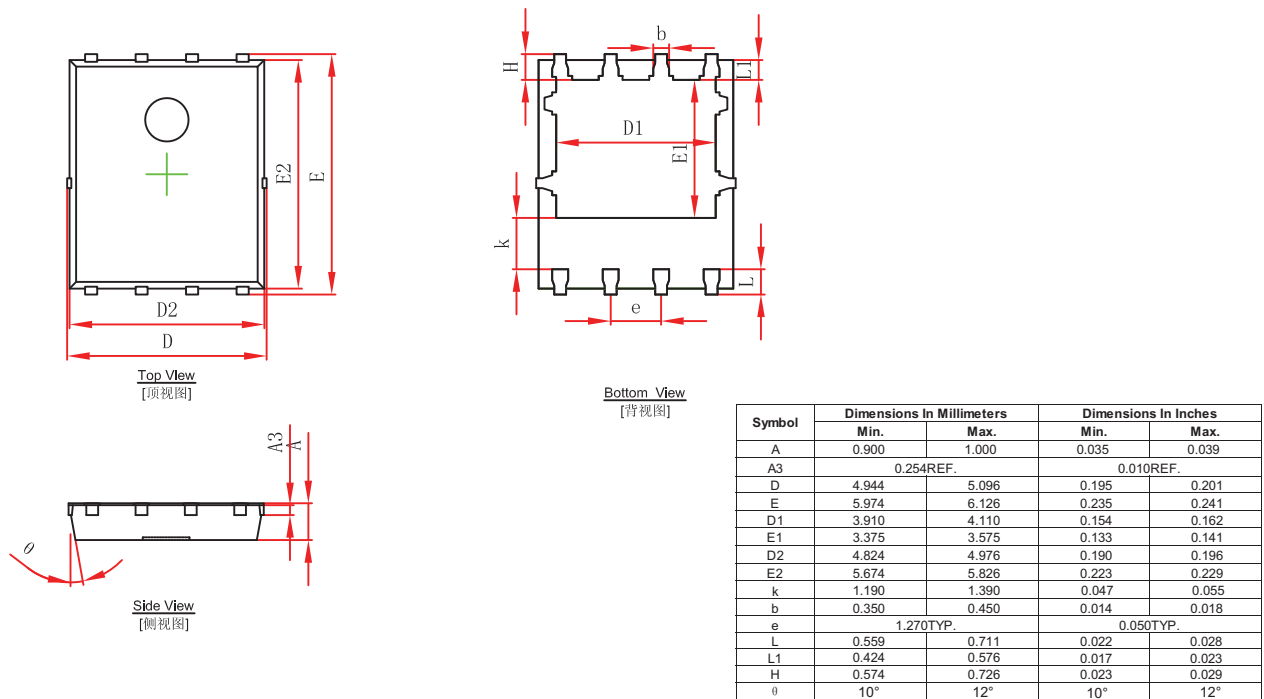

## PDFNWB5x6-8L Suggested Pad Layout

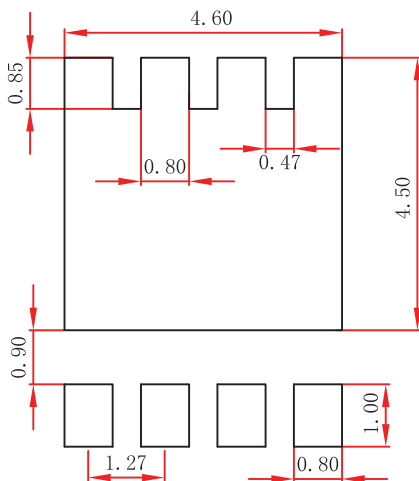

### Note:

1. Controlling dimension: in millimeters.
2. General tolerance:  $\pm 0.05\text{mm}$ .
3. The pad layout is for reference purposes only.

### NOTICE

JSCJ reserves the right to make modifications, enhancements, improvements, corrections or other changes without further notice to any product herein. JSCJ does not assume any liability arising out of the application or use of any product described herein.

# PDFNWB5×6 Tape and Reel

## PDFNWB5×6-8L Embossed Carrier Tape

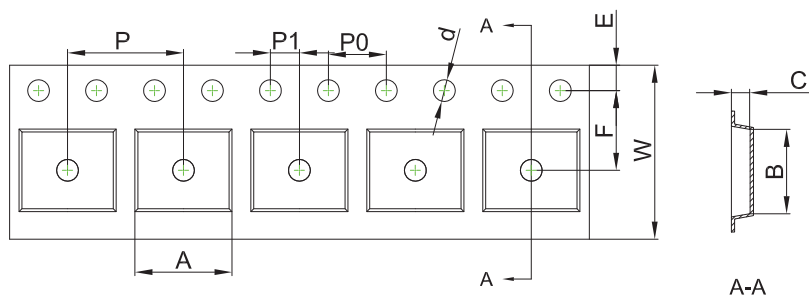

**Packaging Description:**  
**PDFNWB5×6-8L** parts are shipped in tape. The carrier tape is made from a dissipative (carbon filled) polycarbonate resin. The cover tape is a multilayer film (Heat Activated Adhesive in nature) primarily composed of polyester film, adhesive layer, sealant, and anti-static sprayed agent. These reeled parts in standard option are shipped with 5,000 units per 13" or 33.0 cm diameter reel. The reels are clear in color and is made of polystyrene plastic (anti-static coated).

Dimensions are in millimeter

Pkg type	A	B	C	d	E	F	P0	P	P1	W
PDFNWB5×6-8L	6.30	5.30	1.10	Ø1.50	1.75	5.50	4.00	8.00	2.00	12.00

## PDFNWB5×6-8L Tape Leader and Trailer

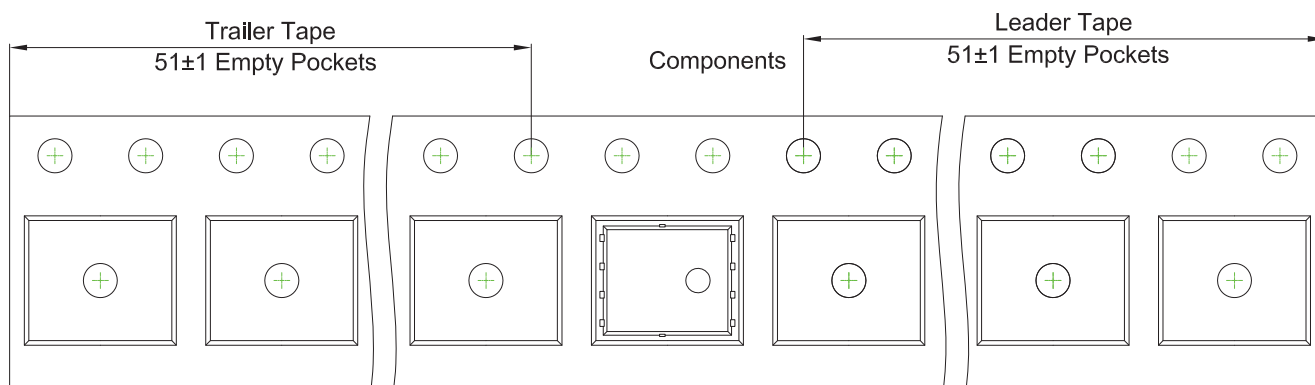

## PDFNWB5×6-8L Reel

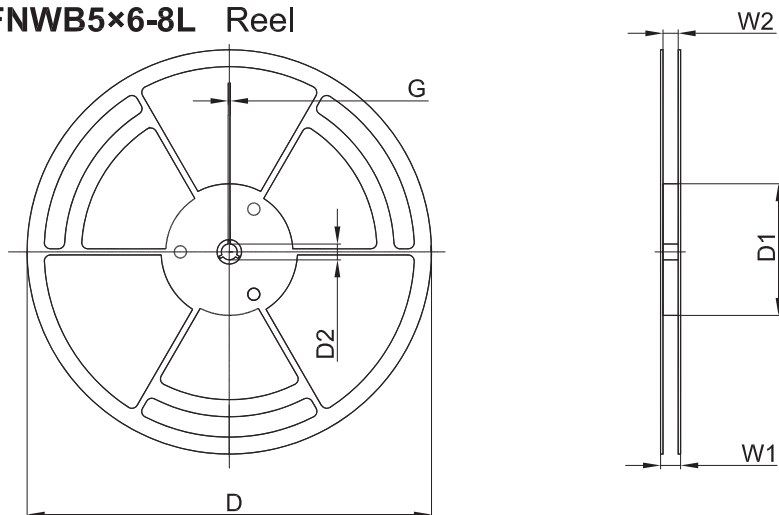

Dimensions are in millimeter

Reel Option	D	D1	D2	G	W1	W2
13" Dia	Ø330.00	100.00	13.00	1.90	17.60	12.40

REEL	Reel Size	Box	Box Size(mm)	Carton	Carton Size(mm)
5,000 pcs	13 inch	5,000 pcs	340×336×29	50,000 pcs	353×346×365