

# SPECIFICATIONS

<b>Customer</b>	
<b>Product Name</b>	<b>Multi-layer Chip Ceramic Inductors</b>
<b>Sunlord Part Number</b>	<b>SDCL0603Q-02B01 Series</b>
<b>Customer Part Number</b>	

New Released,  Revised]

SPEC No.: **SDCL03130000**

Rev.	Effective Date	Changed Contents	Change reasons	Approved By
01	/	New release	/	Hai Guo

**【This SPEC is total 9 pages including specifications and appendix. 】**

**【RoHS Compliant Parts】**

Approved By	Checked By	Issued By

## Shenzhen Sunlord Electronics Co., Ltd.

Address: Sunlord Industrial Park, Dafuyuan Industrial Zone, Baoan, Shenzhen, China 518110  
 Tel: 0086-755-82400574 Fax: 0086-755-82269029 E-Mail: sunlord@sunlordinc.com

**【For Customer approval Only】**

Date: \_\_\_\_\_

Qualification Status:  Full  Restricted  Rejected

Approved By	Verified By	Re-checked By	Checked By

Comments:

\_\_\_\_\_

1. Scope

This specification applies to SDCL0603Q-02B01 series of multi-layer ceramic chip inductors.

2. Product Description and Identification (Part Number)

- 1) Description  
SDCL0603Q-02B01 series of multi-layer ceramic chip inductors.

- 2) Product Identification (Part Number)

SDCL 0603 Q XXX □ ◎ 02 B01  
 ① ② ③ ④ ⑤ ⑥ ⑦ ⑧

①	Type
SDCL	Ceramic Chip Inductor

②	External Dimensions (L X W) (mm)
0603 [0201]	0.6 X 0.3

③	Applications and Characteristics Code
Q	High Q type

④	Nominal Inductance
Example	Nominal Value
3N9	3.9nH
10N	10nH

⑤	Inductance Tolerance
B、C、S	±0.1、±0.2、±0.3nH
G、H、J	±2%、±3%、±5%

⑥	Packing
T	Tape Carrier Package

⑦	Serial Code
02	

⑧	Internal Code
B01	

3. Electrical Characteristics

Please refer to Appendix A (Page 8-9).

- 1) Operating and storage temperature range (individual chip without packing): -55°C~ +125°C,
- 2) Storage temperature range (packaging conditions): -10°C~+40°C and RH 70% (Max.)

4. Shape and Dimensions

- 1) Dimensions and recommended PCB pattern for reflow soldering: See Fig.4-1, Fig.4-2 and Table 4-1.
- 2) Structure: See Fig. 4-3 and Fig. 4-4.

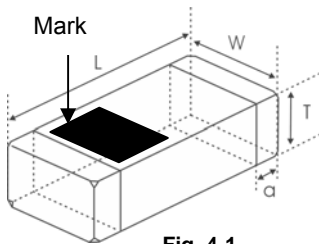

Fig. 4-1

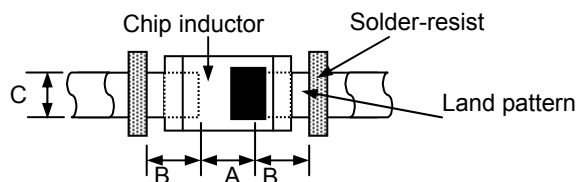

Fig. 4-2

[Table 4-1]

Unit: mm [inch]

Type	L	W	T	a	A	B	C
0603 [0201]	0.6±0.05 [.024±.002]	0.3±0.05 [.012±.002]	0.3±0.05 [.012±.002]	0.12±0.05 [.005±.002]	0.2~0.3	0.25~0.35	0.25~0.35

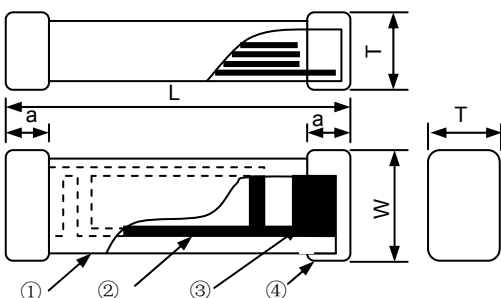

Fig. 4-3

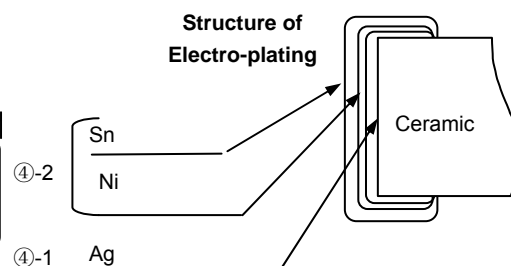

Fig. 4-4

- ① Ceramic for SDCL Series
- ② Internal electrode (Ag)
- ③ Pull out electrode (Ag)
- ④-1 Terminal electrode: Inside (Ag)
- ④-2 Outside (Electro-plating Ni-Sn)

3) Material Information: See **Table 4-2**

[Table 4-2]

Code	Part Name	Material Name
①	Ceramic Body	Ceramic Powder
②	Inner Coils	Silver Paste
③	Pull-out Electrode (Ag)	Silver Paste
④-1	Terminal Electrode: Inside Ag	Termination Silver Composition
④-2	Electro-Plating: Ni/Sn plating	Plating Chemicals

4) Soldering Notice: The surface with the mark should be on the top side when soldering, but it is not necessary to identify the mark's direction towards left or right.

## 5. Test and Measurement Procedures

### 5.1 Test Conditions

Unless otherwise specified, the standard atmospheric conditions for measurement/test as:

- Ambient Temperature:  $20 \pm 15^\circ\text{C}$
- Relative Humidity:  $65 \pm 20\%$
- Air Pressure: 86 KPa to 106 KPa

If any doubt on the results, measurements/tests should be made within the following limits:

- Ambient Temperature:  $20 \pm 2^\circ\text{C}$
- Relative Humidity:  $65 \pm 5\%$
- Air Pressure: 86KPa to 106 KPa

### 5.2 Visual Examination

- Inspection Equipment: 60 X magnifier

### 5.3 Electrical Test

#### 5.3.1 DC Resistance (DCR)

- Refer to **Appendix A**.
- Test equipment (Analyzer): High Accuracy Milliohmmeter-HP4338B or equivalent.

#### 5.3.2 Inductance (L)

- Refer to **Appendix A**.
- Test equipment: High Accuracy RF Impedance /Material Analyzer-E4991A+16197A or equivalent.
- Test signal: -20dBm or 50mV
- Test frequency refers to Appendix A.
- Short bar residual inductance=0.43nH

#### 5.3.3 Q Factor (Q)

- Refer to **Appendix A**.
- Test equipment: High Accuracy RF Impedance /Material Analyzer-E4991A+16197A or equivalent.
- Test signal: -20dBm or 50mV
- Test frequency refers to Appendix A.

#### 5.3.4 Self-Resonant Frequency (SRF)

- Refer to **Appendix A**.
- Test equipment: Agilent 8719ES or equivalent.
- Test signal: -20 dBm or 50 mV

#### 5.3.5 Rated Current

- Refer to **Appendix A**.
- Test equipment (see **Fig. 5.3.5-1**): Electric Power, Electric current meter, Thermometer.
- Measurement method (see **Fig. 5.3.5-1**):
  - Set test current to be 0 mA.
  - Measure initial temperature of chip surface.
  - Gradually increase voltage and measure chip temperature for corresponding current.
- Definition of Rated Current(I<sub>r</sub>): I<sub>r</sub> is direct electric current as chip surface temperature rose just 20°C against chip initial surface temperature(T<sub>a</sub>) (see **Fig. 5.3.5-2**).

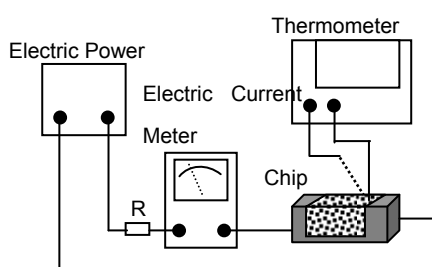

Fig. 5.3.5-1

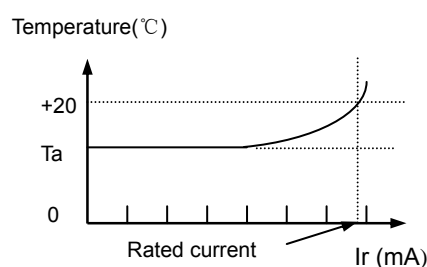
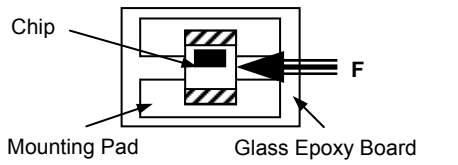
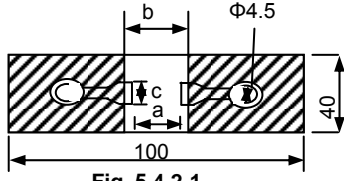
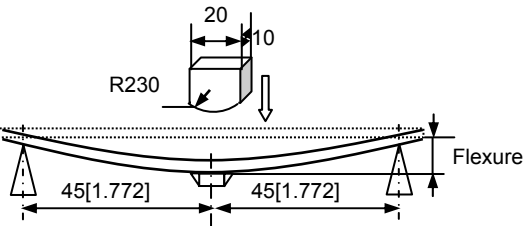
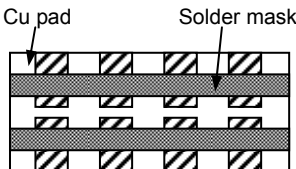
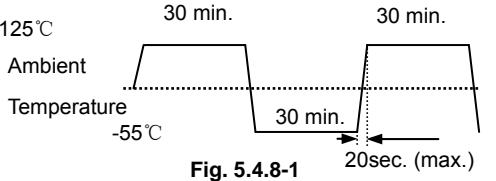

Fig. 5.3.5-2

5.4 Reliability Test

Items	Requirements	Test Methods and Remarks								
5.4.1 Terminal Strength	<p>No removal or split of the termination or other defects shall occur.</p>  <p>Chip Mounting Pad Glass Epoxy Board <b>Fig.5.4.1-1</b></p>	<ol style="list-style-type: none"> <li>Solder the inductor to the testing jig (glass epoxy board shown in <b>Fig. 5.4.1-1</b>) using leadfree solder. Then apply a force in the direction of the arrow.</li> <li>2N force for SDCL0603Q-02B01 series.</li> <li>Keep time: 10±1s</li> <li>Speed: 1.0mm/s.</li> </ol>								
5.4.2 Resistance to Flexure	<p>No visible mechanical damage.</p> <p style="text-align: center;">Unit: mm [inch]</p> <table border="1" data-bbox="327 548 758 638"> <thead> <tr> <th>Type</th> <th>a</th> <th>b</th> <th>c</th> </tr> </thead> <tbody> <tr> <td>0603[0201]</td> <td>0.25</td> <td>0.8</td> <td>0.3</td> </tr> </tbody> </table>  <p><b>Fig. 5.4.2-1</b></p>	Type	a	b	c	0603[0201]	0.25	0.8	0.3	<ol style="list-style-type: none"> <li>Solder the inductor to the test jig (glass epoxy board shown in <b>Fig. 5.4.2-1</b>) Using a leadfree solder. Then apply a force in the direction shown <b>Fig. 5.4.2-2</b>.</li> <li>Flexure: 2mm.</li> <li>Pressurizing Speed: 0.5mm/sec.</li> <li>Keep time: 30 sec.</li> </ol>  <p><b>Fig. 5.4.2-2</b></p>
Type	a	b	c							
0603[0201]	0.25	0.8	0.3							
5.4.3 Vibration	<ol style="list-style-type: none"> <li>No visible mechanical damage.</li> <li>Inductance change: Within ±10%.</li> <li>Q factor change: Within ±20%.</li> </ol>  <p>Cu pad Solder mask Glass Epoxy Board <b>Fig. 5.4.3-1</b></p>	<ol style="list-style-type: none"> <li>Solder the inductor to the testing jig (glass epoxy board shown in <b>Fig. 5.4.3-1</b>) using leadfree solder.</li> <li>The inductor shall be subjected to a simple harmonic motion having total amplitude of 1.5mm, the frequency being varied uniformly between the approximate limits of 10 and 55 Hz.</li> <li>The frequency range from 10 to 55 Hz and return to 10 Hz shall be traversed in approximately 1 minute. This motion shall be applied for a period of 2 hours in each 3 mutually perpendicular directions (total of 6 hours).</li> </ol>								
5.4.4 Dropping	<ol style="list-style-type: none"> <li>No visible mechanical damage.</li> <li>Inductance change: Within ±10%.</li> <li>Q factor change: Within ±20%.</li> </ol>	<p>Drop chip inductor 10 times on a concrete floor from a height of 100 cm.</p>								
5.4.5 Temperature	<p>Inductance change should be within ±10% of initial value measuring at 20°C.</p>	<p>Temperature range: SDCL0603Q-02B01: -55°C to +125°C, Reference temperature: +20°C</p>								
5.4.6 Solderability	<ol style="list-style-type: none"> <li>No visible mechanical damage.</li> <li>Wetting shall exceed 75% coverage.</li> </ol>	<ol style="list-style-type: none"> <li>Solder temperature: 240±2°C</li> <li>Duration: 3 sec.</li> <li>Solder: Sn/3.0Ag/0.5Cu.</li> <li>Flux: 25% Resin and 75% ethanol in weight.</li> </ol>								
5.4.7 Resistance to Soldering Heat	<ol style="list-style-type: none"> <li>No visible mechanical damage.</li> <li>Wetting shall exceed 75% coverage.</li> <li>Inductance change: Within ±10%.</li> <li>Q factor change: Within ±20%.</li> </ol>	<ol style="list-style-type: none"> <li>Solder temperature: 260±3°C</li> <li>Duration: 5 sec.</li> <li>Solder: Sn/3.0Ag/0.5Cu.</li> <li>Flux: 25% Resin and 75% ethanol in weight.</li> <li>The chip shall be stabilized at normal condition for 1~2 hours before measuring.</li> </ol>								

<p>5.4.8 Thermal Shock</p>	<p>① No mechanical damage. ② Inductance change: Within <math>\pm 10\%</math>. ③ Q factor change: Within <math>\pm 20\%</math>.</p>  <p style="text-align: center;"><b>Fig. 5.4.8-1</b></p>	<p>① Temperature, Time: (See <b>Fig. 5.4.8-1</b>) SDCL0603Q-02B01: <math>-55^{\circ}\text{C}</math> for <math>30\pm 3</math> min <math>\rightarrow</math> <math>125^{\circ}\text{C}</math> for <math>30\pm 3</math> min, ② Transforming interval: Max. 20 sec. ③ Tested cycle: 100 cycles. ④ The chip shall be stabilized at normal condition for 1~2 hours before measuring.</p>
<p>5.4.9 Resistance to Low Temperature</p>	<p>① No mechanical damage. ② Inductance change: Within <math>\pm 10\%</math>. ③ Q factor change: Within <math>\pm 20\%</math>.</p>	<p>① Temperature: <math>-55\pm 2^{\circ}\text{C}</math>, ② Duration: <math>1000^{+24}</math> hours. ③ The chip shall be stabilized at normal condition for 1~2 hours before measuring.</p>
<p>5.4.10 Resistance to High Temperature</p>	<p>① No mechanical damage. ② Inductance change: Within <math>\pm 10\%</math>. ③ Q factor change: Within <math>\pm 20\%</math>.</p>	<p>① Temperature: <math>125\pm 2^{\circ}\text{C}</math>, ② Duration: <math>1000^{+24}</math> hours. ③ The chip shall be stabilized at normal condition for 1~2 hours before measuring.</p>
<p>5.4.11 Damp Heat (Steady States)</p>	<p>① No visible mechanical damage. ② Inductance change: Within <math>\pm 10\%</math>. ③ Q factor change: Within <math>\pm 20\%</math>.</p>	<p>① Temperature: <math>60\pm 2^{\circ}\text{C}</math> ② Humidity: 90% to 95% RH. ③ Duration: <math>1000^{+24}</math> hours. ④ The chip shall be stabilized at normal condition for 1~2 hours before measuring.</p>
<p>5.4.12 Loading Under Damp Heat</p>	<p>① No visible mechanical damage. ② Inductance change: Within <math>\pm 10\%</math>. ③ Q factor change: Within <math>\pm 20\%</math>.</p>	<p>① Temperature: <math>60\pm 2^{\circ}\text{C}</math> ② Humidity: 90% to 95% RH. ③ Duration: <math>1000^{+24}</math> hours. ④ Applied current: Rated current. ⑤ The chip shall be stabilized at normal condition for 1~2 hours before measuring.</p>
<p>5.4.13 Loading at High Temperature (Life Test)</p>	<p>① No visible mechanical damage. ② Inductance change: Within <math>\pm 10\%</math>. ③ Q factor change: Within <math>\pm 20\%</math>.</p>	<p>① Temperature: <math>125\pm 2^{\circ}\text{C}</math>, ② Duration: <math>1000^{+24}</math> hours. ③ Applied current: Rated current. ④ The chip shall be stabilized at normal condition for 1~2 hours before measuring.</p>

6. Packaging and Storage

6.1 Packaging

Tape Carrier Packaging:

Packaging code: T

- a. Tape carrier packaging are specified in attached figure **Fig.6.1-1~3**
- b. Tape carrier packaging quantity please see the following table:

Type	0603[0201]
Thickness (mm)	0.3 $\pm$ 0.05
Tape	Paper Tape
Quantity	15K

(1) Taping Drawings (Unit: mm)

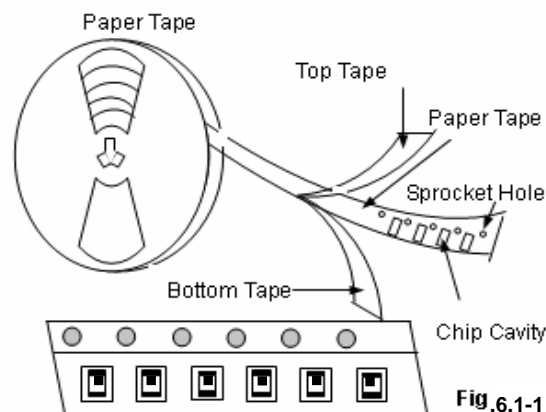

**Remark:** The sprocket holes are to the right as the tape is pulled toward the user.

(2) Taping Dimensions (Unit: mm)

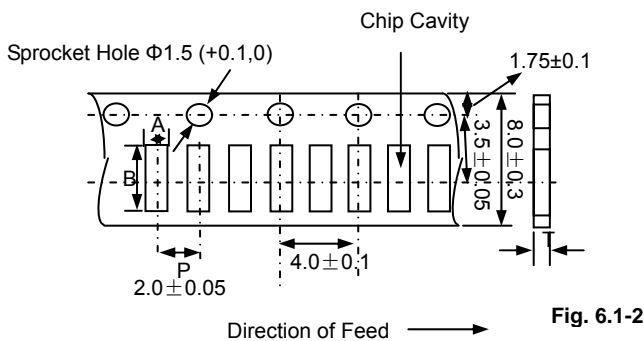

Paper Tape

Type	A	B	P	T max
0603[0201]	$0.4 \pm 0.1$	$0.7 \pm 0.1$	$2.0 \pm 0.05$	0.55

(3) Reel Dimensions (Unit: mm)

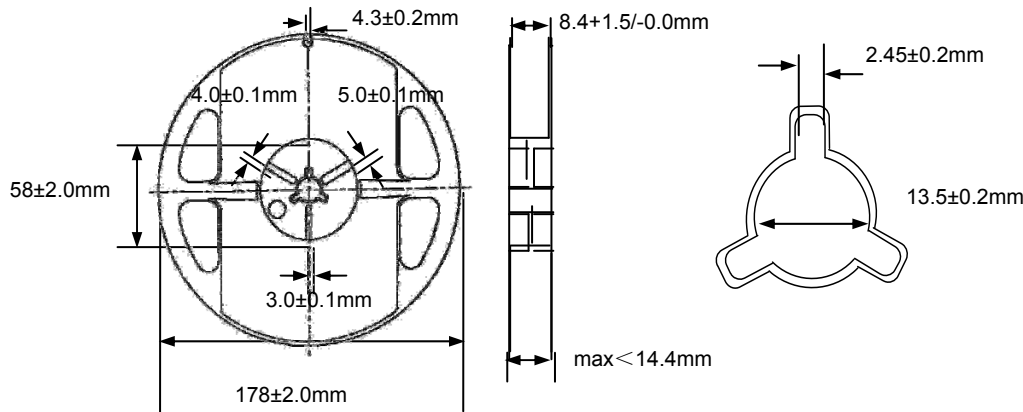

Fig. 6.1-3

6.2 Storage

- The solderability of the external electrode may be deteriorated if packages are stored where they are exposed to high humidity. Package must be stored at  $40^\circ\text{C}$  or less and 70% RH or less.
- The solderability of the external electrode may be deteriorated if packages are stored where they are exposed to dust or harmful gas (e.g. HCl, sulfurous gas of  $\text{H}_2\text{S}$ ).
- Packaging material may be deformed if package are stored where they are exposed to heat of direct sunlight.
- Solderability specified in **Clause 5.4.6** shall be guaranteed for 6 months from the date of delivery on condition that they are stored at the environment specified in **Clause 3**. For those parts, which passed more than 6 months shall be checked solder-ability before use.

7. Recommended Soldering Technologies

7.1 Reflow Profile

- △ Preheat condition:  $150 \sim 200^\circ\text{C} / 60 \sim 120\text{sec}$ .
- △ Allowed time above  $217^\circ\text{C}$ :  $60 \sim 90\text{sec}$ .
- △ Max temp:  $260^\circ\text{C}$
- △ Max time at max temp: 10sec.
- △ Solder paste: Sn/3.0Ag/0.5Cu
- △ Allowed Reflow time: 2x max

[Note: The reflow profile in the above table is only for qualification and is not meant to specify board assembly profiles. Actual board assembly profiles must be based on the customer's specific board design, solder paste and process, and should not exceed the parameters as the Reflow profile shows.]

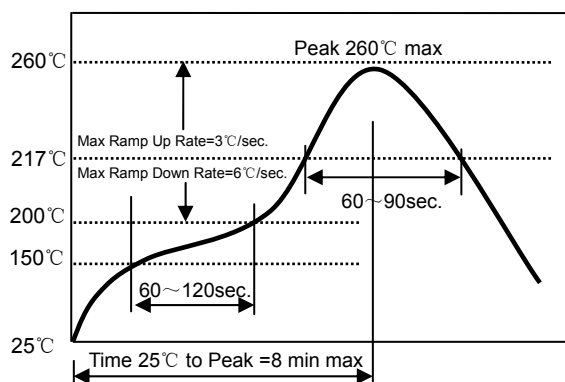

7.2 Iron Soldering Profile

- △ Iron soldering power: Max. 30W
- △ Pre-heating:  $150^\circ\text{C} / 60\text{sec}$ .
- △ Soldering Tip temperature:  $350^\circ\text{C}$  Max.
- △ Soldering time: 3sec. Max.
- △ Solder paste: Sn/3.0Ag/0.5Cu
- △ Max.1 times for iron soldering

[Note: Take care not to apply the tip of the soldering iron to the terminal electrodes.]

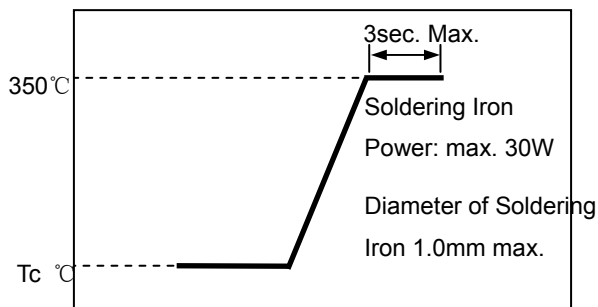

**8. Supplier Information**

a) Supplier:

**Shenzhen Sunlord Electronics Co., Ltd.**

b) Manufacturer:

**Shenzhen Sunlord Electronics Co., Ltd.**

c) Manufacturing Address:

**Sunlord Industrial Park, Dafuyuan Industrial Zone, Guanlan, Shenzhen, China 518110**

Appendix A: Electrical Characteristics (SDCL0603Q-02B01 Series of Inductors)

SDCL0603Q-02B01 Series of Inductor

Part Number	L (nH)	Q Min.	L, Q Test. Freq (MHz)	Q (Typ.) @Freq. (GHz)					S.R.F (MHz) Min	DCR (Ω) Max.	Ir (mA) Max.	Thickness (mm) [inch]
				0.5	0.8	1.8	2.0	2.4				
SDCL0603Q0N6□T02B01	0.6	13	500	>24	>32	>54	>57	>65	10000	0.06	600	0.3±0.05 [.012±.002]
SDCL0603Q0N7□T02B01	0.7	13	500	>24	>32	>54	>57	>65	10000	0.06	550	
SDCL0603Q0N8□T02B01	0.8	13	500	>24	>32	>54	>57	>65	10000	0.07	550	
SDCL0603Q0N9□T02B01	0.9	13	500	>24	>32	>54	>57	>65	10000	0.07	550	
SDCL0603Q1N0□T02B01	1.0	13	500	24	32	54	57	65	10000	0.08	520	
SDCL0603Q1N1□T02B01	1.1	13	500	19	26	45	47	55	10000	0.11	440	
SDCL0603Q1N2□T02B01	1.2	13	500	19	25	43	44	52	10000	0.12	420	
SDCL0603Q1N3□T02B01	1.3	13	500	19	25	40	42	47	10000	0.12	420	
SDCL0603Q1N4□T02B01	1.4	13	500	19	24	39	41	47	10000	0.11	440	
SDCL0603Q1N5□T02B01	1.5	13	500	19	24	39	41	46	10000	0.12	420	
SDCL0603Q1N6□T02B01	1.6	13	500	19	24	39	41	46	10000	0.13	410	
SDCL0603Q1N7□T02B01	1.7	13	500	19	24	39	41	46	10000	0.15	380	
SDCL0603Q1N8□T02B01	1.8	13	500	19	24	39	41	46	10000	0.15	380	
SDCL0603Q1N9□T02B01	1.9	13	500	18	24	38	40	45	10000	0.18	350	
SDCL0603Q2N0□T02B01	2.0	13	500	17	24	38	39	44	10000	0.23	300	
SDCL0603Q2N1□T02B01	2.1	13	500	17	24	37	39	44	10000	0.24	300	
SDCL0603Q2N2□T02B01	2.2	13	500	17	24	38	40	43	10000	0.25	290	
SDCL0603Q2N3□T02B01	2.3	13	500	17	24	37	39	43	10000	0.20	330	
SDCL0603Q2N4□T02B01	2.4	13	500	17	23	36	38	42	10000	0.22	310	
SDCL0603Q2N5□T02B01	2.5	13	500	17	23	35	36	40	9600	0.20	330	
SDCL0603Q2N6□T02B01	2.6	13	500	17	22	34	35	39	9400	0.20	330	
SDCL0603Q2N7□T02B01	2.7	13	500	17	22	34	35	39	9200	0.22	310	
SDCL0603Q2N8□T02B01	2.8	13	500	17	22	34	35	39	8900	0.24	300	
SDCL0603Q2N9□T02B01	2.9	13	500	17	22	34	35	39	8800	0.26	280	
SDCL0603Q3N0□T02B01	3.0	13	500	17	22	34	35	39	8600	0.26	280	
SDCL0603Q3N1□T02B01	3.1	13	500	17	22	34	35	39	8500	0.28	270	
SDCL0603Q3N2□T02B01	3.2	13	500	17	22	33	35	39	8200	0.28	270	
SDCL0603Q3N3□T02B01	3.3	13	500	18	23	34	36	40	8100	0.30	270	
SDCL0603Q3N4□T02B01	3.4	13	500	17	23	33	35	39	8000	0.30	270	
SDCL0603Q3N5□T02B01	3.5	13	500	17	23	33	35	39	7900	0.34	250	
SDCL0603Q3N6□T02B01	3.6	13	500	16	23	33	35	39	7700	0.38	240	
SDCL0603Q3N7□T02B01	3.7	13	500	16	23	33	35	38	7600	0.40	230	
SDCL0603Q3N8□T02B01	3.8	13	500	16	22	33	35	38	7500	0.42	230	
SDCL0603Q3N9□T02B01	3.9	13	500	16	22	33	35	38	7400	0.42	230	
SDCL0603Q4N3□T02B01	4.3	13	500	16	21	32	34	37	6800	0.44	220	
SDCL0603Q4N7□T02B01	4.7	13	500	16	22	33	35	38	6200	0.45	220	
SDCL0603Q5N1□T02B01	5.1	13	500	17	22	34	36	38	5900	0.46	210	
SDCL0603Q5N6□T02B01	5.6	13	500	16	21	33	34	37	5500	0.46	210	
SDCL0603Q6N2□T02B01	6.2	13	500	18	23	34	35	37	5100	0.48	210	
SDCL0603Q6N8□T02B01	6.8	13	500	17	22	32	33	35	5500	0.50	200	
SDCL0603Q7N5□T02B01	7.5	13	500	16	21	31	33	34	4700	0.50	200	
SDCL0603Q8N2□T02B01	8.2	13	500	16	21	31	32	34	4300	0.56	190	
SDCL0603Q9N1□T02B01	9.1	13	500	16	20	30	31	32	4100	0.72	170	
SDCL0603Q10N□T02B01	10	13	500	16	20	28	29	31	3800	0.80	160	
SDCL0603Q12N□T02B01	12	13	500	16	20	27	28	28	3400	0.80	160	
SDCL0603Q15N□T02B01	15	13	500	15	19	24	24	23	2600	0.85	160	
SDCL0603Q18N□T02B01	18	13	500	15	19	23	24	22	2300	1.00	140	
SDCL0603Q22N□T02B01	22	13	500	15	19	22	23	20	1900	1.20	130	
SDCL0603Q27N□T02B01	27	13	500	15	19	15	13	8	1800	1.60	120	
SDCL0603Q33N□T02B01	33	11	300	14	15	8	5	-	1800	2.20	110	



SDCL0603Q39N□T02B01	39	11	300	14	15	6	-	-	1600	2.30	100
SDCL0603Q47N□T02B01	47	11	300	14	15	-	-	-	1500	2.60	100
SDCL0603Q56N□T02B01	56	11	300	13	13	-	-	-	1400	2.80	80
SDCL0603Q68N□T02B01	68	11	300	13	11	-	-	-	1200	3.20	80
SDCL0603Q82N□T02B01	82	10	300	12	10	-	-	-	1100	3.80	70
SDCL0603QR10□T02B01	100	10	300	12	10	-	-	-	1000	4.00	60
SDCL0603QR12□T02B01	120	9	300	12	8	-	-	-	1000	5.00	50

Note: □: Please specify the inductance tolerance. For  $L \leq 6.2\text{nH}$ , choose  $B = \pm 0.1\text{nH}$ ,  $C = \pm 0.2\text{nH}$  or  $S = \pm 0.3\text{nH}$ ; For  $L > 6.2\text{nH}$ , choose,  $H = \pm 3\%$ ,  $J = \pm 5\%$  or  $K = \pm 10\%$