

SLF3101/SLP3101

430V N-Channel MOSFET

General Description

This Power MOSFET is produced using Maple semi's advanced trench MOSFET technology. This advanced technology has been especially tailored to minimize on-state resistance, provide superior switching performance, and withstand high energy pulse in the avalanche and commutation mode. These devices are well suited for high efficiency switched mode power supplies, active power factor correction based on half bridge topology.

Features

- 11A, 430V, $R_{DS(on)typ.} = 0.55\Omega @ V_{GS} = 10V$
- Low gate charge (typical 23nC)
- High ruggedness
- Fast switching
- 100% avalanche tested
- Improved dv/dt capability

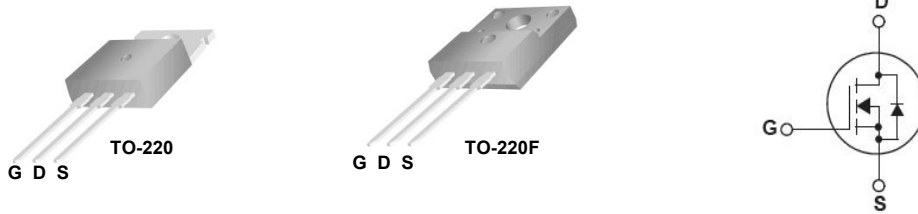

Absolute Maximum Ratings $T_C = 25^\circ\text{C}$ unless otherwise noted

| Symbol | Parameter | SLP3101/SLF3101 | Units |
|----------------|---|-----------------|------------------|
| V_{DSS} | Drain-Source Voltage | 430 | V |
| I_D | Drain Current - Continuous ($T_C = 25^\circ\text{C}$) | 11 | A |
| I_{DM} | Drain Current - Pulsed (Note 1) | 22 | A |
| V_{GSS} | Gate-Source Voltage | ± 30 | V |
| EAS | Single Pulsed Avalanche Energy (Note 2) | 437 | mJ |
| I_{AR} | Avalanche Current (Note 1) | 5.4 | A |
| E_{AR} | Repetitive Avalanche Energy (Note 1) | 19.36 | mJ |
| dv/dt | Peak Diode Recovery dv/dt (Note 3) | 2.8 | V/ns |
| P_D | Power Dissipation ($T_C = 25^\circ\text{C}$) | 35 | W |
| T_J, T_{STG} | Operating and Storage Temperature Range | -55 to +150 | $^\circ\text{C}$ |
| T_L | Maximum lead temperature for soldering purposes, 1/8" from case for 5 seconds | 300 | $^\circ\text{C}$ |
| $V_{ESD(G-S)}$ | Gate Source ESD (HBM - C = 100pF, R = 1.5K Ω) | 2500 | V |

* Drain current limited by maximum junction temperature.

Thermal Characteristics

| Symbol | Parameter | SLP3101/SLF3101 | Units |
|-----------------|---|-----------------|--------------------|
| $R_{\theta JC}$ | Thermal Resistance, Junction-to-Case | 3.86 | $^\circ\text{C/W}$ |
| $R_{\theta JS}$ | Thermal Resistance, Case-to-Sink Typ. | 0.5 | $^\circ\text{C/W}$ |
| $R_{\theta JA}$ | Thermal Resistance, Junction-to-Ambient | 62.5 | $^\circ\text{C/W}$ |

Electrical Characteristics $T_C = 25^\circ\text{C}$ unless otherwise noted

| Symbol | Parameter | Test Conditions | Min | Typ | Max | Units |
|--------|-----------|-----------------|-----|-----|-----|-------|
|--------|-----------|-----------------|-----|-----|-----|-------|

Off Characteristics

| | | | | | | |
|--------------------------------|---|---|-----|------|------|---------------------------|
| BV_{DSS} | Drain-Source Breakdown Voltage | $V_{GS} = 0\text{ V}, I_D = 250\text{ }\mu\text{A}$ | 430 | -- | -- | V |
| $\Delta BV_{DSS} / \Delta T_J$ | Breakdown Voltage Temperature Coefficient | $I_D = 250\text{ }\mu\text{A}$, Referenced to 25°C | -- | 0.40 | -- | $\text{V}/^\circ\text{C}$ |
| I_{DSS} | Zero Gate Voltage Drain Current | $V_{DS} = 400\text{ V}, V_{GS} = 0\text{ V}$ | -- | -- | 10 | μA |
| I_{GSSF} | Gate-Body Leakage Current, Forward | $V_{GS} = 30\text{ V}, V_{DS} = 0\text{ V}$ | -- | -- | 100 | nA |
| I_{GSSR} | Gate-Body Leakage Current, Reverse | $V_{GS} = -30\text{ V}, V_{DS} = 0\text{ V}$ | -- | -- | -100 | nA |

On Characteristics

| | | | | | | |
|--------------|-----------------------------------|---|-----|----|-----|------------|
| $V_{GS(th)}$ | Gate Threshold Voltage | $V_{DS} = V_{GS}, I_D = 250\text{ }\mu\text{A}$ | 2.0 | -- | 4.0 | V |
| $R_{DS(on)}$ | Static Drain-Source On-Resistance | $V_{GS} = 10\text{ V}, I_D = 5.5\text{ A}$ | -- | -- | 550 | m Ω |

Dynamic Characteristics

| | | | | | | |
|------------|------------------------------|--|----|-----|----|----|
| C_{iss} | Input Capacitance | $V_{DS} = 25\text{ V}, V_{GS} = 0\text{ V},$ $f = 1.0\text{ MHz}$ | -- | 940 | -- | pF |
| C_{oss} | Output Capacitance | | -- | 125 | -- | pF |
| C_{riss} | Reverse Transfer Capacitance | | -- | 9.5 | -- | pF |

Switching Characteristics

| | | | | | | |
|--------------|---------------------|--|----|-----|----|----|
| $t_{d(on)}$ | Turn-On Delay Time | $V_{DD} = 200\text{ V}, I_D = 11\text{ A},$ $R_G = 25\Omega$ (Note 4, 5) | -- | 19 | -- | ns |
| t_r | Turn-On Rise Time | | -- | 70 | -- | ns |
| $t_{d(off)}$ | Turn-Off Delay Time | | -- | 70 | -- | ns |
| t_f | Turn-Off Fall Time | | -- | 27 | -- | ns |
| Q_g | Total Gate Charge | $V_{DS} = 320\text{ V}, I_D = 11\text{ A}, I_G = 1\text{ mA}$ $V_{GS} = 10\text{ V}$ (Note 4, 5) | -- | 23 | -- | nC |
| Q_{gs} | Gate-Source Charge | | -- | 5.4 | -- | nC |
| Q_{gd} | Gate-Drain Charge | | -- | 5 | -- | nC |

Drain-Source Diode Characteristics and Maximum Ratings

| | | | | | | |
|----------|---|---|----|-----|-----|---------------|
| I_S | Maximum Continuous Drain-Source Diode Forward Current | -- | -- | 11 | A | |
| I_{SM} | Maximum Pulsed Drain-Source Diode Forward Current | -- | -- | 22 | A | |
| V_{SD} | Drain-Source Diode Forward Voltage | $V_{GS} = 0\text{ V}, I_S = 11\text{ A}$ | -- | -- | 1.4 | V |
| t_{rr} | Reverse Recovery Time | $V_{GS} = 0\text{ V}, I_S = 11\text{ A},$ | -- | 410 | -- | ns |
| Q_{rr} | Reverse Recovery Charge | $di_F / dt = 100\text{ A}/\mu\text{s}$ (Note 4) | -- | 7 | -- | μC |

Notes:

1. Repetitive Rating : Pulse width limited by maximum junction temperature
2. $L = 30\text{ mH}, I_{AS} = 5.4\text{ A}, V_{DD} = 50\text{ V}, R_G = 25\Omega$, Starting $T_J = 25^\circ\text{C}$
3. $I_{SD} \leq 11\text{ A}, di/dt \leq 100\text{ A}/\mu\text{s}, V_{DD} \leq BV_{DSS}$, Starting $T_J = 25^\circ\text{C}$
4. Pulse Test : Pulse width $\leq 300\mu\text{s}$, Duty cycle $\leq 2\%$
5. Essentially independent of operating temperature

Typical Characteristics

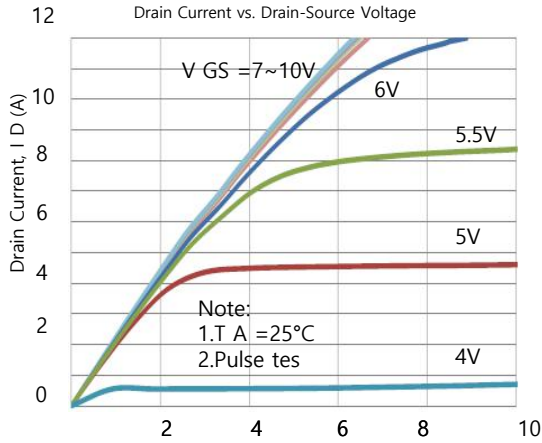

Figure 1. Drain-Source Voltage, V_{DS} (V)

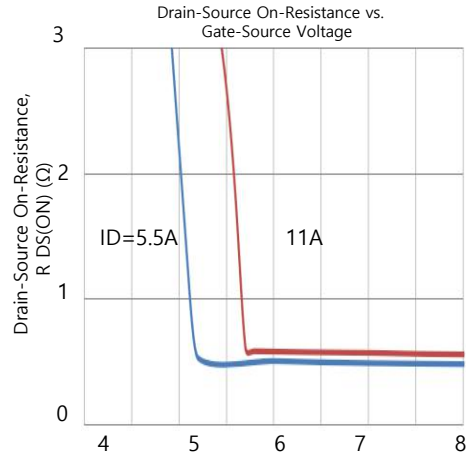

Figure 2. Gate-Source Voltage, V_{GS} (V)

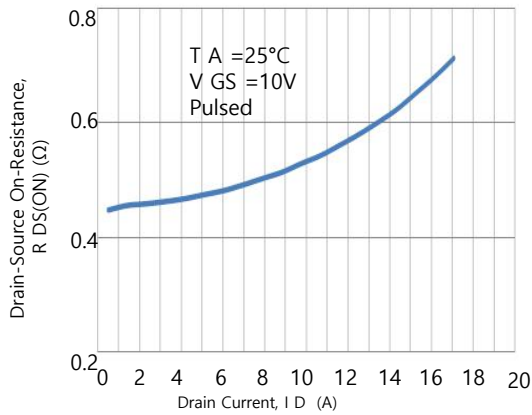

Figure 3. Drain-Source On-Resistance vs. Drain Current

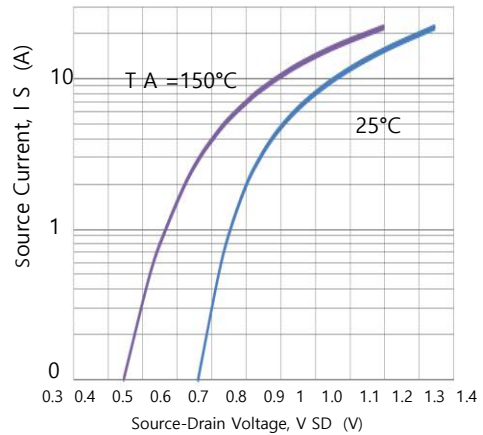

Figure 4. Source Current vs. Source-Drain Voltage

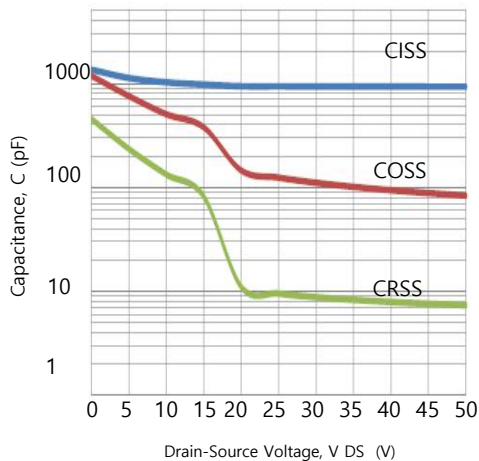

Figure 5. Capacitance Characteristics

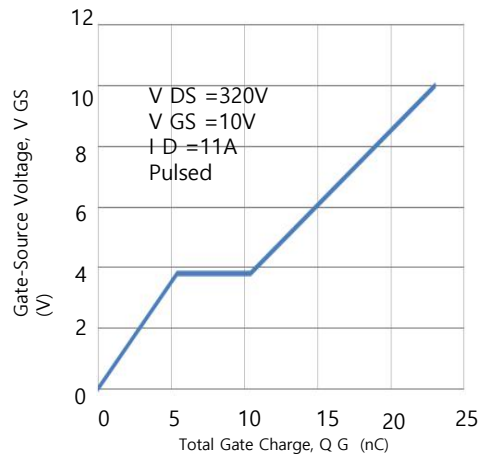

Figure 6. Gate Charge Characteristics

Typical Characteristics (Continued)

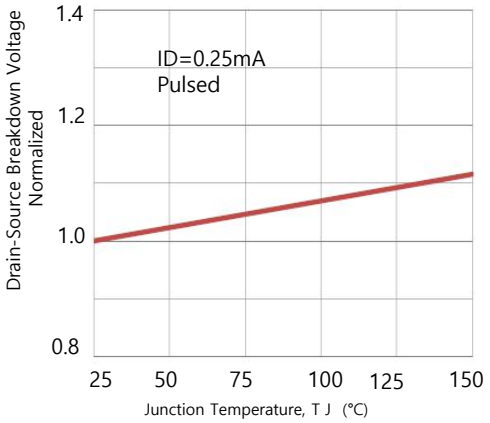

Figure 7. Breakdown Voltage Variation vs Temperature

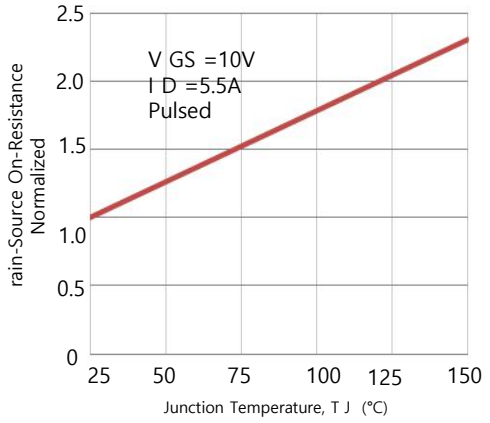

Figure 8. On-Resistance Variation vs Temperature

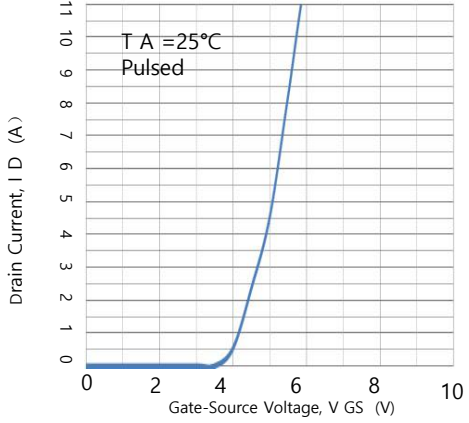

Figure 9 Drain Current vs. Gate-Source Voltage

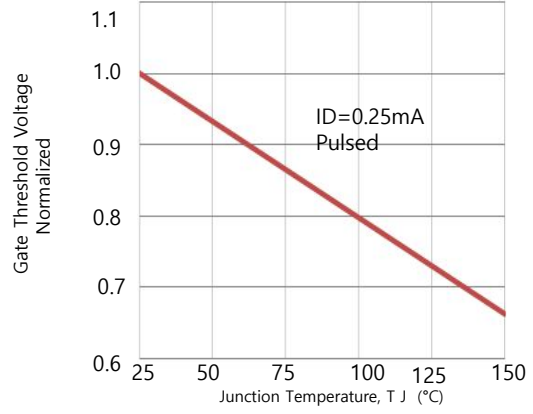

Figure 10 Gate Threshold Voltage vs. Junction Temperature

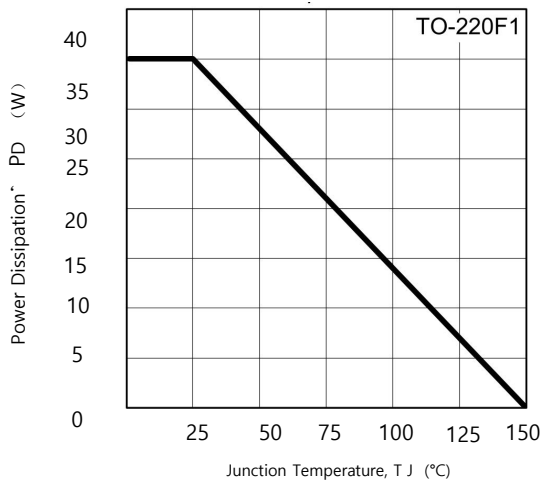

Figure 11. Power Dissipation vs. Junction Temperature

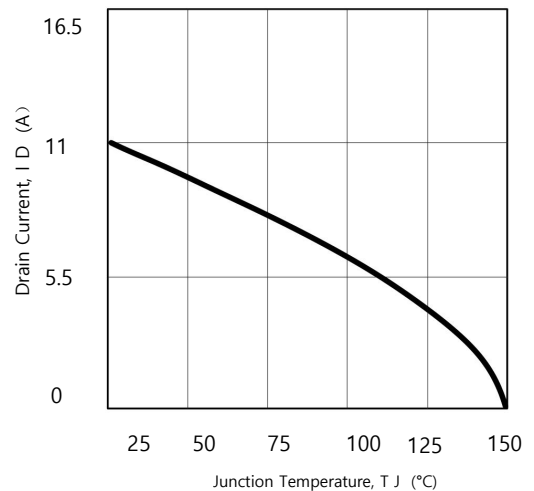

Figure 12. Power Dissipation vs. Junction Temperature

Typical Characteristics (Continued)

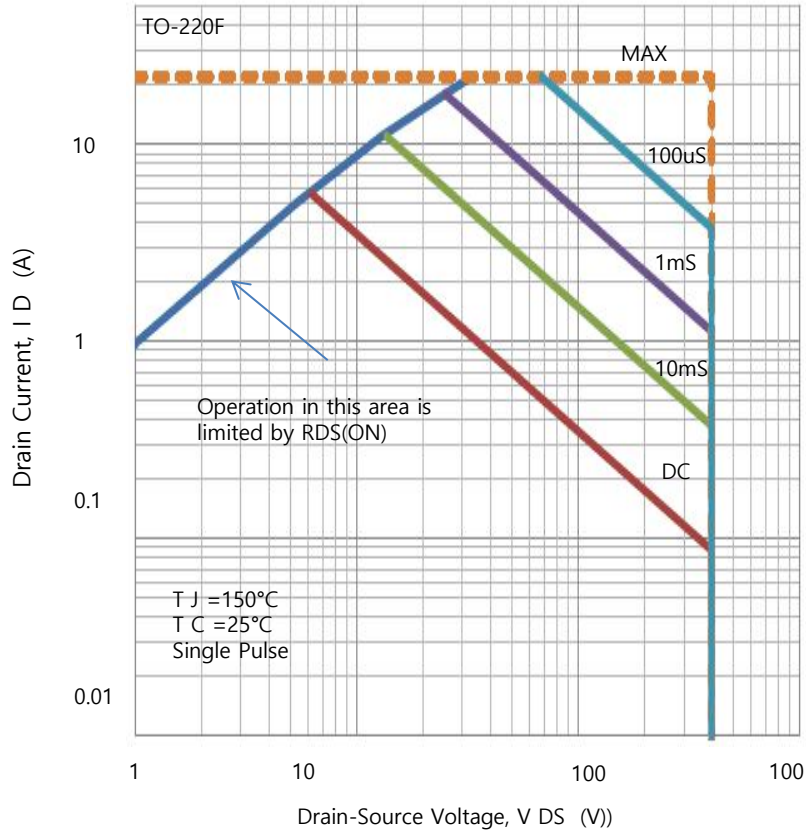
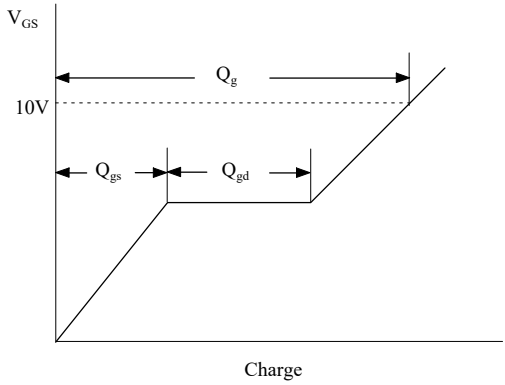
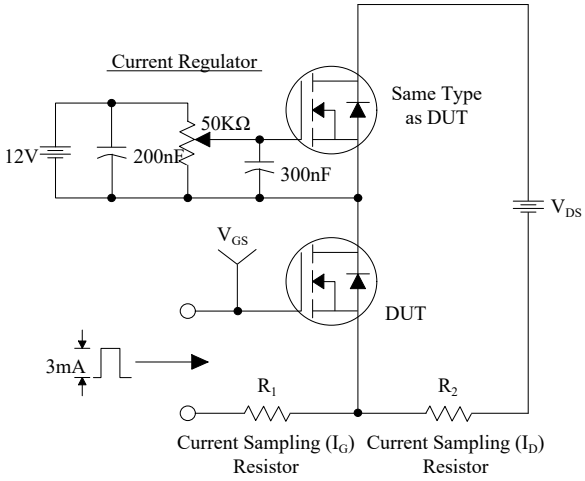
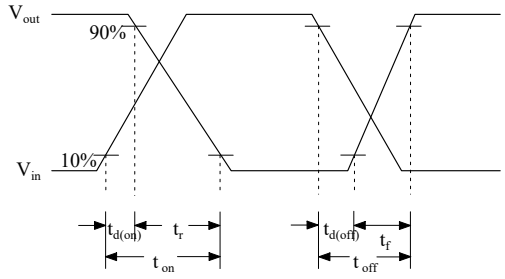
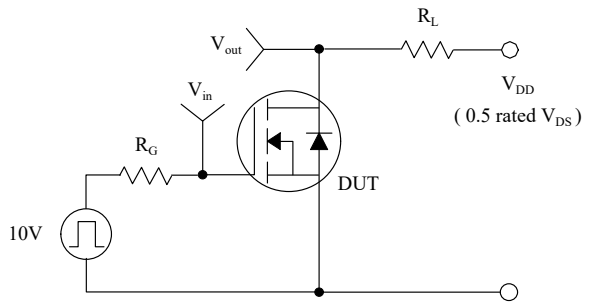

Figure 13 Safe Operating Area

Gate Charge Test Circuit & Waveform



Resistive Switching Test Circuit & Waveforms



Unclamped Inductive Switching Test Circuit & Waveforms

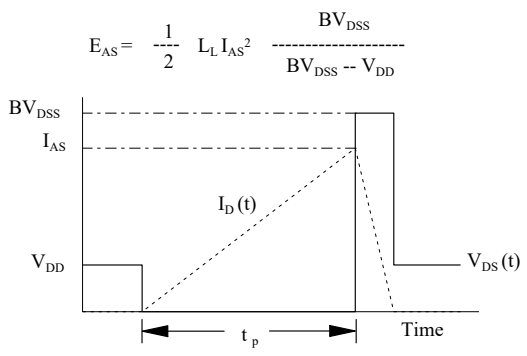
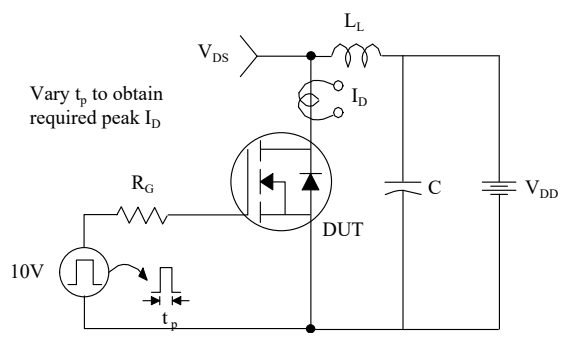

Peak Diode Recovery dv/dt Test Circuit & Waveforms

