

Lonten N-channel 60 V, 80 A, 3.4mΩ Power MOSFET

Features

- Extremely low on-resistance $R_{DS(on)}$
- Excellent $Q_g \times R_{DS(on)}$ product(FOM)
- Qualified according to JEDEC criteria

Product Summary

| | |
|-----------------------|-------|
| V_{DS} | 60V |
| $R_{DS(on)@10V}$ typ | 2.8mΩ |
| $R_{DS(on)@4.5V}$ typ | 3.6mΩ |
| I_D | 80A |

Applications

- Synchronous Rectification for AC/DC QuickCharger
- Battery management
- UPS (Uninterruptible Power Supplies)

100% Avalanche Tested

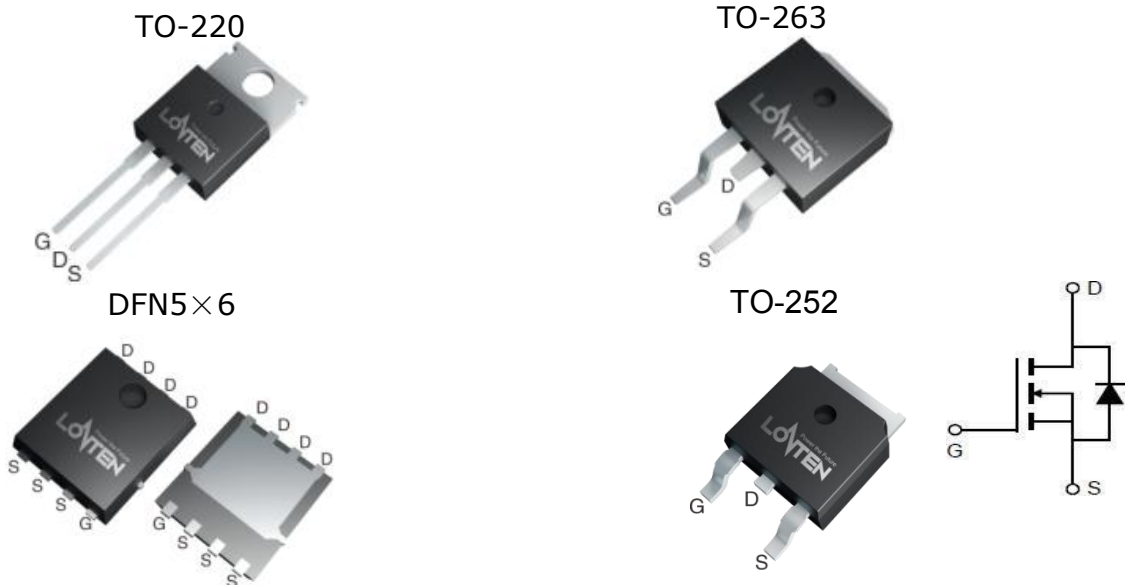

Absolute Maximum Ratings

| Parameter | Symbol | Value | Unit |
|---|----------------|------------|------------------|
| Drain-source voltage | V_{DS} | 60 | V |
| Continuous drain current | I_D | 80 | A |
| $T_C = 25^\circ\text{C}$ (Package limit) | | 117 | |
| $T_C = 25^\circ\text{C}$ (Silicon limit) | | 74 | |
| Pulsed drain current ($T_C = 25^\circ\text{C}$, t_p limited by T_{jmax}) | $I_{D\ pulse}$ | 320 | A |
| Avalanche energy, single pulse ($L=0.3\text{mH}$, $R_g=25\Omega$) | E_{AS} | 135 | mJ |
| Gate-Source voltage | V_{GS} | ± 20 | V |
| Power dissipation ($T_C = 25^\circ\text{C}$) | P_{tot} | 79.1 | W |
| Operating junction and storage temperature | T_j, T_{stg} | -55...+150 | $^\circ\text{C}$ |

Thermal Resistance

| Parameter | Symbol | Max | Unit |
|--|------------|------|------|
| Thermal resistance, junction – case. | R_{thJC} | 1.58 | °C/W |
| Thermal resistance, junction – ambient | R_{thJA} | 47.0 | |

Package Marking and Ordering Information

| Device | Device Package | Marking |
|--------------|----------------|--------------|
| LSGC06R034W3 | TO-220 | LSGC06R034W3 |
| LSGE06R034W3 | TO-263 | LSGE06R034W3 |
| LSGN06R034W3 | DFN5×6 | SGN06R034W3 |
| LSGG06R034W3 | TO-252 | SGG06R034W3 |

Electrical Characteristic (at $T_j = 25\text{ °C}$, unless otherwise specified)

| Parameter | Symbol | Value | | | Unit | Test Condition |
|-----------|--------|-------|------|------|------|----------------|
| | | min. | typ. | max. | | |

Static Characteristic

| | | | | | | |
|----------------------------------|--------------|-----|------|-----|------------|--|
| Drain-source breakdown voltage | BV_{DSS} | 60 | 66 | - | V | $V_{GS}=0V, I_D=250\mu A$ |
| Gate threshold voltage | $V_{GS(th)}$ | 1.2 | 1.7 | 2.2 | V | $V_{DS}=V_{GS}, I_D=250\mu A$ |
| Zero gate voltage drain current | I_{DSS} | - | 0.02 | 1 | μA | $V_{DS}=60V, V_{GS}=0V$ $T_j=25\text{ °C}$ $T_j=125\text{ °C}$ |
| Gate-source leakage current | I_{GSS} | - | 10 | 100 | nA | $V_{GS}=20V, V_{DS}=0V$ |
| Drain-source on-state resistance | $R_{DS(on)}$ | - | 2.8 | 3.4 | m Ω | $V_{GS}=10V, I_D=20A$ |
| | | - | 3.6 | 4.4 | | $V_{GS}=4.5V, I_D=20A$ |
| Transconductance | g_{fs} | - | 102 | - | S | $V_{DS}=5V, I_D=20A$ |

Dynamic Characteristic

| | | | | | | |
|------------------------------|-----------|---|------|---|----|--|
| Input Capacitance | C_{iss} | - | 3224 | - | pF | $V_{GS}=0V, V_{DS}=30V,$ $f=1MHz$ |
| Output Capacitance | C_{oss} | - | 1050 | - | | |
| Reverse Transfer Capacitance | C_{rss} | - | 34 | - | | |
| Gate Total Charge | Q_G | - | 54.2 | - | nC | $V_{GS}=10V, V_{DS}=30V,$ $I_D=20A, f=1MHz$ |
| Gate-Source charge | Q_{gs} | - | 10.2 | - | | |
| Gate-Drain charge | Q_{gd} | - | 7.8 | - | | |

| | | | | | | |
|---------------------|--------------|---|------|---|----------|---|
| Turn-on delay time | $t_{d(on)}$ | - | 11.6 | - | ns | $V_{GS}=10V, V_{DD}=30V,$ $R_{G_ext}=2.7\Omega$ |
| Rise time | t_r | - | 46.5 | - | | |
| Turn-off delay time | $t_{d(off)}$ | - | 47 | - | | |
| Fall time | t_f | - | 58 | - | | |
| Gate resistance | R_G | - | 2.2 | - | Ω | $V_{GS}=0V, V_{DS}=0V,$ $f=1MHz$ |

Body Diode Characteristic

| Parameter | Symbol | Value | | | Unit | Test Condition |
|------------------------------------|----------|-------|------|------|------|--------------------------------|
| | | min. | typ. | max. | | |
| Body Diode Forward Voltage | V_{SD} | - | 0.66 | 0.8 | V | $V_{GS}=0V, I_{SD}=1A$ |
| Body Diode Reverse Recovery Time | t_{rr} | - | 34 | - | ns | $I_F=20A, dI/dt=400A/\mu$ s |
| Body Diode Reverse Recovery Charge | Q_{rr} | - | 100 | - | nC | |

Typical Performance Characteristics

Fig 1: Output Characteristics

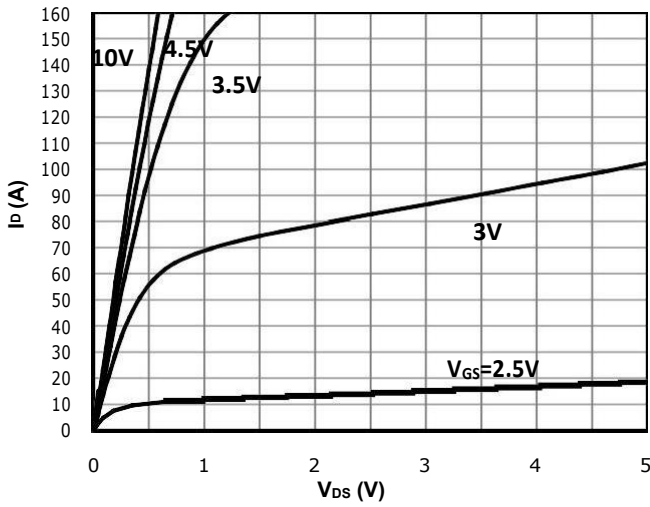

Fig 2: Transfer Characteristics

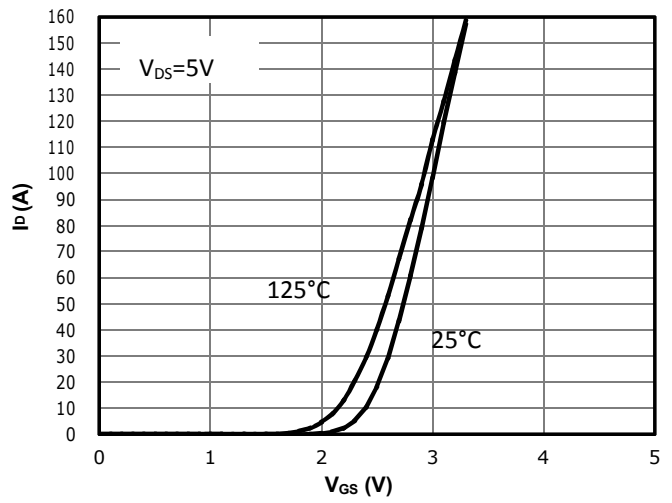

Fig3: $R_{ds(on)}$ vs Drain Current and Gate Voltage

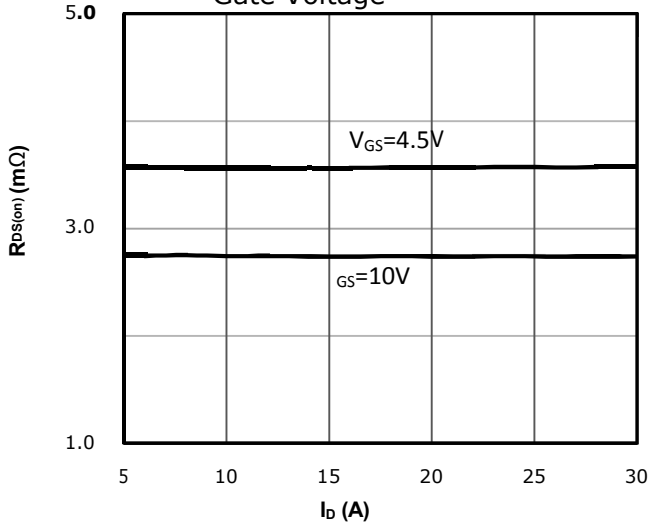

Fig 4: $R_{ds(on)}$ vs Gate Voltage

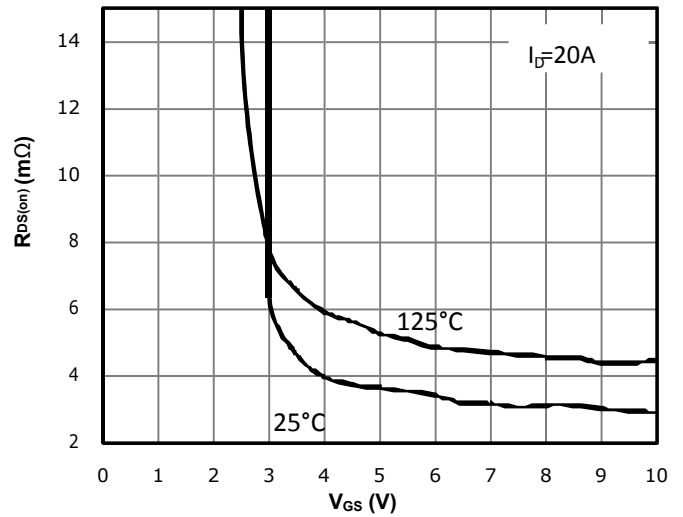

Fig5: $R_{ds(on)}$ vs. Temperature

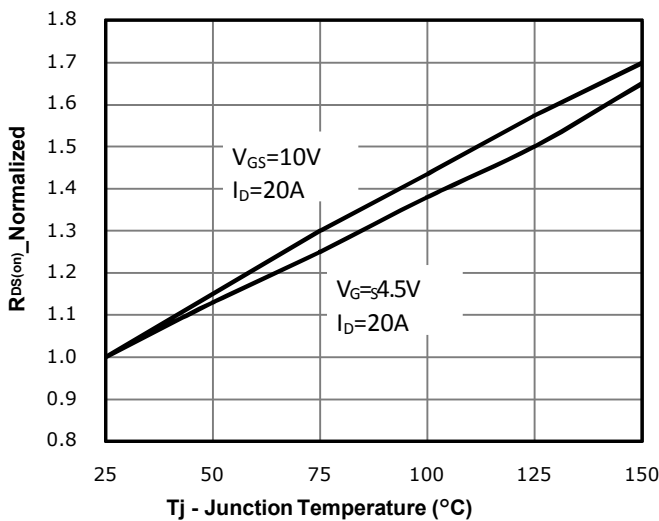

Fig 6: Capacitance Characteristics

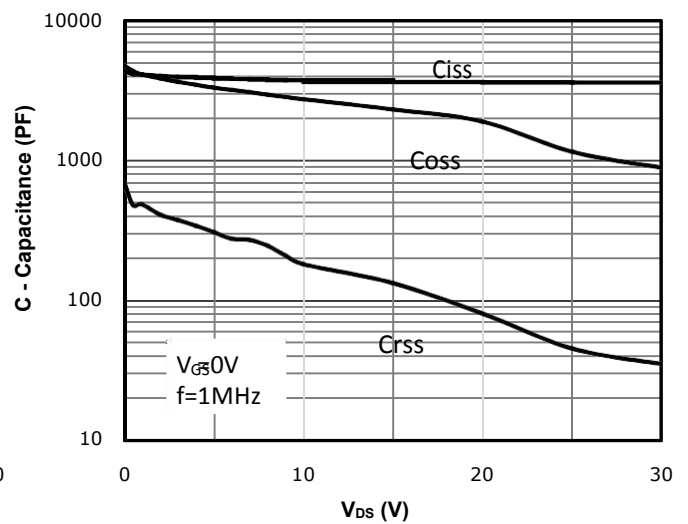

Fig 7: Gate Charge Characteristics

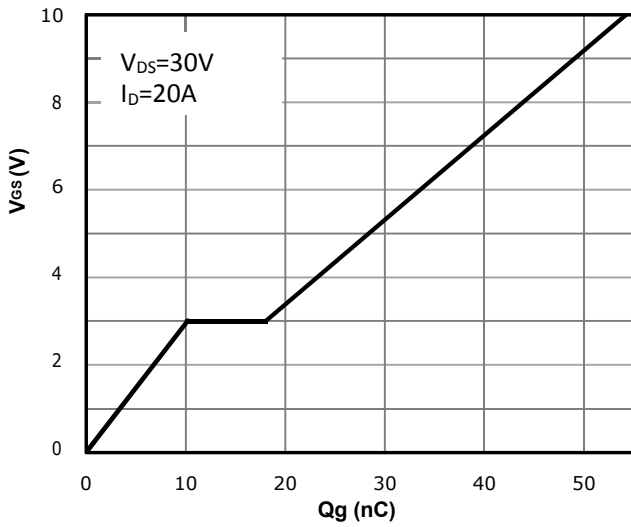

Fig 8: Body-diode Forward Characteristics

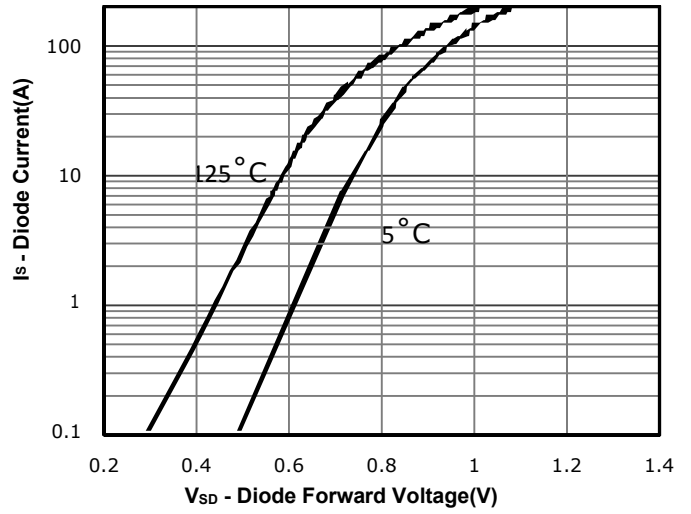

Fig 9: Power Dissipation

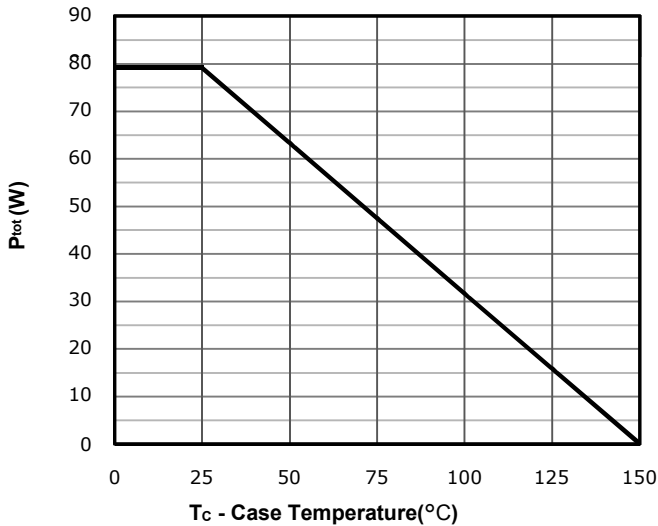

Fig 10: Drain Current Derating

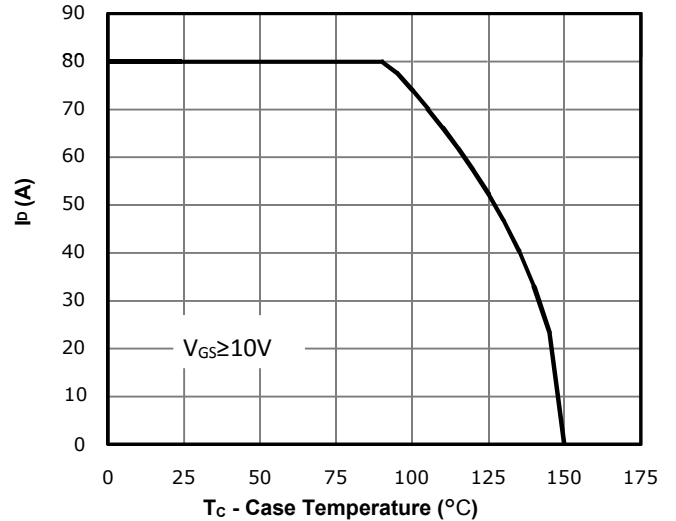

Fig 11: Safe Operating Area

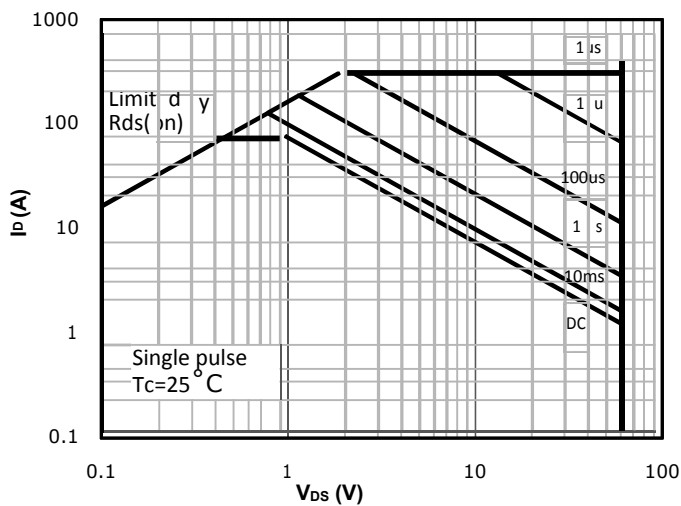
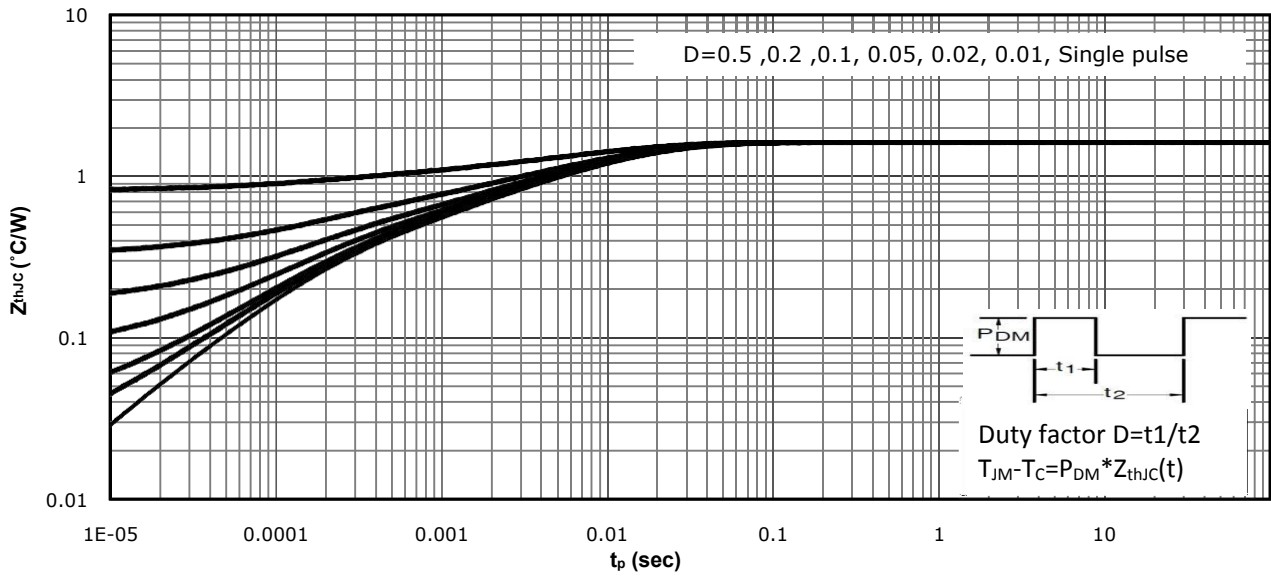
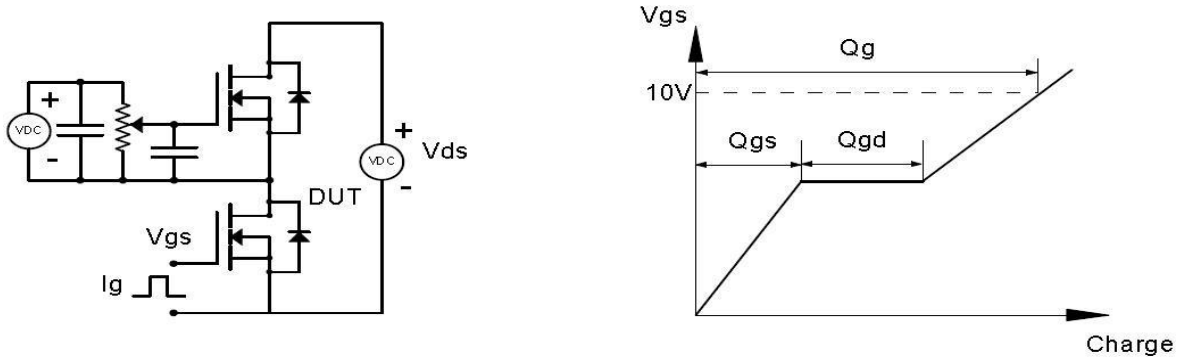

Fig 12: Max. Transient Thermal Impedance



Test Circuit & Waveform

Gate Charge Test Circuit & Waveform



Resistive Switching Test Circuit & Waveforms

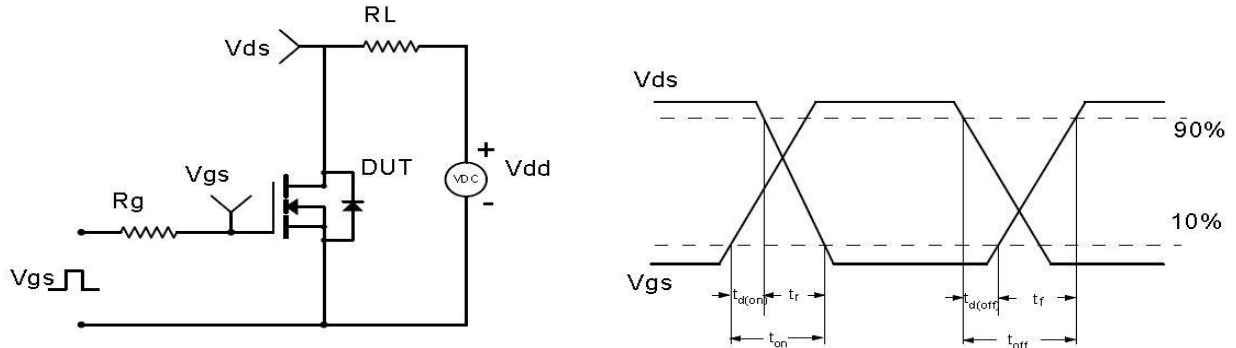

Unclamped Inductive Switching (UIS) Test Circuit & Waveforms

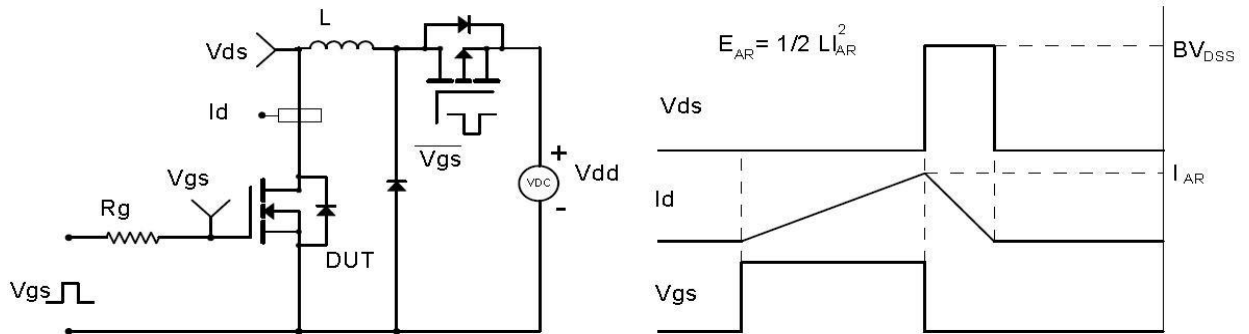

Diode Recovery Test Circuit & Waveforms

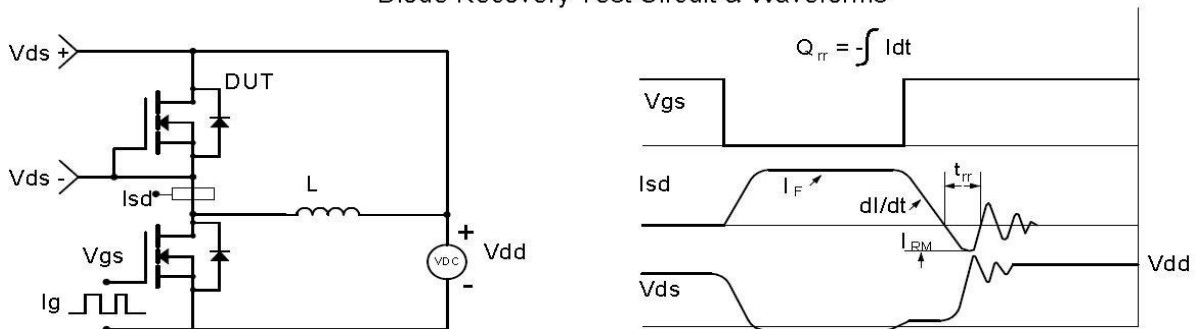

Mechanical Dimensions for TO-220

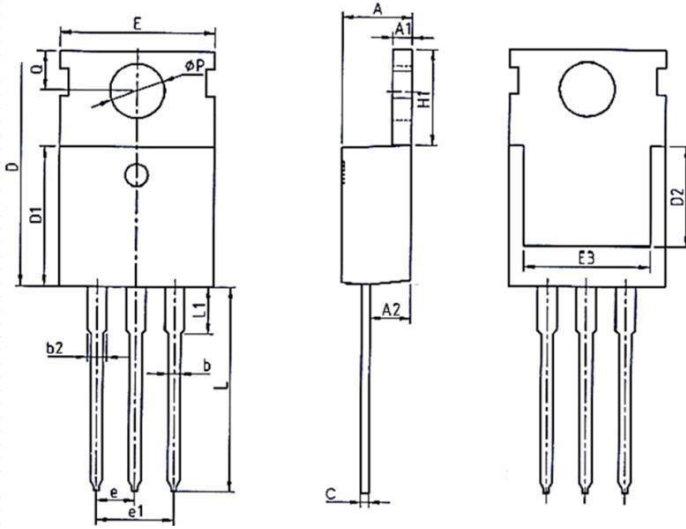

| COMMON DIMENSIONS | | | | | | |
|-------------------|---------|-------|-------|--------|-------|-------|
| SYMBOL | MM | | | INCH | | |
| | MIN | NOM | MAX | MIN | NOM | MAX |
| A | 4.37 | 4.57 | 4.70 | 0.172 | 0.180 | 0.185 |
| A1 | 1.25 | 1.30 | 1.40 | 0.049 | 0.051 | 0.055 |
| A2 | 2.20 | 2.40 | 2.60 | 0.087 | 0.094 | 0.102 |
| b | 0.70 | 0.80 | 0.95 | 0.028 | 0.031 | 0.037 |
| b2 | 1.17 | 1.27 | 1.47 | 0.046 | 0.050 | 0.058 |
| c | 0.45 | 0.50 | 0.60 | 0.018 | 0.020 | 0.024 |
| D | 15.10 | 15.60 | 16.10 | 0.594 | 0.614 | 0.634 |
| D1 | 8.80 | 9.10 | 9.40 | 0.346 | 0.358 | 0.370 |
| D2 | 5.50 | - | - | 0.217 | - | - |
| E | 9.70 | 10.00 | 10.30 | 0.382 | 0.394 | 0.406 |
| E3 | 7.00 | - | - | 0.276 | - | - |
| e | 2.54BCS | | | 0.1BSC | | |
| e1 | 5.08BCS | | | 0.2REF | | |
| H1 | 6.25 | 6.50 | 6.85 | 0.246 | 0.256 | 0.270 |
| L | 12.75 | 13.50 | 13.80 | 0.502 | 0.531 | 0.543 |
| L1 | - | 3.10 | 3.40 | - | 0.122 | 0.134 |
| ØP | 3.40 | 3.60 | 3.80 | 0.134 | 0.142 | 0.150 |
| Q | 2.60 | 2.80 | 3.00 | 0.102 | 0.110 | 0.118 |

TO-220 Part Marking Information

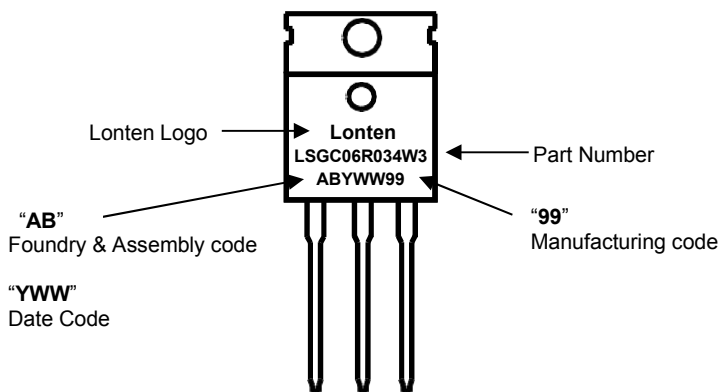

| Calendar Year | Year Code | Calendar Week | Week Code |
|---------------|-----------|---------------|-----------|
| 2019 | H | Workweek 02 | 02 |
| 2020 | I | Workweek 03 | 03 |
| 2021 | J | Workweek 04 | 04 |
| 2022 | K | Workweek 05 | 05 |
| 2023 | L | Workweek 06 | 06 |
| 2024 | M | | |

Mechanical Dimensions for TO-263

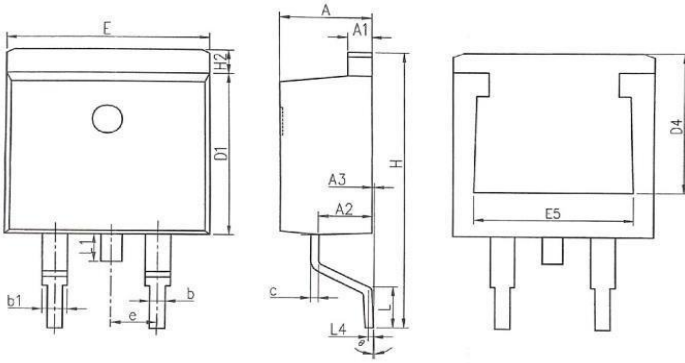

| COMMON DIMENSIONS | | | | | | |
|-------------------|----------|-------|-------|-----------|-------|-------|
| SYMBOL | MM | | | INCH | | |
| | MIN | NOM | MAX | MIN | NOM | MAX |
| A | 4.37 | 4.57 | 4.77 | 0.172 | 0.180 | 0.188 |
| A1 | 1.22 | 1.27 | 1.42 | 0.048 | 0.050 | 0.056 |
| A2 | 2.49 | 2.69 | 2.89 | 0.098 | 0.106 | 0.114 |
| A3 | 0.00 | 0.13 | 0.25 | 0.000 | 0.005 | 0.010 |
| b | 0.70 | 0.81 | 0.96 | 0.028 | 0.032 | 0.038 |
| b1 | 1.17 | 1.27 | 1.47 | 0.046 | 0.050 | 0.058 |
| c | 0.30 | 0.38 | 0.53 | 0.012 | 0.015 | 0.021 |
| D1 | 8.50 | 8.70 | 8.90 | 0.335 | 0.343 | 0.350 |
| D4 | 6.60 | — | — | 0.260 | — | — |
| E | 9.86 | 10.16 | 10.36 | 0.388 | 0.400 | 0.408 |
| E5 | 7.06 | — | — | 0.278 | — | — |
| e | 2.54 BSC | | | 0.100 BSC | | |
| H | 14.70 | 15.10 | 15.50 | 0.579 | 0.594 | 0.610 |
| H2 | 1.07 | 1.27 | 1.47 | 0.042 | 0.050 | 0.058 |
| L | 2.00 | 2.30 | 2.60 | 0.079 | 0.091 | 0.102 |
| L1 | 1.40 | 1.55 | 1.70 | 0.055 | 0.061 | 0.067 |
| L4 | 0.25 BSC | | | 0.010 BSC | | |
| θ | 0° | 5° | 9° | 0° | 5° | 9° |

TO-263 Part Marking Information

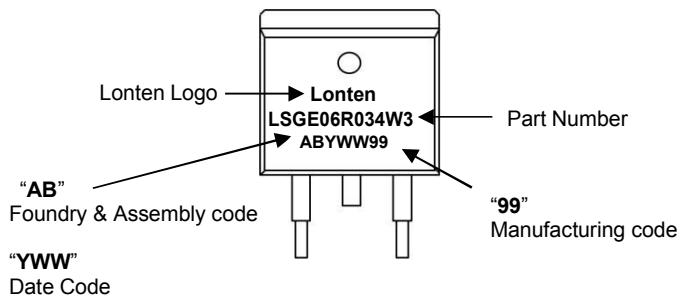

| Calendar Year | Year Code | Calendar Week | Week Code |
|---------------|-----------|---------------|-----------|
| 2019 | H | Workweek 02 | 02 |
| 2020 | I | Workweek 03 | 03 |
| 2021 | J | Workweek 04 | 04 |
| 2022 | K | Workweek 05 | 05 |
| 2023 | L | Workweek 06 | 06 |
| 2024 | M | | |

Mechanical Dimensions for DFN5×6

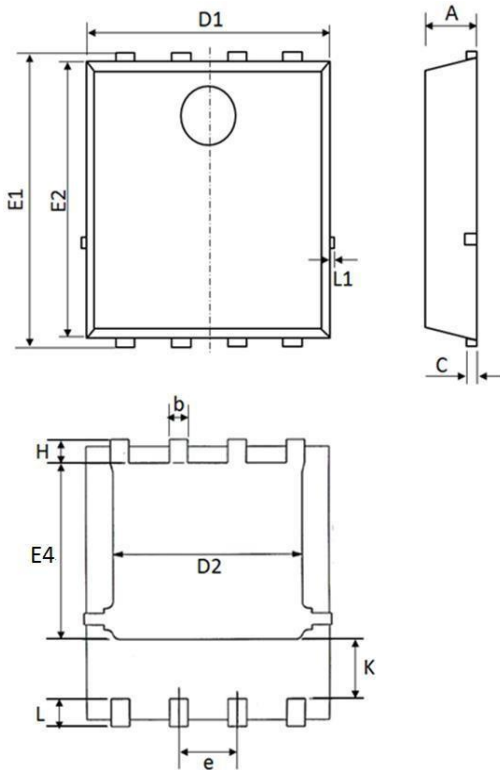

| COMMON DIMENSIONS | | | | | | |
|-------------------|-------------|-------|-------|-----------|-------|-------|
| SYMBOL | MILLIMETERS | | | INCHS | | |
| | MIN | NOM | MAX | MIN | NOM | MAX |
| A | 1 | 1.1 | 1.2 | 0.039 | 0.043 | 0.047 |
| b | 0.3 | 0.4 | 0.5 | 0.012 | 0.016 | 0.020 |
| C | 0.154 | 0.254 | 0.354 | 0.006 | 0.010 | 0.014 |
| D1 | 5 | 5.2 | 5.4 | 0.197 | 0.205 | 0.213 |
| D2 | 3.8 | 4.1 | 4.25 | 0.150 | 0.161 | 0.167 |
| E1 | 5.95 | 6.15 | 6.35 | 0.234 | 0.242 | 0.250 |
| E2 | 5.66 | 5.86 | 6.06 | 0.223 | 0.231 | 0.239 |
| E4 | 3.52 | 3.72 | 3.92 | 0.139 | 0.146 | 0.154 |
| e | 1.27 BSC | | | 0.050 BSC | | |
| H | 0.4 | 0.5 | 0.6 | 0.016 | 0.020 | 0.024 |
| L | 0.5 | 0.6 | 0.7 | 0.020 | 0.024 | 0.028 |
| L1 | - | - | 0.12 | - | - | 0.005 |
| K | 1.14 | 1.29 | 1.44 | 0.045 | 0.051 | 0.057 |

DFN5×6 Part Marking Information

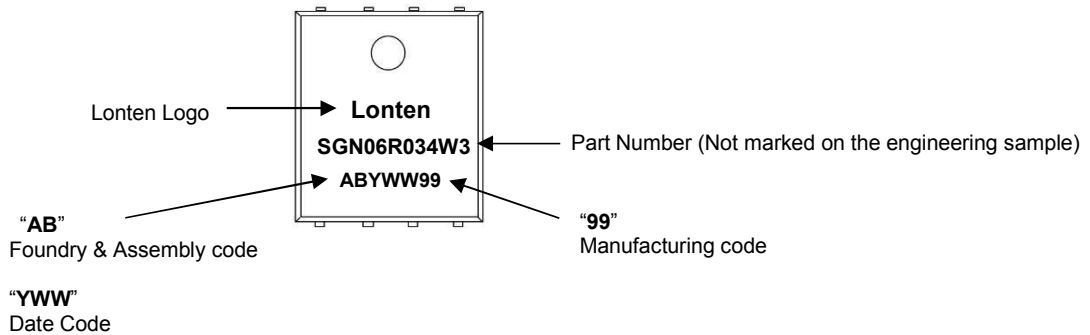

| Calendar Year | Year Code | Calendar Week | Week Code |
|---------------|-----------|---------------|-----------|
| 2018 | G | Workweek 01 | 01 |
| 2019 | H | Workweek 02 | 02 |
| 2020 | I | Workweek 03 | 03 |
| 2021 | J | Workweek 04 | 04 |
| 2022 | K | Workweek 05 | 05 |
| 2023 | L | Workweek 06 | 06 |
| 2024 | M | | |

Mechanical Dimensions for TO-252

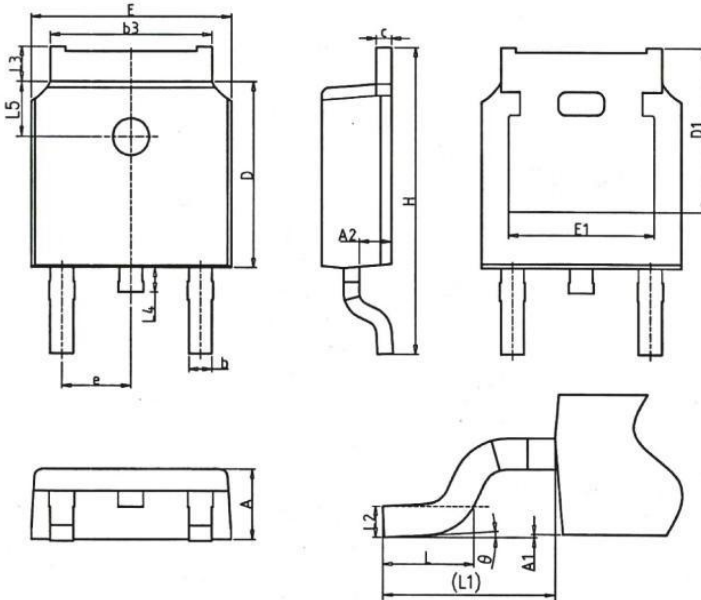

| COMMON DIMENSIONS | | | |
|-------------------|----------|-------|-------|
| SYMBOL | mm | | |
| | MIN | NOM | MAX |
| A | 2.20 | 2.30 | 2.38 |
| A1 | 0.00 | — | 0.20 |
| A2 | 0.97 | 1.07 | 1.17 |
| b | 0.68 | 0.78 | 0.90 |
| b3 | 5.20 | 5.33 | 5.46 |
| c | 0.43 | 0.53 | 0.61 |
| D | 5.98 | 6.10 | 6.22 |
| D1 | 5.30REF | | |
| E | 6.40 | 6.60 | 6.73 |
| E1 | 4.63 | — | — |
| e | 2.286BSC | | |
| H | 9.40 | 10.10 | 10.50 |
| L | 1.38 | 1.50 | 1.75 |
| L1 | 2.90REF | | |
| L2 | 0.51BSC | | |
| L3 | 0.88 | — | 1.28 |
| L4 | 0.50 | — | 1.00 |
| L5 | 1.65 | 1.80 | 1.95 |
| θ | 0° | — | 8° |

TO-252 Part Marking Information

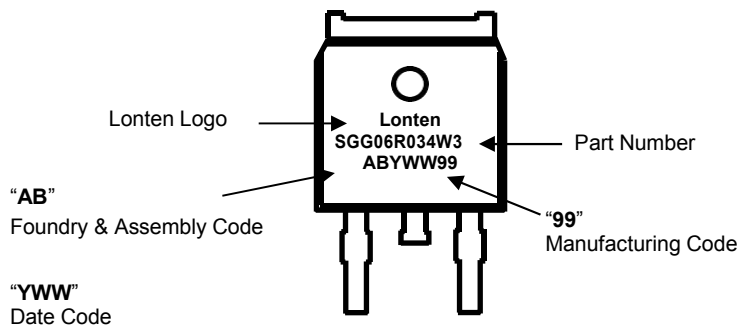

| Calendar Year | Year Code | Calendar Week | Week Code |
|---------------|-----------|---------------|-----------|
| 2018 | G | Workweek 01 | 01 |
| 2019 | H | Workweek 02 | 02 |
| 2020 | I | Workweek 03 | 03 |
| 2021 | J | Workweek 04 | 04 |
| 2022 | K | Workweek 05 | 05 |
| 2023 | L | Workweek 06 | 06 |
| 2024 | M | | |

Disclaimer

The content specified herein is for the purpose of introducing LONTEN's products (hereinafter "Products"). The information given in this document shall in no event be regarded as a guarantee of conditions or characteristics. Examples of application circuits, circuit constants and any other information contained herein illustrate the standard usage and operations of the Products. The peripheral conditions must be taken into account when designing circuits for mass production.

LONTEN does not assume any liability for infringement of patents, copyrights, or other intellectual property rights of third parties by or arising from the use of the Products or technical information described in this document.

The Products are not designed or manufactured to be used with any equipment, device or system which requires an extremely high level of reliability the failure or malfunction of which may result in a direct threat to human life or create a risk of human injury (such as a medical instrument, transportation equipment, aerospace machinery, nuclear-reactor controller, fuel-controller or other safety device). LONTEN shall bear no responsibility in any way for use of any of the Products for the above special purposes.

Although LONTEN endeavors to improve the quality and reliability of its products, semiconductor products have specific characteristics such as the occurrence of failure at a certain rate and malfunctions under certain use conditions. Please be sure to implement safety measures to guard them against the possibility of physical injury, and injury or damage caused by fire in the event of the failure of a LONTEN product.

The content specified herein is subject to change for improvement without notice. When using a LONTEN product, be sure to obtain the latest specifications.