

Description

The HSP200N02 is the highest performance trench N-ch MOSFETs with extreme high cell density, which provide excellent $R_{DS(ON)}$ and gate charge for most of the synchronous buck converter applications.

The HSP200N02 meet the RoHS and Green Product requirement, 100% EAS guaranteed with full function reliability approved.

- Power Switching application
- Green Device Available
- Excellent $C_{dv/dt}$ effect decline
- Advanced high cell density Trench technology

Product Summary

V_{DS}	200	V
$R_{DS(ON),typ}$	27	$m\Omega$
I_D	70	A

TO220 Pin Configuration

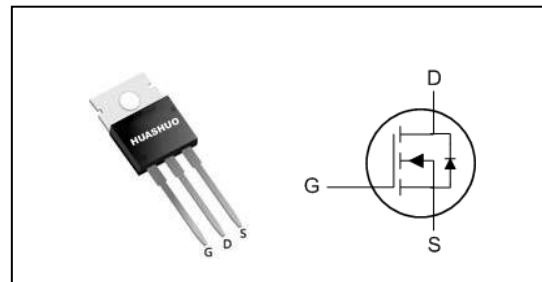

Absolute Maximum Ratings

Symbol	Parameter	Rating	Units
V_{DS}	Drain-Source Voltage	200	V
V_{GS}	Gate-Source Voltage	± 20	V
$I_D@T_C=25^\circ C$	Continuous Drain Current, $V_{GS} @ 10V_1$	70	A
$I_D@T_C=100^\circ C$	Continuous Drain Current, $V_{GS} @ 10V_1$	46	A
I_{DM}	Pulsed Drain Current ₂	252	A
EAS	Single Pulse Avalanche Energy ₃	580	mJ
$P_D@T_C=25^\circ C$	Total Power Dissipation ₃	200	W
T_{STG}	Storage Temperature Range	-55 to 150	$^\circ C$
T_J	Operating Junction Temperature Range	-55 to 150	$^\circ C$

Thermal Data

Symbol	Parameter	Typ.	Max.	Unit
$R_{\theta JA}$	Thermal Resistance Junction-ambient ₁	---	60	$^\circ C/W$
$R_{\theta JC}$	Thermal Resistance Junction-Case ₁	---	0.55	$^\circ C/W$

Electrical Characteristics (T_J=25 °C, unless otherwise noted)

Symbol	Parameter	Conditions	Min.	Typ.	Max.	Unit
B _{VDS}	Drain-Source Breakdown Voltage	V _{GS} =0V, I _D =250uA	200	---	---	V
R _{DS(ON)}	Static Drain-Source On-Resistance ₂	V _{GS} =10V, I _D =30A	---	27	33	mΩ
V _{GS(th)}	Gate Threshold Voltage	V _{GS} =V _{DS} , I _D =250uA	3	---	5	V
I _{DSS}	Drain-Source Leakage Current	V _{DS} =160V, V _{GS} =0V, T _J =25°C	---	---	1	uA
		V _{DS} =160V, V _{GS} =0V, T _J =55°C	---	---	5	
I _{GSS}	Gate-Source Leakage Current	V _{GS} =±20V, V _{DS} =0V	---	---	±100	nA
R _g	Gate Resistance	V _{DS} =0V, V _{GS} =0V, f=1MHz	---	3	---	Ω
Q _g	Total Gate Charge (10V)	V _{DS} =100V, V _{GS} =10V, I _D =30A	---	110	---	nC
Q _{gs}	Gate-Source Charge		---	32	---	
Q _{gd}	Gate-Drain Charge		---	38	---	
T _{d(on)}	Turn-On Delay Time	V _{DD} =100V, V _{GS} =10V, R _G =2.5Ω I _D =30A	---	30	---	ns
T _r	Rise Time		---	18	---	
T _{d(off)}	Turn-Off Delay Time		---	22	---	
T _f	Fall Time		---	33	---	
C _{iss}	Input Capacitance	V _{DS} =25V, V _{GS} =0V, f=1MHz	---	5082	---	pF
C _{oss}	Output Capacitance		---	343	---	
C _{rss}	Reverse Transfer Capacitance		---	129	---	

Diode Characteristics

Symbol	Parameter	Conditions	Min.	Typ.	Max.	Unit
I _S	Continuous Source Current _{1,5}	V _G =V _D =0V, Force Current	---	---	70	A
I _{SM}	Pulsed Source Current _{2,5}		---	---	252	A
V _{SD}	Diode Forward Voltage ₂	V _{GS} =0V, I _S =30A, T _J =25°C	---	---	1.2	V
t _{rr}	Reverse Recovery Time	I _F =30A, dI/dt=100A/μs, T _J =25°C	---	47	---	nS
Q _{rr}	Reverse Recovery Charge		---	81	---	nC

Note :

- 1.The data tested by surface mounted on a 1 inch² FR-4 board with 2OZ copper.
- 2.The data tested by pulsed , pulse width ≤ 300us , duty cycle ≤ 2%
- 3.The EAS data shows Max. rating . The test condition is V_{DD}=25V,V_{GS}=10V,L=0.3mH
- 4.The power dissipation is limited by 150°C junction temperature
- 5.The data is theoretically the same as I_D and I_{DM} , in real applications , should be limited by total power dissipation.

Typical Characteristics

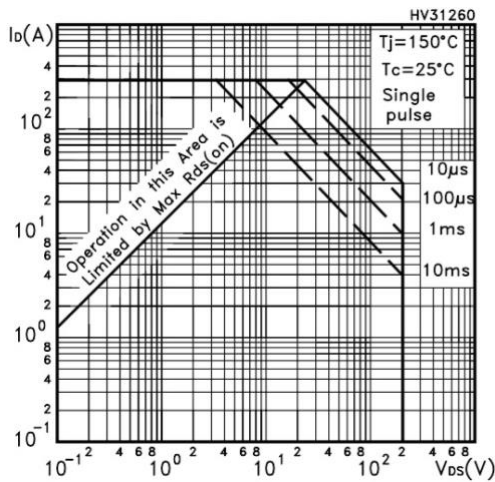

Fig.1 Safe operating area for TO-220

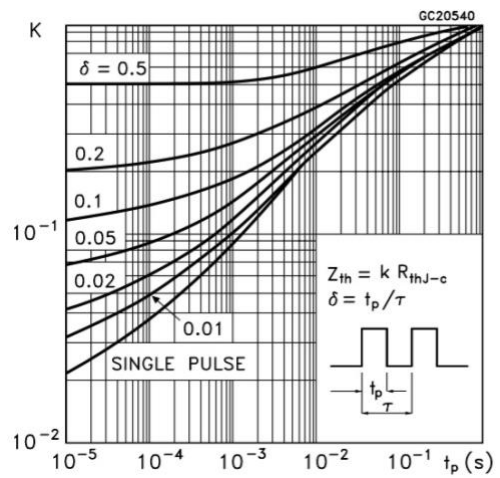

Fig.2 Thermal impedance for TO-220

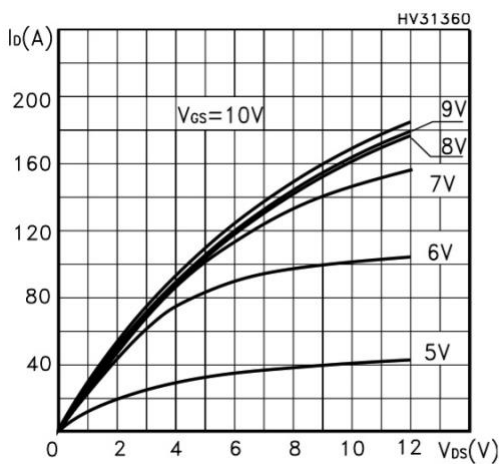

Fig.3 Output characteristics

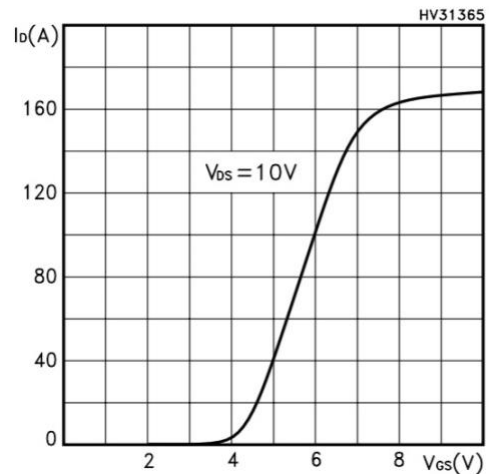

Fig.4 Transfer characteristics

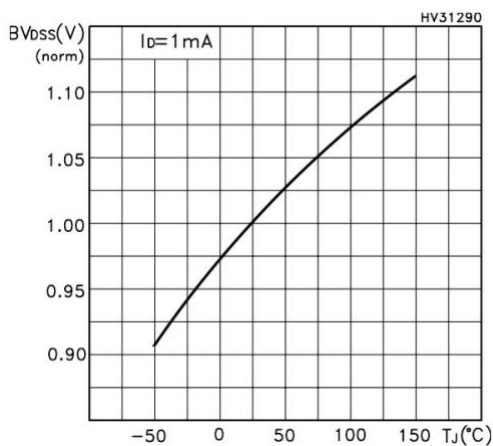

Fig.5 Normalized BVDSS vs temperature

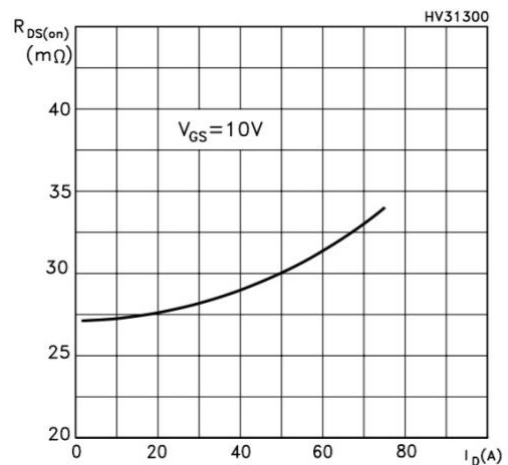

Fig.6 Static drain-source on resistance

N-Ch 200V Fast Switching MOSFETs

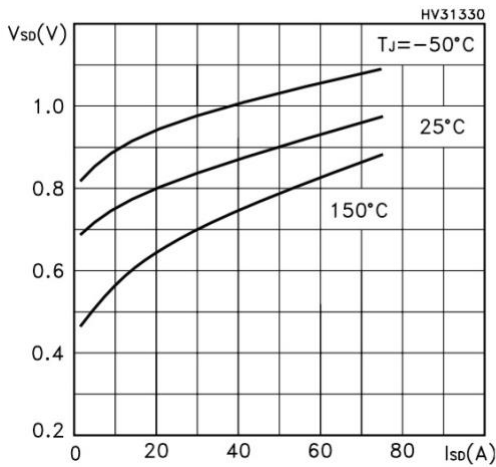

Fig.7 Source-drain diode forward characteristics

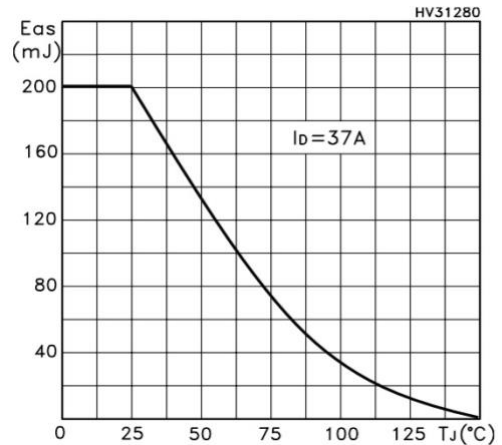

Fig.8 Avalanche energy vs starting \$T_J\$

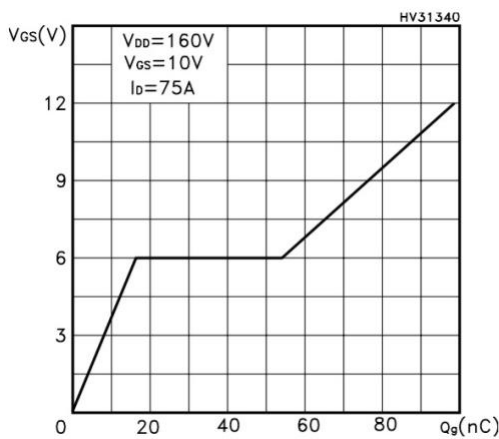

Fig.9 Gate charge vs gate-source voltage

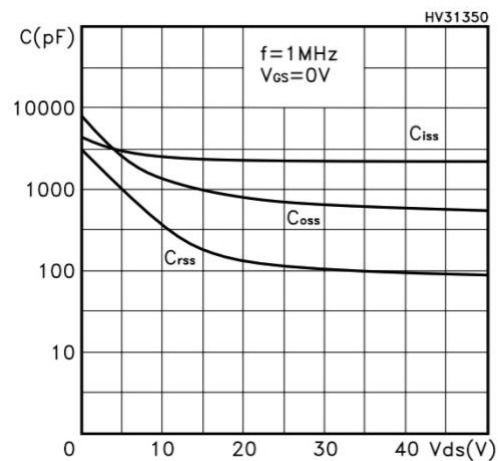

Fig.10 Capacitance variations

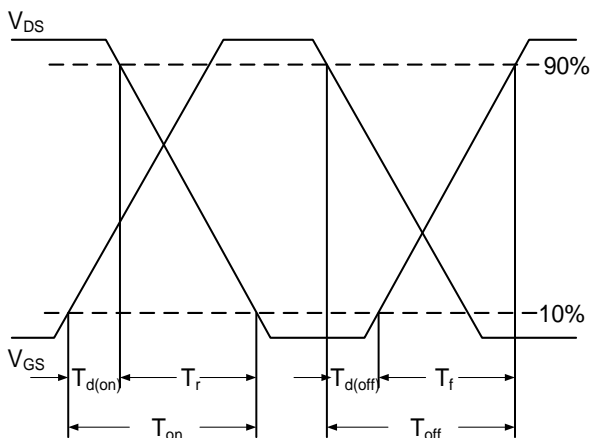

Fig.11 Switching Time Waveform

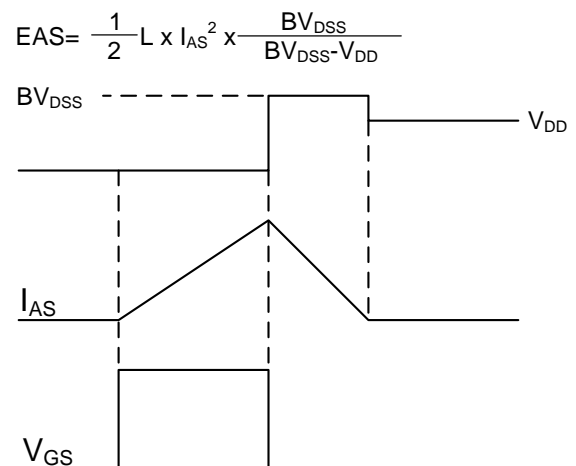
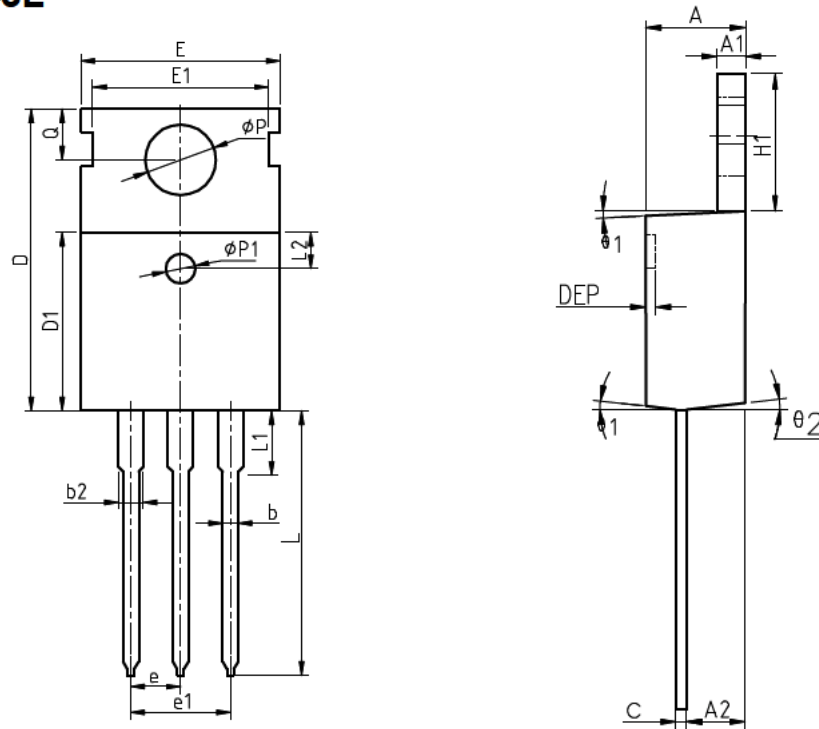

Fig.12 Unclamped Inductive Switching



Package Information

TO-220FB-3L



COMMON DIMENSIONS

SYMBOL	MIN	NOM	MAX	MIN	NOM	MAX
A	4.40	4.57	4.70	0.173	0.180	0.185
A1	1.27	1.30	1.33	0.050	0.051	0.052
A2	2.35	2.40	2.50	0.093	0.094	0.098
b	0.77	0.80	0.90	0.030	0.031	0.035
b2	1.17	1.27	1.36	0.046	0.050	0.054
c	0.48	0.50	0.56	0.019	0.020	0.022
D	15.40	15.60	15.80	0.606	0.614	0.622
D1	9.00	9.10	9.20	0.354	0.358	0.362
DEP	0.05	0.10	0.20	0.002	0.004	0.008
E	9.80	10.00	10.20	0.386	0.394	0.402
E1	-	8.70	-	-	0.343	-
E2	9.80	10.00	10.20	0.386	0.394	0.402
e		2.54	BSC		0.100	BSC
e1		5.08	BSC		0.200	BSC
H1	6.40	6.50	6.60	0.252	0.256	0.260
L	12.75	13.50	13.65	0.502	0.531	0.537
L1	-	3.10	3.30	-	0.122	0.130
L2		2.50	REF		0.098	REF
P	3.50	3.60	3.63	0.138	0.142	0.143
P1	3.50	3.60	3.63	0.138	0.142	0.143
Q	2.73	2.80	2.87	0.107	0.110	0.113
theta 1	5°	7°	9°	5°	7°	9°
theta 2	1°	3°	5°	1°	3°	5°
theta 3	1°	3°	5°	1°	3°	5°

