

# SINGLE-SUPPLY, RAIL-TO-RAIL OPERATIONAL AMPLIFIERS

## FEATURES

- RAIL-TO-RAIL INPUT
- RAIL-TO-RAIL OUTPUT (within 1mV)
- *Micro*SIZE PACKAGES
- WIDE BANDWIDTH: 5.5MHz
- HIGH SLEW RATE: 6V/μs
- LOW THD+NOISE: 0.0007% (f = 1kHz)
- LOW QUIESCENT CURRENT: 750μA/channel
- SINGLE, DUAL, AND QUAD

## DESCRIPTION

OPA340 series rail-to-rail CMOS operational amplifiers are optimized for low voltage, single supply operation. Rail-to-rail input/output and high speed operation make them ideal for driving sampling analog-to-digital converters. They are also well suited for general purpose and audio applications as well as providing I/V conversion at the output of D/A converters. Single, dual, and quad versions have identical specifications for design flexibility.

The OPA340 series operates on a single supply as low as 2.5V with an input common-mode voltage range that extends 500mV below ground and 500mV above the positive supply. Output voltage swing is to within 1mV

## APPLICATIONS

- DRIVING A/D CONVERTERS
- PCMCIA CARDS
- DATA ACQUISITION
- PROCESS CONTROL
- AUDIO PROCESSING
- COMMUNICATIONS
- ACTIVE FILTERS
- TEST EQUIPMENT

of the supply rails with a 100kΩ load. They offer excellent dynamic response (BW = 5.5MHz, SR = 6V/μs), yet quiescent current is only 750μA. Dual and quad designs feature completely independent circuitry for lowest crosstalk and freedom from interaction.

The single (OPA340) packages are the tiny 5-lead SOT-23-5 surface mount, SO-8 surface mount, and 8-pin DIP. The dual (OPA2340) comes in the miniature MSOP-8 surface mount, SO-8 surface mount, and 8-pin DIP packages. The quad (OPA4340) packages are the space-saving SSOP-16 surface mount, SO-14 surface mount, and the 14-pin DIP. All are specified from -40°C to +85°C and operate from -55°C to +125°C. A SPICE macromodel is available for design analysis.

## PIN CONFIGURATIONS

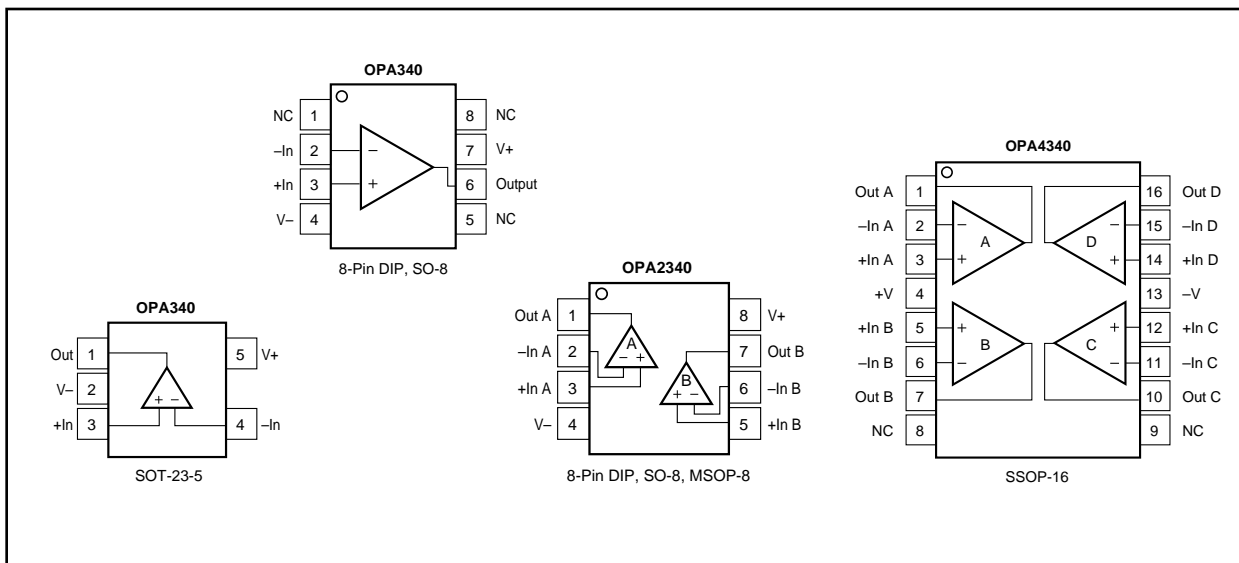

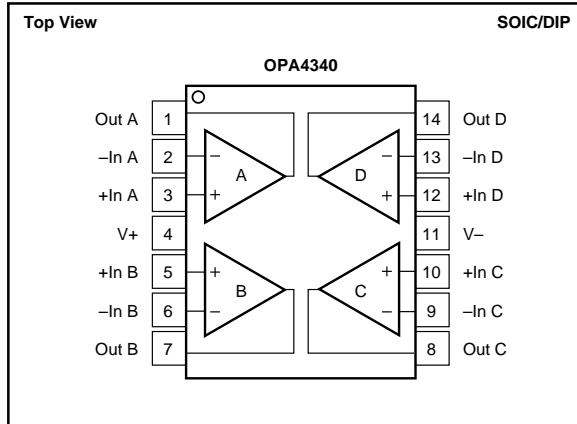
**PIN CONFIGURATIONS**

**ELECTROSTATIC DISCHARGE SENSITIVITY**

This integrated circuit can be damaged by ESD. Burr-Brown recommends that all integrated circuits be handled with appropriate precautions. Failure to observe proper handling and installation procedures can cause damage.

ESD damage can range from subtle performance degradation to complete device failure. Precision integrated circuits may be more susceptible to damage because very small parametric changes could cause the device not to meet its published specifications.

**ABSOLUTE MAXIMUM RATINGS<sup>(1)</sup>**

Supply Voltage .....	5.5V
Signal Input Terminals, Voltage <sup>(2)</sup> .....	(V-) -0.5V to (V+) +0.5V
Current <sup>(2)</sup> .....	10mA
Output Short-Circuit <sup>(3)</sup> .....	Continuous
Operating Temperature .....	-55°C to +125°C
Storage Temperature .....	-55°C to +125°C
Junction Temperature .....	150°C
Lead Temperature (soldering, 10s) .....	300°C

NOTES: (1) Stresses above these ratings may cause permanent damage.  
 (2) Input terminals are diode-clamped to the power supply rails. Input signals that can swing more than 0.5V beyond the supply rails should be current-limited to 10mA or less. (3) Short-circuit to ground, one amplifier per package.

**PACKAGE/ORDERING INFORMATION**

PRODUCT	PACKAGE	PACKAGE DRAWING NUMBER <sup>(1)</sup>	SPECIFIED TEMPERATURE RANGE	PACKAGE MARKING	ORDERING NUMBER <sup>(2)</sup>	TRANSPORT MEDIA
<b>Single</b>						
OPA340NA	5-Lead SOT-23-5	331	-40°C to +85°C	A40	OPA340NA-250	Tape and Reel
OPA340PA	8-Pin DIP	006	-40°C to +85°C	OPA340PA	OPA340NA-3K	Tape and Reel
OPA340UA	SO-8 Surface-Mount	182	-40°C to +85°C	OPA340UA	OPA340PA	Rails
					OPA340UA	Rails <sup>(3)</sup>
<b>Dual</b>						
OPA2340EA	MSOP-8 Surface-Mount	337	-40°C to +85°C	A40A	OPA2340EA-250	Tape and Reel
OPA2340PA	8-Pin DIP	006	-40°C to +85°C	OPA2340PA	OPA2340EA-2500	Tape and Reel
OPA2340UA	SO-8 Surface-Mount	182	-40°C to +85°C	OPA2340UA	OPA2340PA	Rails
					OPA2340UA	Rails <sup>(3)</sup>
<b>Quad</b>						
OPA4340EA	SSOP-16 Surface-Mount	322	-40°C to +85°C	OPA4340EA	OPA4340EA-250	Tape and Reel
OPA4340PA	14-Pin DIP	010	-40°C to +85°C	OPA4340PA	OPA4340EA-2500	Tape and Reel
OPA4340UA	SO-14 Surface Mount	235	-40°C to +85°C	OPA4340UA	OPA4340PA	Rails
					OPA4340UA	Rails <sup>(3)</sup>

NOTES: (1) For detailed drawing and dimension table, please see end of data sheet.

**SPECIFICATIONS:  $V_S = 2.7V$  to  $5V$** 

At  $T_A = +25^\circ C$ ,  $R_L = 10k\Omega$  connected to  $V_S/2$  and  $V_{OUT} = V_S/2$ , unless otherwise noted.  
**Boldface** limits apply over the specified temperature range,  $T_A = -40^\circ C$  to  $+85^\circ C$ .  $V_S = 5V$ .

PARAMETER	CONDITION	OPA340NA, PA, UA OPA2340EA, PA, UA OPA4340EA, PA, UA			UNITS
		MIN	TYP <sup>(1)</sup>	MAX	
<b>OFFSET VOLTAGE</b> Input Offset Voltage $V_{OS}$ vs Temperature $dV_{OS}/dT$ vs Power Supply PSRR $T_A = -40^\circ C$ to $+85^\circ C$ Channel Separation, dc	$V_S = 5V$  $V_S = 2.7V$ to $5.5V$ , $V_{CM} = 0V$ $V_S = 2.7V$ to $5.5V$ , $V_{CM} = 0V$		$\pm 150$ <b><math>\pm 2.5</math></b> 30  0.2	$\pm 500$  120 <b>120</b>	$\mu V$ $\mu V/^\circ C$ $\mu V/V$ $\mu V/V$ $\mu V/V$
<b>INPUT BIAS CURRENT</b> Input Bias Current $I_B$ $T_A = -40^\circ C$ to $+85^\circ C$ Input Offset Current $I_{OS}$			$\pm 0.2$  $\pm 0.2$	$\pm 10$ <b><math>\pm 60</math></b> $\pm 10$	pA pA pA
<b>NOISE</b> Input Voltage Noise, $f = 0.1$ to $50kHz$ Input Voltage Noise Density, $f = 1kHz$ $e_n$ Current Noise Density, $f = 1kHz$ $i_n$			8 25 3		$\mu V_{rms}$ $nV/\sqrt{Hz}$ $fA/\sqrt{Hz}$
<b>INPUT VOLTAGE RANGE</b> Common-Mode Voltage Range $V_{CM}$ Common-Mode Rejection Ratio CMRR	$-0.3V < V_{CM} < (V+) - 1.8V$ $V_S = 5V$ , $-0.3V < V_{CM} < 5.3V$ $V_S = 2.7V$ , $-0.3V < V_{CM} < 3V$	-0.3 80 70 66	92 84 80	(V+) +0.3	V dB dB dB
<b>INPUT IMPEDANCE</b> Differential Common-Mode			$10^{13} \parallel 3$ $10^{13} \parallel 6$		$\Omega \parallel pF$ $\Omega \parallel pF$
<b>OPEN-LOOP GAIN</b> Open-Loop Voltage Gain $A_{OL}$ $T_A = -40^\circ C$ to $+85^\circ C$  $T_A = -40^\circ C$ to $+85^\circ C$  $T_A = -40^\circ C$ to $+85^\circ C$	$R_L = 100k\Omega$ , $5mV < V_O < (V+) - 5mV$ $R_L = 100k\Omega$ , $5mV < V_O < (V+) - 5mV$ $R_L = 10k\Omega$ , $50mV < V_O < (V+) - 50mV$ $R_L = 10k\Omega$ , $50mV < V_O < (V+) - 50mV$ $R_L = 2k\Omega$ , $200mV < V_O < (V+) - 200mV$ $R_L = 2k\Omega$ , $200mV < V_O < (V+) - 200mV$	106 <b>106</b> 100 <b>100</b> 94 <b>94</b>	124  120  114		dB dB dB dB dB dB
<b>FREQUENCY RESPONSE</b> Gain-Bandwidth Product GBW Slew Rate SR Settling Time, 0.1% 0.01% Overload Recovery Time Total Harmonic Distortion + Noise THD+N	$G = 1$ $V_S = 5V$ , $G = 1$ , $C_L = 100pF$ $V_S = 5V$ , 2V Step, $C_L = 100pF$ $V_S = 5V$ , 2V Step, $C_L = 100pF$ $V_{IN} \cdot G = V_S$ $V_S = 5V$ , $V_O = 3V_{pp}$ , $G = 1$ , $f = 1kHz$		5.5 6 1 1.6 0.2 0.0007		MHz V/ $\mu s$ $\mu s$ $\mu s$ $\mu s$ %
<b>OUTPUT</b> Voltage Output Swing from Rail <sup>(3)</sup> $T_A = -40^\circ C$ to $+85^\circ C$  $T_A = -40^\circ C$ to $+85^\circ C$  $T_A = -40^\circ C$ to $+85^\circ C$ Short-Circuit Current $I_{SC}$ Capacitive Load Drive $C_{LOAD}$	$R_L = 100k\Omega$ , $A_{OL} \geq 106dB$ $R_L = 100k\Omega$ , $A_{OL} \geq 106dB$ $R_L = 10k\Omega$ , $A_{OL} \geq 100dB$ $R_L = 10k\Omega$ , $A_{OL} \geq 100dB$ $R_L = 2k\Omega$ , $A_{OL} \geq 94dB$ $R_L = 2k\Omega$ , $A_{OL} \geq 94dB$		1 10 40  $\pm 50$	5 <b>5</b> 50 <b>50</b> 200 <b>200</b>	mV mV mV mV mV mV mA
<b>POWER SUPPLY</b> Specified Voltage Range $V_S$ Operating Voltage Range Quiescent Current (per amplifier) $I_Q$ $T_A = -40^\circ C$ to $+85^\circ C$	$I_O = 0$ , $V_S = +5V$ $I_O = 0$ , $V_S = +5V$	2.7	2.5 to 5.5 750	5  950 <b>1100</b>	V V $\mu A$ $\mu A$
<b>TEMPERATURE RANGE</b> Specified Range Operating Range Storage Range Thermal Resistance $\theta_{JA}$ SOT-23-5 Surface Mount MSOP-8 Surface Mount SO-8 Surface Mount 8-Pin DIP SSOP-16 Surface Mount SO-14 Surface Mount 14-Pin DIP		-40 -55 -55		+85 +125 +125	$^\circ C$ $^\circ C$ $^\circ C$ $^\circ C/W$ $^\circ C/W$ $^\circ C/W$ $^\circ C/W$ $^\circ C/W$ $^\circ C/W$ $^\circ C/W$

NOTES: (1)  $V_S = +5V$ . (2)  $V_{OUT} = 0.25V$  to  $3.25V$ . (3) Output voltage swings are measured between the output and power supply rails.

**TYPICAL PERFORMANCE CURVES**

At  $T_A = +25^\circ\text{C}$ ,  $V_S = +5\text{V}$ , and  $R_L = 10\text{k}\Omega$  connected to  $V_S/2$ , unless otherwise noted.

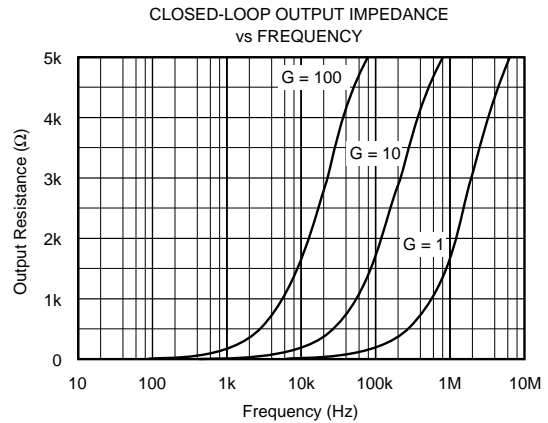
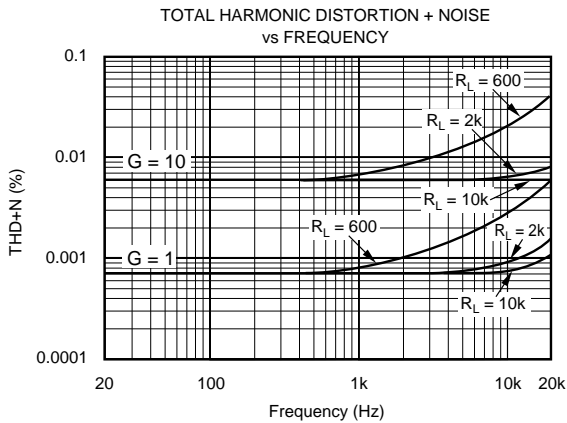
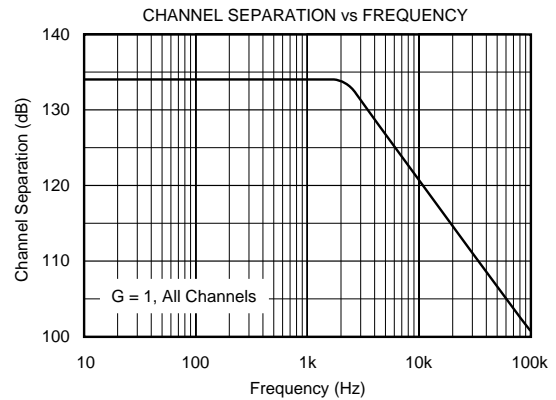
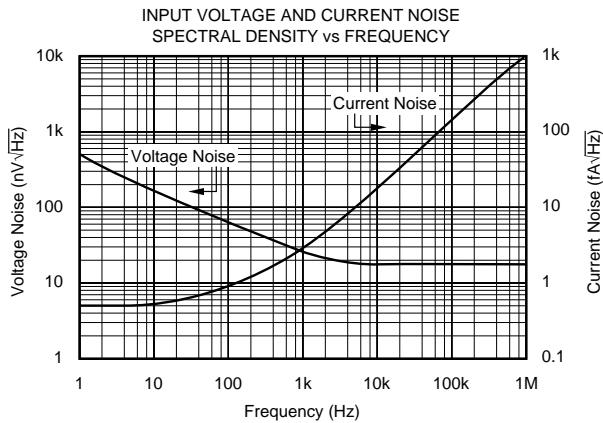
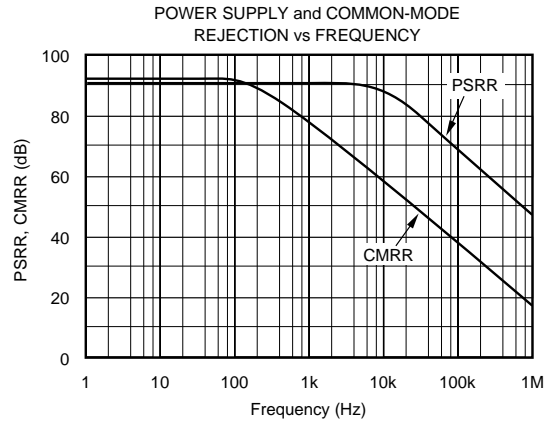
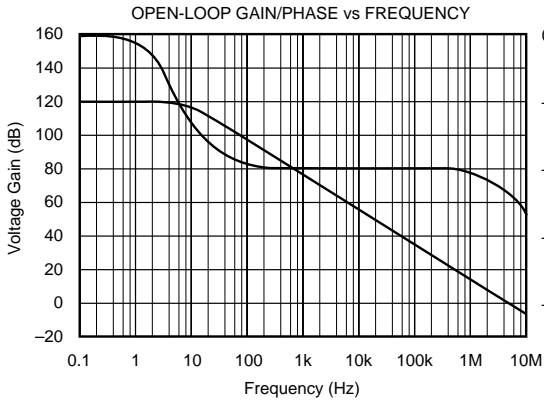

## TYPICAL PERFORMANCE CURVES (CONT)

At  $T_A = +25^\circ\text{C}$ ,  $V_S = +5\text{V}$ , and  $R_L = 10\text{k}\Omega$  connected to  $V_S/2$ , unless otherwise noted.

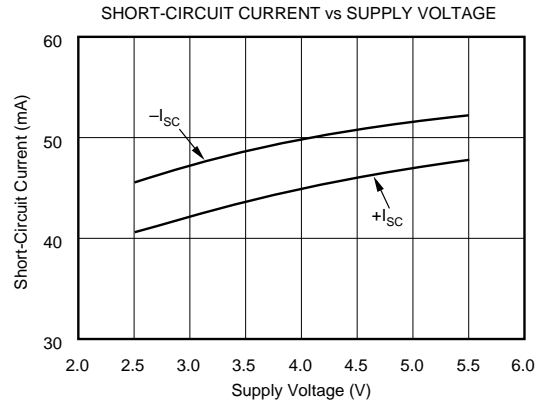
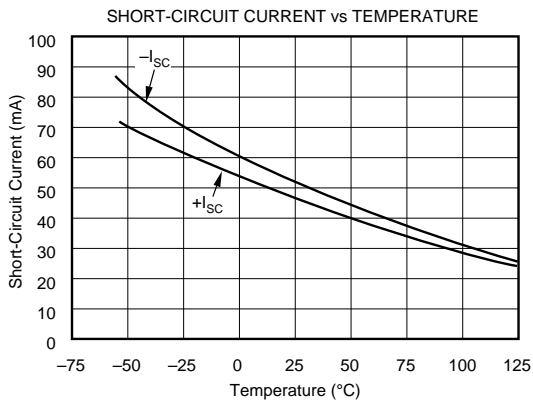
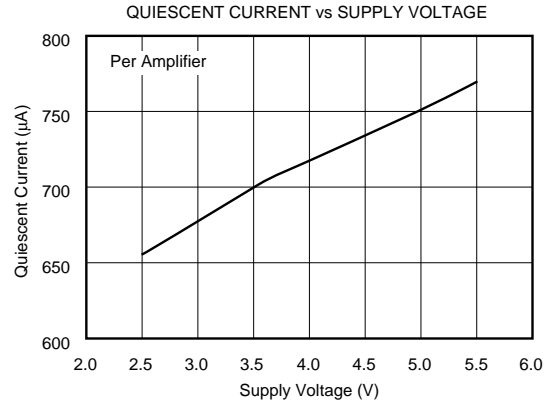
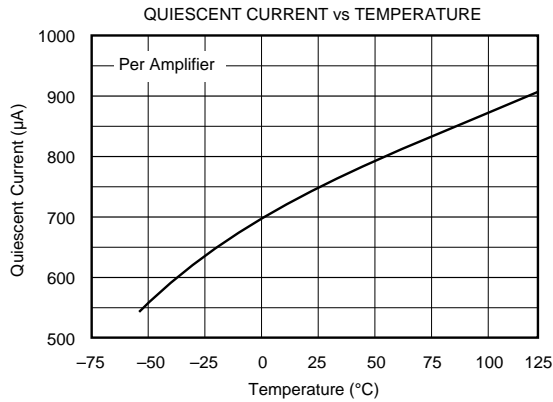
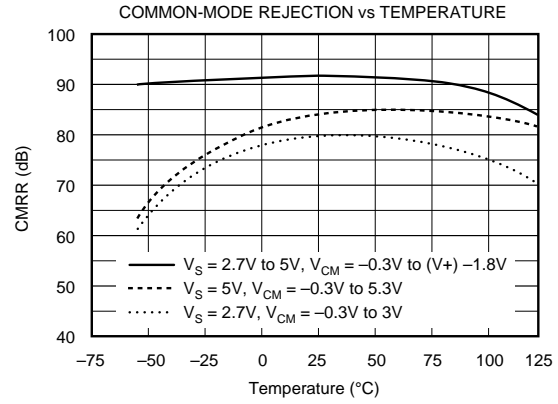
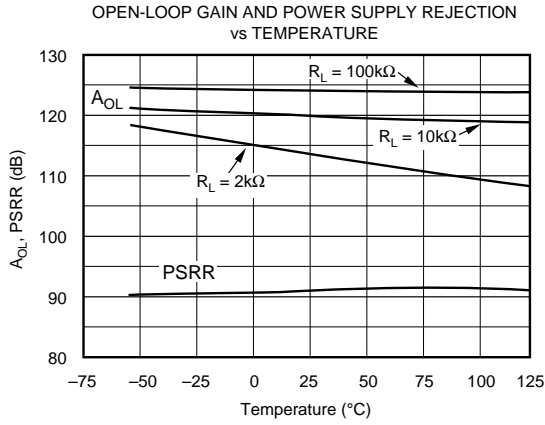

**TYPICAL PERFORMANCE CURVES (CONT)**

At  $T_A = +25^\circ\text{C}$ ,  $V_S = +5\text{V}$ , and  $R_L = 10\text{k}\Omega$  connected to  $V_S/2$ , unless otherwise noted.

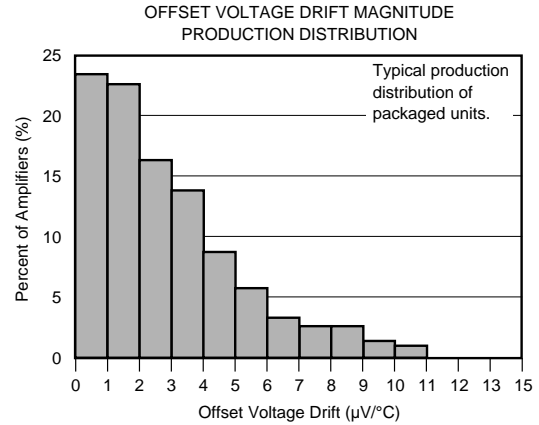
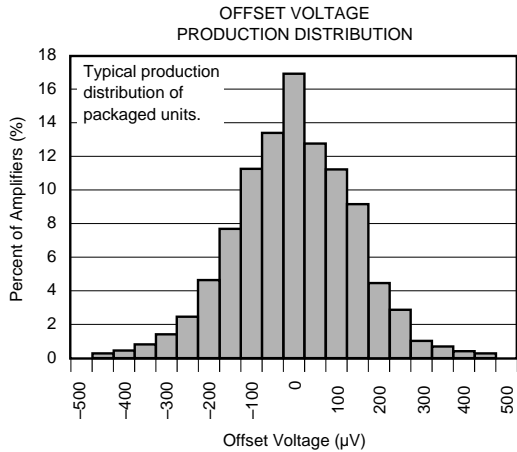
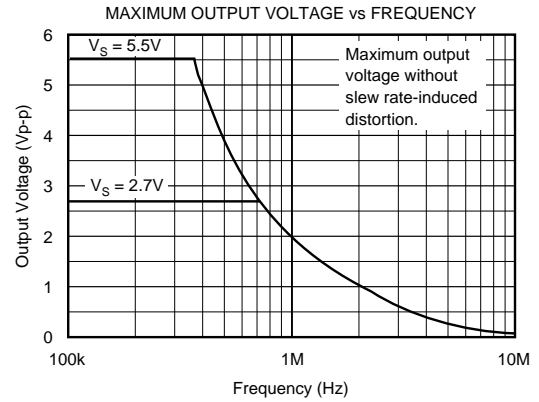
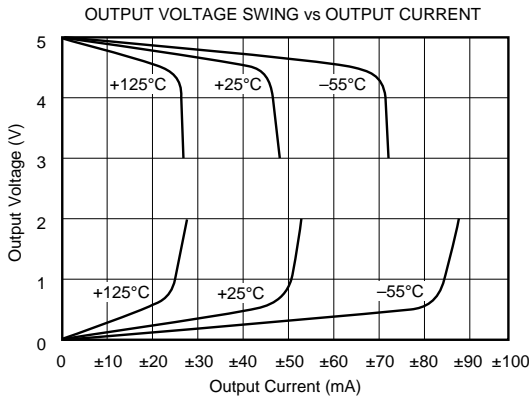
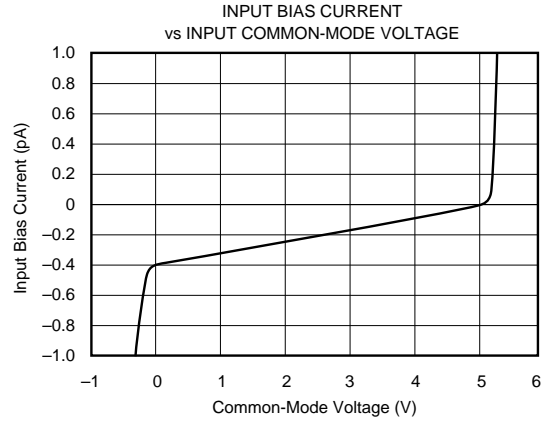
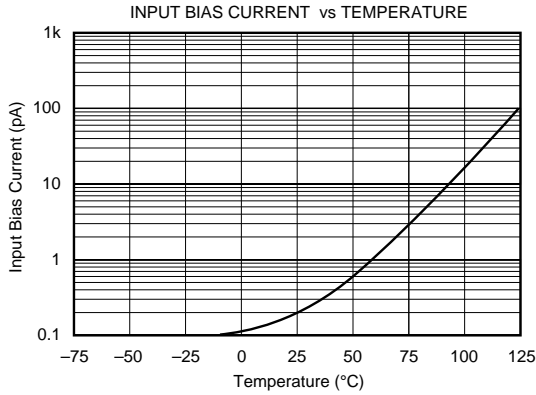

**TYPICAL PERFORMANCE CURVES (CONT)**

At  $T_A = +25^\circ\text{C}$ ,  $V_S = +5\text{V}$ , and  $R_L = 10\text{k}\Omega$  connected to  $V_S/2$ , unless otherwise noted.

SMALL-SIGNAL STEP RESPONSE  
 $C_L = 100\text{pF}$

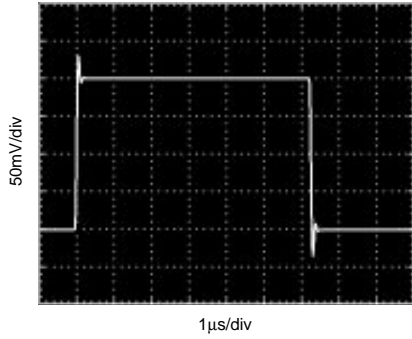

LARGE-SIGNAL STEP RESPONSE  
 $C_L = 100\text{pF}$

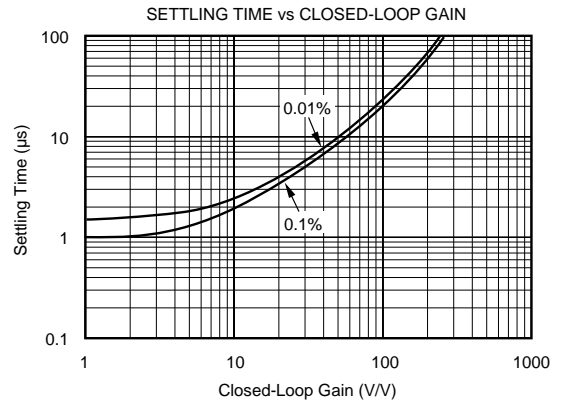
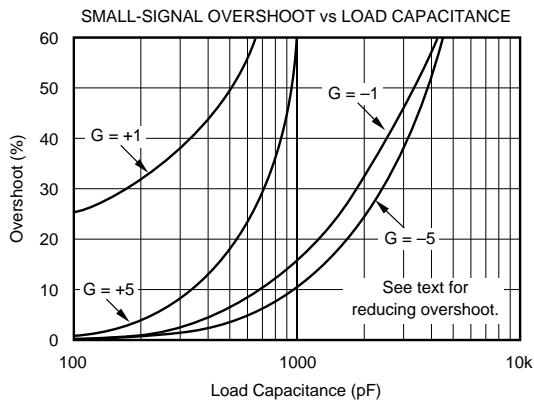
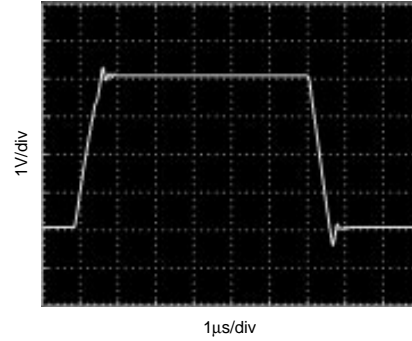

## APPLICATIONS INFORMATION

OPA340 series op amps are fabricated on a state-of-the-art 0.6 micron CMOS process. They are unity-gain stable and suitable for a wide range of general purpose applications. Rail-to-rail input/output make them ideal for driving sampling A/D converters. In addition, excellent ac performance makes them well-suited for audio applications. The class AB output stage is capable of driving 600Ω loads connected to any point between V+ and ground.

Rail-to-rail input and output swing significantly increases dynamic range, especially in low supply applications. Figure 1 shows the input and output waveforms for the OPA340 in unity-gain configuration. Operation is from a single +5V supply with a 10kΩ load connected to V<sub>S</sub>/2. The input is a 5Vp-p sinusoid. Output voltage is approximately 4.98Vp-p.

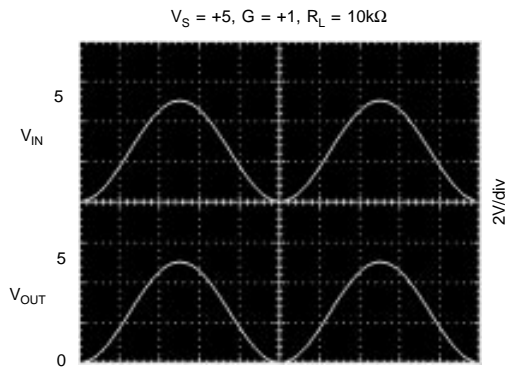

FIGURE 1. Rail-to-Rail Input and Output.

Power supply pins should be bypassed with 0.01μF ceramic capacitors.

### OPERATING VOLTAGE

OPA340 series op amps are fully specified from +2.7V to +5V. However, supply voltage may range from +2.5V to +5.5V. Parameters are guaranteed over the specified supply range—a unique feature of the OPA340 series. In addition, many specifications apply from -40°C to +85°C. Most behavior remains virtually unchanged throughout the full operating voltage range. Parameters which vary significantly with operating voltages or temperature are shown in the typical performance curves.

### RAIL-TO-RAIL INPUT

The input common-mode voltage range of the OPA340 series extends 500mV beyond the supply rails. This is achieved with a complementary input stage—an N-channel input differential pair in parallel with a P-channel differential pair (see Figure 2). The N-channel pair is active for input voltages close to the positive rail, typically (V+) -1.3V to 500mV above the positive supply, while the P-channel pair is on for inputs from 500mV below the negative supply to approximately (V+) -1.3V. There is a small transition region, typically (V+) -1.5V to (V+) -1.1V, in which both pairs are on. This 400mV transition region can vary ±300mV with process variation. Thus, the transition region (both stages on) can range from (V+) -1.8V to (V+) -1.4V on the low end, up to (V+) -1.2V to (V+) -0.8V on the high end.

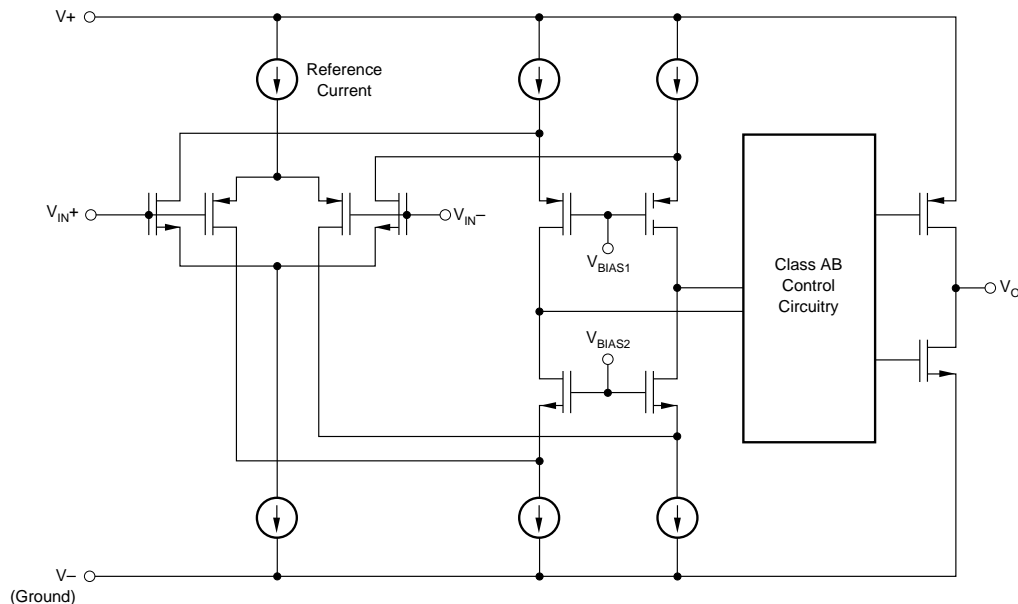

FIGURE 2. Simplified Schematic.



OPA340 series op amps are laser-trimmed to reduce the offset voltage difference between the N-channel and P-channel input stages, resulting in improved common-mode rejection and a smooth transition between the N-channel pair and the P-channel pair. However, within the 400mV transition region PSRR, CMRR, offset voltage, offset drift, and THD may be degraded compared to operation outside this region.

A double-folded cascode adds the signal from the two input pairs and presents a differential signal to the class AB output stage. Normally, input bias current is approximately 200fA, however, input voltages exceeding the power supplies by more than 500mV can cause excessive current to flow in or out of the input pins. Momentary voltages greater than 500mV beyond the power supply can be tolerated if the current on the input pins is limited to 10mA. This is easily accomplished with an input resistor as shown in Figure 3. Many input signals are inherently current-limited to less than 10mA, therefore, a limiting resistor is not required.

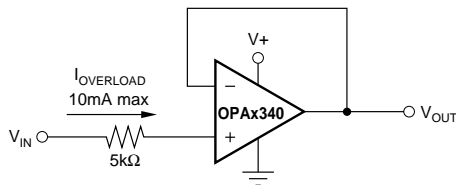

FIGURE 3. Input Current Protection for Voltages Exceeding the Supply Voltage.

### RAIL-TO-RAIL OUTPUT

A class AB output stage with common-source transistors is used to achieve rail-to-rail output. For light resistive loads (>50kΩ), the output voltage is typically a few millivolts from the supply rails. With moderate resistive loads (2kΩ to 50kΩ), the output can swing to within a few tens of millivolts from the supply rails and maintain high open-loop gain. See the typical performance curve “Output Voltage Swing vs Output Current.”

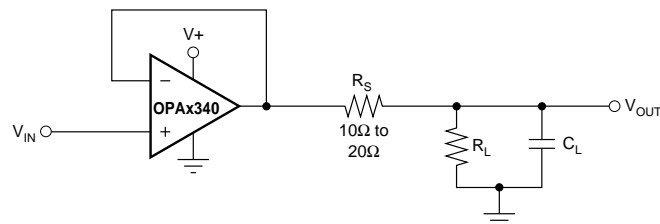

FIGURE 4. Series Resistor in Unity-Gain Configuration Improves Capacitive Load Drive.

### CAPACITIVE LOAD AND STABILITY

OPA340 series op amps can drive a wide range of capacitive loads. However, all op amps under certain conditions may become unstable. Op amp configuration, gain, and load value are just a few of the factors to consider when determining stability. An op amp in unity gain configuration is the most susceptible to the effects of capacitive load. The capacitive load reacts with the op amp’s output resistance, along with any additional load resistance, to create a pole in the small-signal response which degrades the phase margin. In unity gain, OPA340 series op amps perform well, with a pure capacitive load up to approximately 1000pF. Increasing gain enhances the amplifier’s ability to drive more capacitance. See the typical performance curve “Small-Signal Overshoot vs Capacitive Load.”

One method of improving capacitive load drive in the unity gain configuration is to insert a 10Ω to 20Ω resistor in series with the output, as shown in Figure 4. This significantly reduces ringing with large capacitive loads. However, if there is a resistive load in parallel with the capacitive load, it creates a voltage divider introducing a dc error at the output and slightly reduces output swing. This error may be insignificant. For instance, with  $R_L = 10k\Omega$  and  $R_S = 20\Omega$ , there is only about a 0.2% error at the output.

### DRIVING A/D CONVERTERS

OPA340 series op amps are optimized for driving medium speed (up to 100kHz) sampling A/D converters. However, they also offer excellent performance for higher speed converters. The OPA340 series provides an effective means of buffering the A/D’s input capacitance and resulting charge injection while providing signal gain.

Figures 5 and 6 show the OPA340 driving an ADS7816. The ADS7816 is a 12-bit, micro-power sampling converter in the tiny MSOP-8 package. When used with the miniature package options of the OPA340 series, the combination is ideal for space-limited and low power applications. For further information consult the ADS7816 data sheet.

With the OPA340 in a noninverting configuration, an RC network at the amplifier’s output can be used to filter high frequency noise in the signal (Figure 5). In the inverting configuration, filtering may be accomplished with a capacitor across the feedback resistor (Figure 6).

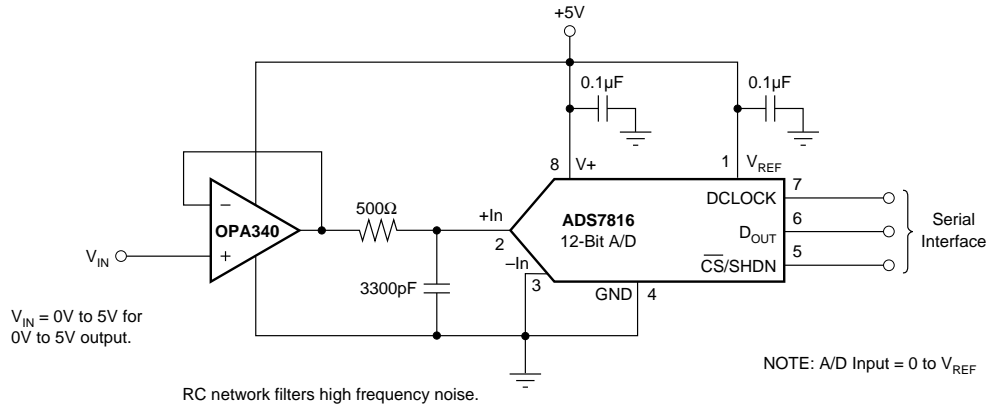

FIGURE 5. OPA340 in Noninverting Configuration Driving ADS7816.

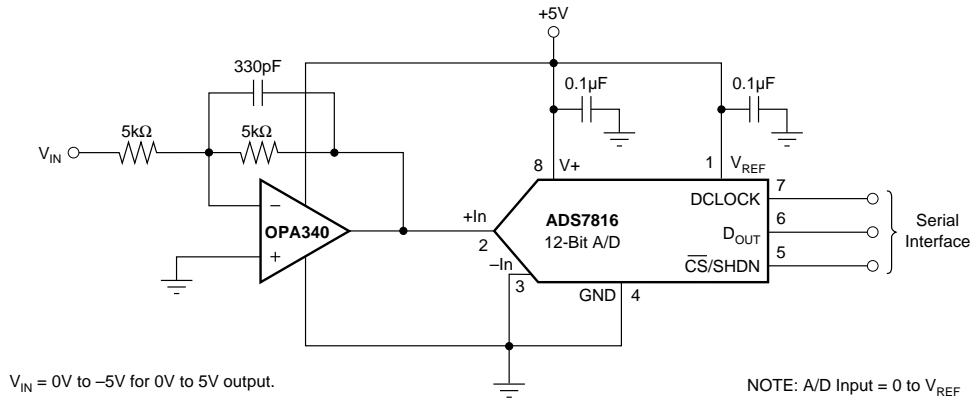

FIGURE 6. OPA340 in Inverting Configuration Driving ADS7816.

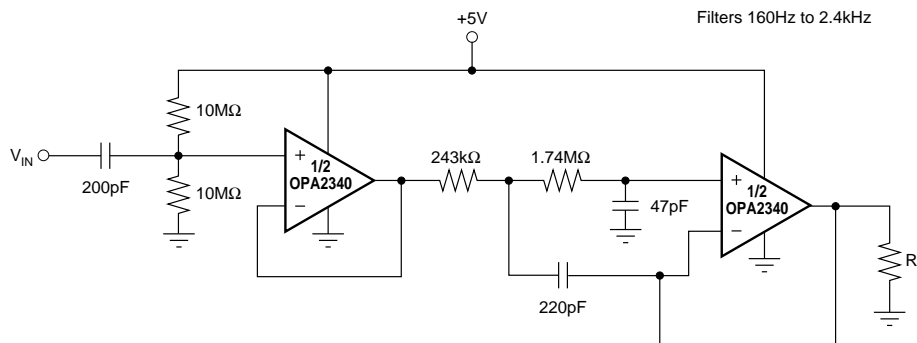

FIGURE 7. Speech Bandpass Filter.

Important statement:

Huaguan Semiconductor Co,Ltd. reserves the right to change the products and services provided without notice. Customers should obtain the latest relevant information before ordering, and verify the timeliness and accuracy of this information.

Customers are responsible for complying with safety standards and taking safety measures when using our products for system design and machine manufacturing to avoid potential risks that may result in personal injury or property damage.

Our products are not licensed for applications in life support, military, aerospace, etc., so we do not bear the consequences of the application of these products in these fields.

Our documentation is only permitted to be copied without any tampering with the content, so we do not accept any responsibility or liability for the altered documents.