

Description

The ASDXXC is designed to replace multilayer varistors (MLVs) in portable applications such as cell phones, notebook computers and PDA's, using monolithic silicon technology to provide fast response time and ultra low ESD clamping voltage, making this device an ideal solution for protecting sensitive semiconductor components from damage. The ASDXXC complies with the IEC 61000-4-2 (ESD) with $\pm 30\text{kV}$ air and $\pm 30\text{kV}$ contact discharge. The ASDXXC is assembled into a lead-free SOD-323 package and will protect one unidirectional line. These devices will fit on the same PCB pad area as an 0805 MLV device.

Features

- 500W peak pulse power (8/20 μs)
- Protects one data or power line
- Ultra low leakage: nA level
- Operating voltage: 3.3V, 5V, 8V, 12V, 15V, 24V, 36V, 40V
- Ultra low clamping voltage
- Complies with following standards:
 - IEC 61000-4-2 (ESD) immunity test
 - Air discharge: $\pm 30\text{kV}$
 - Contact discharge: $\pm 30\text{kV}$
- RoHS Compliant

Dimensions and Pin Configuration

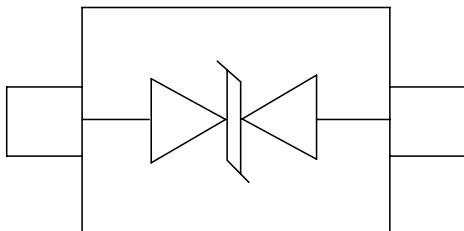

SOD-323

Mechanical Characteristics

- Package: SOD-323
- Lead Finish: Matte Tin
- Case Material: "Green" Molding Compound.
- Moisture Sensitivity: Level 3 per J-STD-020
- Terminal Connections: See Diagram Below
- Marking Information: See Below

Applications

- Cellular Handsets and Accessories
- Personal Digital Assistants
- Notebooks and Handhelds
- Portable Instrumentation
- Peripherals
- Pagers Peripherals
- Desktop and Servers

Marking Information

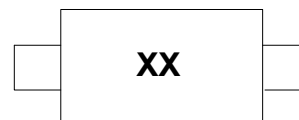

Part Number	Marking
ASD33C	33
ASD05C	05
ASD08C	08
ASD12C	12
ASD15C	15
ASD18C	18
ASD24C	24
ASD36C	36
ASD40C	40

Ordering Information

Part Number	Packaging	Reel Size
ASDXXC	3000/Tape & Reel	7 inch

Absolute Maximum Ratings ($T_A=25^\circ\text{C}$ unless otherwise specified)

Parameter	Symbol	Value	Unit
Peak Pulse Power (8/20 μs)	Ppk	500	W
ESD per IEC 61000-4-2 (Air)	VESD	± 30	kV
ESD per IEC 61000-4-2 (Contact)		± 30	
Operating Temperature Range	TJ	-55 to +125	$^\circ\text{C}$
Storage Temperature Range	Tstg	-55 to +150	$^\circ\text{C}$

Electrical Characteristics ($T_A=25^\circ\text{C}$ unless otherwise specified)

ASD33C						
Parameter	Symbol	Min	Typ	Max	Unit	Test Condition
Reverse Working Voltage	VRWM			3.3	V	
Breakdown Voltage	VBR	3.8			V	IT = 1mA
Reverse Leakage Current	IR			0.2	μA	VRWM = 3.3V
Clamping Voltage	VC			5	V	I _{PP} = 1A (8 x 20 μs pulse)
Clamping Voltage	VC			12.5	V	I _{PP} = 40A (8 x 20 μs pulse)
Peak Pulse Current	I _{pp}			40	A	t _p = 8/20 μs
Junction Capacitance	CJ			200	pF	VR = 0V, f = 1MHz

ASD05C						
Parameter	Symbol	Min	Typ	Max	Unit	Test Condition
Reverse Working Voltage	VRWM			5	V	
Breakdown Voltage	VBR	6			V	IT = 1mA
Reverse Leakage Current	IR			0.2	μA	VRWM = 5V
Clamping Voltage	VC			9.5	V	I _{PP} = 5A (8 x 20 μs pulse)
Clamping Voltage	VC			15	V	I _{PP} = 34A (8 x 20 μs pulse)
Peak Pulse Current	I _{pp}			34	A	t _p = 8/20 μs
Junction Capacitance	CJ			200	pF	VR = 0V, f = 1MHz

ASD08C						
Parameter	Symbol	Min	Typ	Max	Unit	Test Condition
Reverse Working Voltage	VRWM			8	V	
Breakdown Voltage	VBR	8.5			V	IT = 1mA
Reverse Leakage Current	IR			0.2	μA	VRWM = 8V
Clamping Voltage	VC			10	V	I _{PP} = 1A (8 x 20μs pulse)
Clamping Voltage	VC			14	V	I _{PP} = 36A (8 x 20μs pulse)
Peak Pulse Current	I _{pp}			36	A	t _p = 8/20μs
Junction Capacitance	C _J			120	pF	VR = 0V, f = 1MHz

ASD12C						
Parameter	Symbol	Min	Typ	Max	Unit	Test Condition
Reverse Working Voltage	VRWM			12	V	
Breakdown Voltage	VBR	13.3			V	IT = 1mA
Reverse Leakage Current	IR			0.2	μA	VRWM = 12V
Clamping Voltage	VC			19	V	I _{PP} = 5A (8 x 20μs pulse)
Clamping Voltage	VC			28	V	I _{PP} = 18A (8 x 20μs pulse)
Peak Pulse Current	I _{pp}			18	A	t _p = 8/20μs
Junction Capacitance	C _J			100	pF	VR = 0V, f = 1MHz

ASD15C

Parameter	Symbol	Min	Typ	Max	Unit	Test Condition
Reverse Working Voltage	VRWM			15	V	
Breakdown Voltage	VBR	16.7			V	IT = 1mA
Reverse Leakage Current	IR			0.2	µA	VRWM = 15V
Clamping Voltage	VC			18	V	I _{PP} = 1A (8 x 20µs pulse)
Clamping Voltage	VC			25	V	I _{PP} = 16A (8 x 20µs pulse)
Peak Pulse Current	I _{pp}			16	A	t _p = 8/20µs
Junction Capacitance	C _J			80	pF	VR = 0V, f = 1MHz

ASD18C

Parameter	Symbol	Min	Typ	Max	Unit	Test Condition
Reverse Working Voltage	VRWM			18	V	
Breakdown Voltage	VBR	19.8			V	IT = 1mA
Reverse Leakage Current	IR			0.2	µA	VRWM = 15V
Clamping Voltage	VC			25	V	I _{PP} = 1A (8 x 20µs pulse)
Clamping Voltage	VC			38	V	I _{PP} = 13A (8 x 20µs pulse)
Peak Pulse Current	I _{pp}			13	A	t _p = 8/20µs
Junction Capacitance	C _J			60	pF	VR = 0V, f = 1MHz

ASD24C

Parameter	Symbol	Min	Typ	Max	Unit	Test Condition
Reverse Working Voltage	VRWM			24	V	
Breakdown Voltage	VBR	27			V	IT = 1mA
Reverse Leakage Current	IR			0.2	µA	VRWM = 24V
Clamping Voltage	VC			40	V	I _{PP} = 1A (8 x 20µs pulse)
Clamping Voltage	VC			50	V	I _{PP} = 10A (8 x 20µs pulse)
Peak Pulse Current	I _{pp}			8	A	t _p = 8/20µs
Junction Capacitance	C _J			50	pF	VR = 0V, f = 1MHz

ASD36C						
Parameter	Symbol	Min	Typ	Max	Unit	Test Condition
Reverse Working Voltage	VRWM			36	V	
Breakdown Voltage	VBR	38			V	IT = 1mA
Reverse Leakage Current	IR			0.2	μA	VRWM = 36V
Clamping Voltage	VC			40	V	I _{PP} = 1A (8 x 20μs pulse)
Peak Pulse Current	I _{pp}			6	A	t _p = 8/20μs
Junction Capacitance	C _J			30	pF	VR = 0V, f = 1MHz

ASD40C						
Parameter	Symbol	Min	Typ	Max	Unit	Test Condition
Reverse Working Voltage	VRWM			40	V	
Breakdown Voltage	VBR	44			V	IT = 1mA
Reverse Leakage Current	IR			0.2	μA	VRWM = 40V
Clamping Voltage	VC			50	V	I _{PP} = 1A (8 x 20μs pulse)
Peak Pulse Current	I _{pp}			5	A	t _p = 8/20μs
Junction Capacitance	C _J			20	pF	VR = 0V, f = 1MHz

Typical Performance Characteristics ($T_A=25^\circ\text{C}$ unless otherwise Specified)

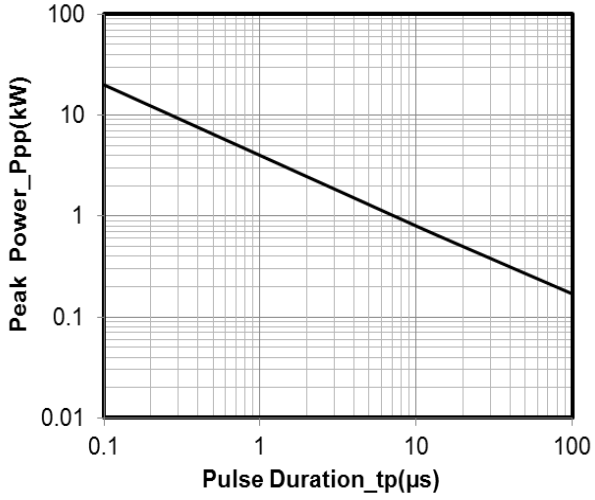

Peak Pulse Power vs. Pulse Time

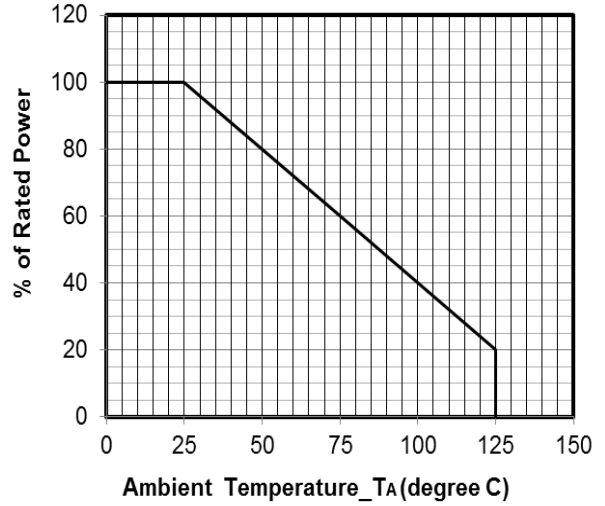

Power Derating Curve

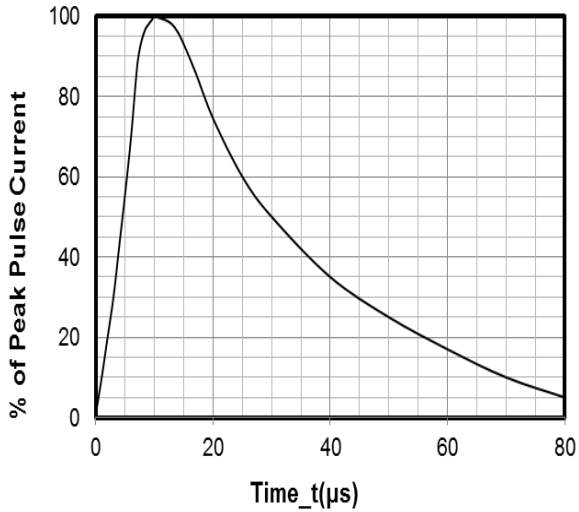

8 X 20μs Pulse Waveform

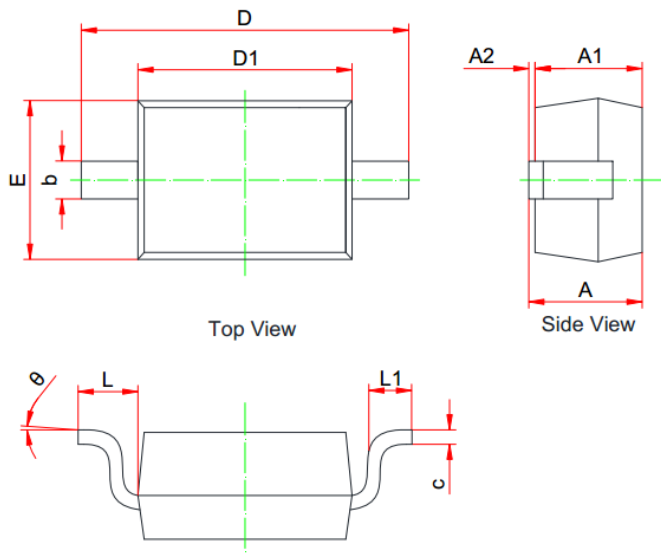
SOD-323 Package Outline Drawing

SYM	MILLIMETERS		
	MIN	NOM	MAX
A	0.800	--	1.100
A1	0.800	--	0.900
A2	0.000	--	0.100
b	0.250	--	0.400
c	0.080	--	0.177
D1	1.600	1.700	1.800
D	2.300	--	2.800
E	1.150	--	1.400
L	0.475REF		
L1	0.100	--	0.500
Θ	0°	--	8°

Suggested Land Pattern

Unit: mm
Contact Information

Applied Power Microelectronics Co., Ltd.

 Website: <http://www.appliedpowermicro.com>

 Email: sales@appliedpowermicro.com

Phone: +86 (0519) 8399 3606