

## WS7803F

<http://www.sh-willsemi.com>

### 0.1GHz – 3GHz SP3T Antenna Switch

#### Descriptions

The WS7803F is a single-pole, three-throw (SP3T) switch. The device is optimized for 3G/4G routing and diversity applications. The high linearity performance and low insertion loss make the device an ideal choice for WCDMA/LTE handset and data card applications. The WS7803F is provided in a compact Quad Flat No-lead Package (QFN) 1.1 x 1.1 mm<sup>2</sup> package.

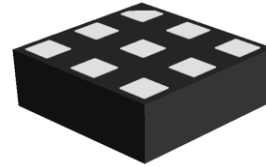

**QFN 1.15X1.15-9L (Bottom view)**

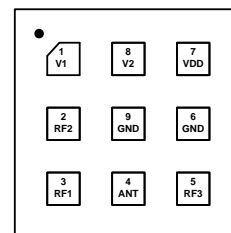

**Pin configuration (Top view)**

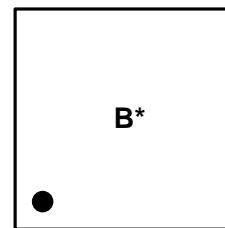

B = Device code  
\* = Month code (A~Z)

**Marking(Top view)**

#### Features

- Small, low profile package 1.1mm x 1.1mm x 0.55mm
- Working frequency up to 3GHz
- Very low insertion loss
- Excellent isolation performance
- Low power consumption
- Exceptional linearity performance for WCDMA/LTE application
- Low harmonic generation
- Very good ESD performance

#### Applications

- Cell phones
- Tablets
- Other RF front-end modules

#### Order information

Device	Package	Shipping
WS7803F-9/TR	QFN 1.1X1.1-9L	3000/Reel&Tape

**Pinning information**

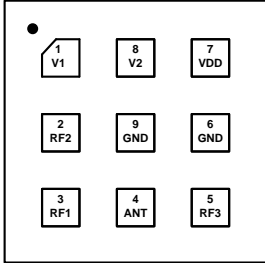
Pin	Function	Description	Transparent top view
1	V1	DC control voltage 1	
2	RF2	RF port 2	
3	RF1	RF port 1	
4	ANT	RF common (antenna) port	
5	RF3	RF port 3	
6	GND	Ground	
7	VDD	DC power supply	
8	V2	DC control voltage 2	
9	GND	Ground	

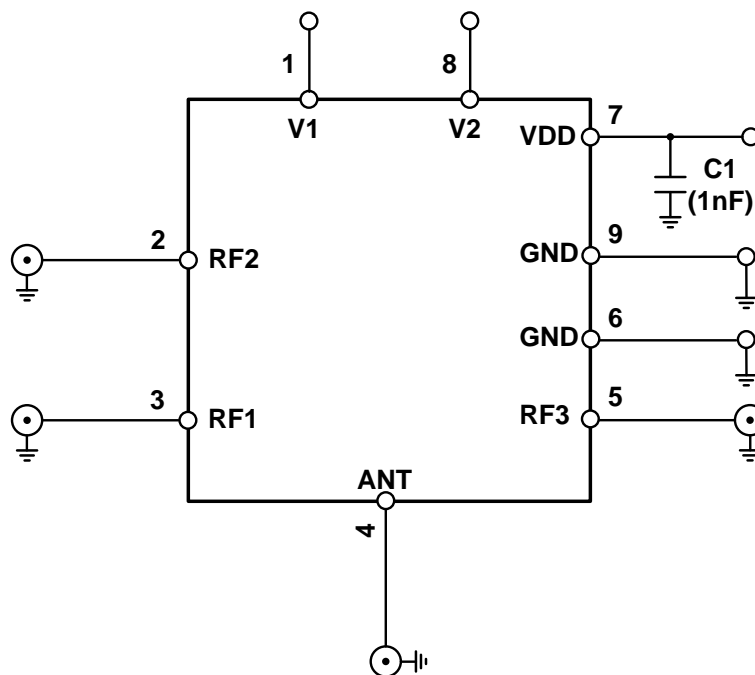
**Application information**

**Recommended operating conditions**

Parameters	Conditions	Specifications			Unit
		Min.	Typ.	Max.	
<b>ESD Rating</b>					
ESD All Pins	HBM, JESD22-A114			1500	V
<b>Power Supply</b>					
Power Supply Voltage	Operating Voltage	2.4	2.8	3.0	V
Power Supply Current	VDD≤3.0V	20	28	40	μA
<b>Control Voltage</b>					
Logic Control "Low"		0	0	0.3	V
Logic Control "High"		1.2	1.8	2.7	V
<b>RF Impedance</b>					
RF Port Input and Output Impedance			50		Ω

**Absolute maximum ratings**

Maximum ratings are absolute ratings, exceeding only one of these values may cause irreversible damage to the integrated circuit.

Items	Value	Unit
VDD Voltage	-0.3 to +3.0	V
Control Voltage	-0.3 to +2.7	V
Maximum Input Power @ RF ports 50Ω, CW, +25°C	29@0.7GHz to 1.0GHz 30@1.0GHz to 2.0GHz 31@2.0GHz to 2.7GHz	dBm
Operation Temperature	-40 to +85	°C
Storage Temperature	-65 to +150	°C

**Characteristics (RF spec)**

Normal test condition unless otherwise stated. All unused ports are 50Ω terminated.

VDD=2.8V, Temp=+25°C. P<sub>IN</sub>=0dBm.

Parameters	Conditions	Specifications			Unit
		Min.	Typ.	Max.	
Insertion Loss (RF1/RF2/RF3)	0.1GHz to 1.0GHz		0.40	0.55	dB
	1.0GHz to 2.0GHz		0.45	0.60	
	2.0GHz to 2.7GHz		0.50	0.65	
Isolation (ANT to RF1/RF2/RF3)	0.1GHz to 1.0GHz	30	33		dB
	1.0GHz to 2.0GHz	25	28		
	2.0GHz to 2.7GHz	21	24		
Input Return Loss (ANT to RF1/RF2/RF3)	0.1GHz to 1.0GHz	25	28		dB
	1.0GHz to 2.0GHz	19	22		
	2.0GHz to 2.7GHz	18	23		
Second Harmonics (RF1/RF2/RF3)	0.7GHz to 1.0GHz, P <sub>IN</sub> =+26dBm		82		dBc
	1.0GHz to 2.0GHz, P <sub>IN</sub> =+26dBm		84		
	2.0GHz to 2.7GHz, P <sub>IN</sub> =+26dBm		85		
Third Harmonics (RF1/RF2/RF3)	0.7GHz to 1.0GHz, P <sub>IN</sub> =+26dBm		72		dBc
	1.0GHz to 2.0GHz, P <sub>IN</sub> =+26dBm		75		
	2.0GHz to 2.7GHz, P <sub>IN</sub> =+26dBm		76		
0.1dB Compression Point (RF1/RF2/RF3)	0.7GHz to 1.0GHz		29		dBm
	1.0GHz to 2.0GHz		30		
	2.0GHz to 2.7GHz		31		
3 <sup>rd</sup> Order Input Intercept Point (RF1/RF2/RF3)	0.7GHz to 2.7GHz P <sub>IN</sub> =+26dBm Δf=1MHz		55		dBm

**Truth Table for Operation**

Mode	V1	V2
RF1	1	0
RF2	1	1
RF3	0	1

Note: Any state other than that described in this Table places the switch into an undefined state. An undefined state will not damage the device.

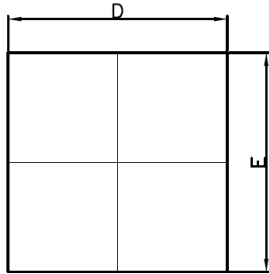
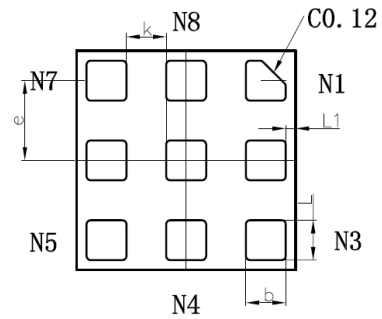
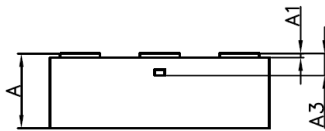
**Package outline dimensions**
**QFN1.1X1.1-9L**

**TOP VIEW**

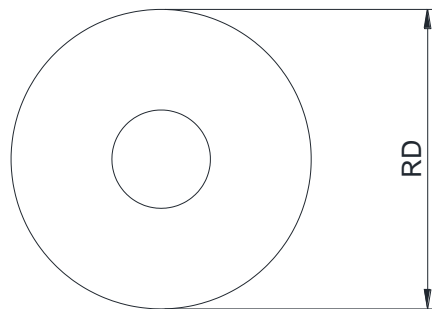
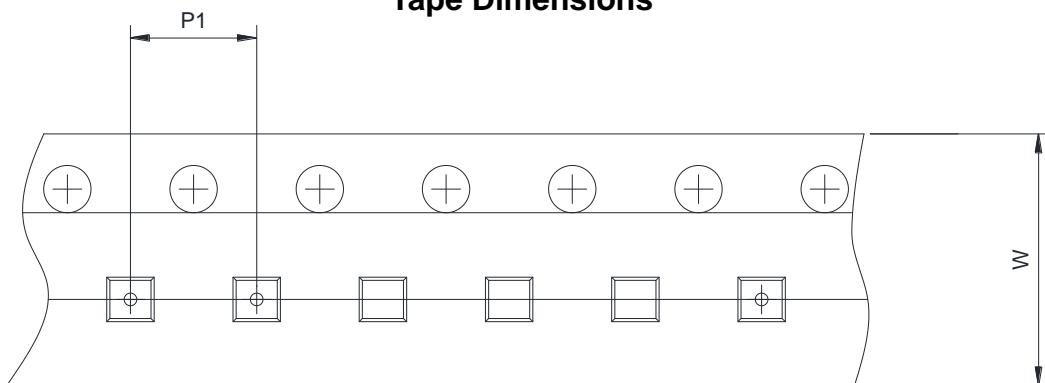
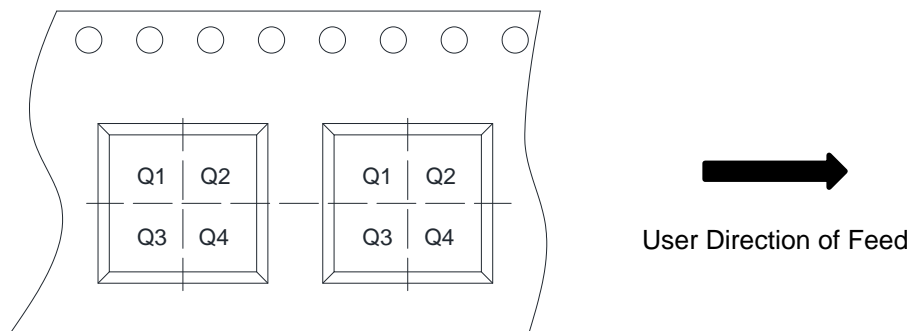
**BOTTOM VIEW**

**SIDE VIEW**

Symbol	Dimensions In Millimeters		Dimensions In Inches	
	Min.	Max.	Min.	Max.
A	0.500	0.600	0.020	0.024
A1	-0.004	0.046	0.000	0.002
A3	0.110REF.		0.004REF.	
D	1.000	1.200	0.039	0.047
E	1.000	1.200	0.039	0.047
k	0.200REF.		0.008REF.	
b	0.150	0.250	0.006	0.010
e	0.400BSC.		0.016BSC.	
L	0.150	0.250	0.006	0.010
L1	0.050REF.		0.002REF.	

**Tape and reel information**
**Reel Dimensions**

**Tape Dimensions**

**Quadrant Assignments For PIN1 Orientation In Tape**

RD	Reel Dimension	<input checked="" type="checkbox"/> 7inch	<input type="checkbox"/> 13inch		
W	Overall width of the carrier tape	<input checked="" type="checkbox"/> 8mm	<input type="checkbox"/> 12mm		
P1	Pitch between successive cavity centers	<input type="checkbox"/> 2mm	<input checked="" type="checkbox"/> 4mm	<input type="checkbox"/> 8mm	
Pin1	Pin1 Quadrant	<input checked="" type="checkbox"/> Q1	<input type="checkbox"/> Q2	<input type="checkbox"/> Q3	<input type="checkbox"/> Q4