

TLE9251

High Speed CAN FD Transceiver



1 Overview

Features

- Fully compliant to ISO 11898-2 (2016) and SAE J2284-4/-5
- Reference device and part of Interoperability Test Specification for CAN Transceiver
- Guaranteed loop delay symmetry for CAN FD data frames up to 5 MBit/s
- Very low electromagnetic emission (EME) allows the use without additional common mode choke
- Stand-by mode with minimized quiescent current
- Wake-up indication on the RxD output
- Wide common mode range for electromagnetic immunity (EMI)
- Excellent ESD robustness +/-10kV (HBM) and +/-11kV (IEC 61000-4-2)
- Extended supply range on the V_{CC}
- CAN short circuit proof to ground, battery and V_{CC}
- TxD time-out function
- Very low CAN bus leakage current in power-down state
- Overtemperature protection
- Protected against automotive transients according ISO 7637 and SAE J2962-2 standards
- Green Product (RoHS compliant)
- Small, leadless TSON8 package designed for automated optical inspection (AOI)

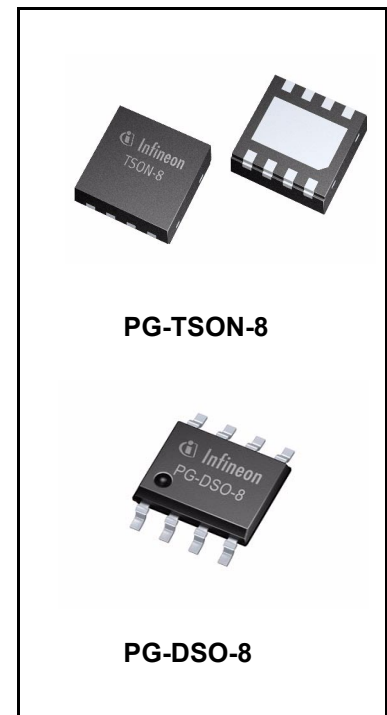

Potential applications

- Gateway Modules
- Body Control Modules (BCM)
- Engine Control Unit (ECUs)

Product validation

Qualified for automotive applications. Product validation according to AEC-Q100.

Overview

Description

Type	Package	Marking
TLE9251LE	PG-TSON-8	9251
TLE9251SJ	PG-DSO-8	9251

The TLE9251 is the latest Infineon high-speed CAN transceiver generation, used inside HS CAN networks for automotive and also for industrial applications. It is designed to fulfill the requirements of ISO 11898-2 (2016) physical layer specification and respectively also the SAE standards J1939 and J2284.

The TLE9251 is available in a PG-DSO-8 package and in a small, leadless PG-TSON-8 package. Both packages are RoHS compliant and halogen free. The PG-TSON-8 package supports the solder joint requirements for automated optical inspection (AOI).

As an interface between the physical bus layer and the HS CAN protocol controller, the TLE9251 protects the microcontroller against interferences generated inside the network. A very high ESD robustness and the perfect RF immunity allows the use in automotive applications without adding additional protection devices, like suppressor diodes for example.

While the transceiver TLE9251 is not supplied the bus is switched off and illustrates an ideal passive behavior with the lowest possible load to all other subscribers of the HS CAN network.

Based on the high symmetry of the CANH and CANL output signals, the TLE9251 provides a very low level of electromagnetic emission (EME) within a wide frequency range. The TLE9251 fulfills even stringent EMC test limits without additional external circuit, like a common mode choke for example.

The perfect transmitter symmetry combined with the optimized delay symmetry of the receiver enables the TLE9251 to support CAN FD data frames. Depending on the size of the network and the along coming parasitic effects the device supports bit rates up to 5 MBit/s.

Dedicated low-power modes, like Stand-by mode provide very low quiescent currents while the device is powered up. In Stand-by mode the typical quiescent current on V_{CC} is below 10 μ A while the device can still be woken up by a bus signal on the HS CAN bus.

Fail-safe features like overtemperature protection, output current limitation or the TxD time-out feature protect the TLE9251 and the external circuitry from irreparable damage.

Table of contents

1	Overview	1
	Features	1
	Potential applications	1
	Product validation	1
	Description	2
	Table of contents	3
2	Block diagram	4
3	Pin configuration	5
3.1	Pin assignment	5
3.2	Pin definitions	5
4	General product characteristics	6
4.1	Absolute maximum ratings	6
4.2	Functional range	7
4.3	Thermal resistance	7
5	High-speed CAN functional description	8
5.1	High-speed CAN physical layer	8
6	Modes of operation	10
6.1	Normal-operating mode	11
6.2	Stand-by mode	11
6.3	Power-down state	11
7	Changing the mode of operation	12
7.1	Power-up and power-down	12
7.2	Mode change by the STB pin	13
7.3	Remote wake-up	14
8	Fail safe functions	16
8.1	Short circuit protection	16
8.2	Unconnected logic pins	16
8.3	TxD time-out function	16
8.4	Overtemperature protection	16
9	Electrical characteristics	18
9.1	Functional device characteristics	18
9.2	Diagrams	23
10	Application information	24
10.1	ESD robustness according to IEC61000-4-2	24
10.2	Application example	24
10.3	Further application information	25
11	Package outline	26
12	Revision history	27

Block diagram

2 Block diagram

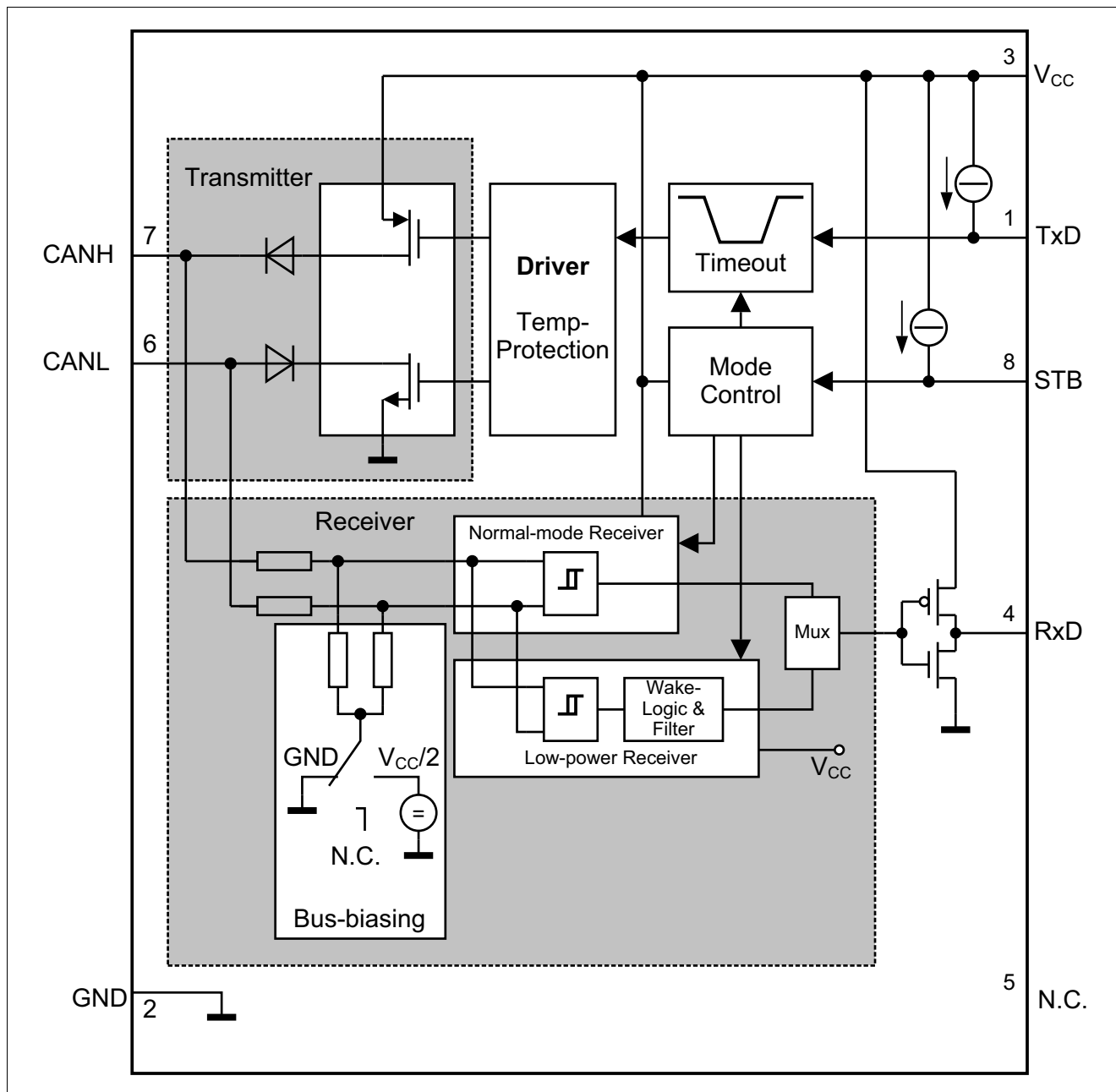

Figure 1 Functional block diagram

Pin configuration

3 Pin configuration

3.1 Pin assignment

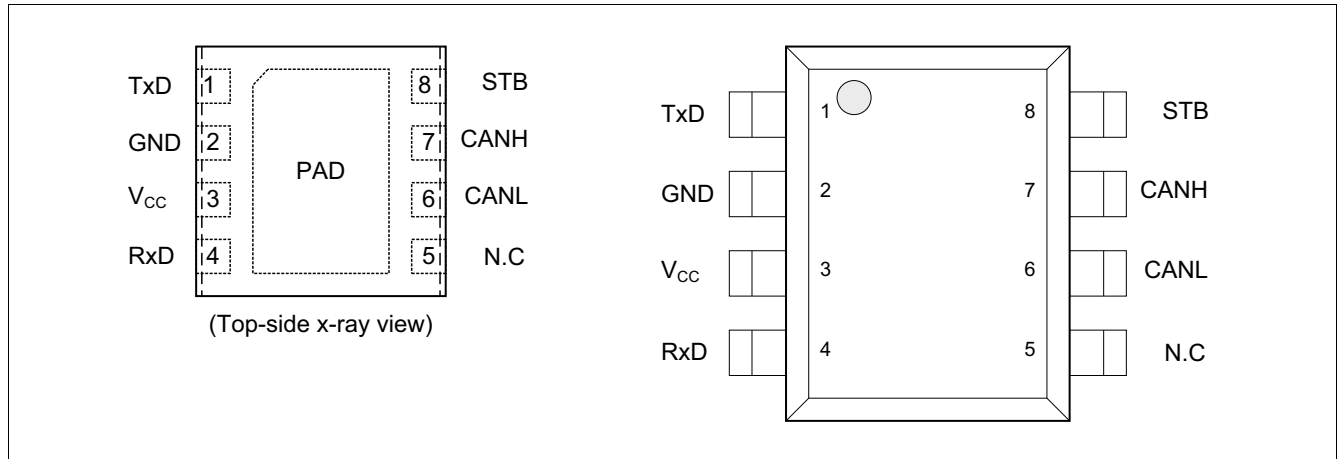

Figure 2 Pin configuration

3.2 Pin definitions

Table 1 Pin definitions and functions

Pin No.	Symbol	Function
1	TxD	Transmit Data Input; Internal pull-up to V_{CC} , “low” for dominant state.
2	GND	Ground
3	V_{CC}	Transmitter Supply Voltage; 100 nF decoupling capacitor to GND required,
4	RxD	Receive Data Output; “low” in dominant state.
5	N.C.	Not Connected; Pin has no function and is internally not connected.
6	CANL	CAN Bus Low Level I/O; “low” in dominant state.
7	CANH	CAN Bus High Level I/O; “high” in dominant state.
8	STB	Stand-by Input; Internal pull-up to V_{CC} , “low” for Normal-operating mode.
PAD	–	Connect to PCB heat sink area. Do not connect to other potential than GND.

General product characteristics

4 General product characteristics

4.1 Absolute maximum ratings

Table 2 Absolute maximum ratings voltages, currents and temperatures¹⁾

All voltages with respect to ground; positive current flowing into pin;
(unless otherwise specified)

Parameter	Symbol	Values			Unit	Note or Test Condition	Number
		Min.	Typ.	Max.			
Voltages							
Transmitter supply voltage	V_{CC}	-0.3	-	6.0	V	-	P_8.1.1
CANH and CANL DC voltage versus GND	V_{CANH}	-40	-	40	V	-	P_8.1.3
Differential voltage between CANH and CANL	V_{CAN_Diff}	-40	-	40	V	-	P_8.1.4
Voltages at the digital I/O pins: STB, RxD, TxD	V_{MAX_IO1}	-0.3	-	6.0	V	-	P_8.1.5
Voltages at the digital I/O pins: STB, RxD, TxD	V_{MAX_IO2}	-0.3	-	$V_{CC} + 0.3$	V	-	P_8.1.6
Currents							
RxD output current	I_{RxD}	-5	-	5	mA	-	P_8.1.7
Temperatures							
Junction temperature	T_j	-40	-	150	°C	-	P_8.1.8
Storage temperature	T_s	-55	-	150	°C	-	P_8.1.9
ESD Resistivity							
ESD immunity at CANH, CANL versus GND	$V_{ESD_HBM_CAN}$	-10	-	10	kV	HBM (100 pF via 1.5 kΩ) ²⁾	P_8.1.11
ESD immunity at all other pins	$V_{ESD_HBM_ALL}$	-2	-	2	kV	HBM (100 pF via 1.5 kΩ) ²⁾	P_8.1.12
ESD immunity all pins	V_{ESD_CDM}	-750	-	750	V	CDM ³⁾	P_8.1.13

1) Not subject to production test, specified by design

2) ESD susceptibility, Human Body Model "HBM" according to ANSI/ESDA/JEDEC JS-001

3) ESD susceptibility, Charge Device Model "CDM" according to EIA/JESD22-C101 or ESDA STM5.3.1

Note: Stresses above the ones listed here may cause permanent damage to the device. Exposure to absolute maximum rating conditions for extended periods may affect device reliability. Integrated protection functions are designed to prevent IC destruction under fault conditions described in the data sheet. Fault conditions are considered as "outside" normal-operating range. Protection functions are not designed for continuous repetitive operation.

General product characteristics

4.2 Functional range

Table 3 Functional range

Parameter	Symbol	Values			Unit	Note or Test Condition	Number
		Min.	Typ.	Max.			
Supply Voltages							
Transmitter supply voltage	V_{CC}	4.5	–	5.5	V	–	P_8.2.1
Thermal Parameters							
Junction temperature	T_j	-40	–	150	°C	1)	P_8.2.3

1) Not subject to production test, specified by design.

Note: Within the functional range the IC operates as described in the circuit description. The electrical characteristics are specified within the conditions given in the related electrical characteristics table.

4.3 Thermal resistance

Note: This thermal data was generated in accordance with JEDEC JESD51 standards. For more information, please visit www.jedec.org.

Table 4 Thermal resistance¹⁾

Parameter	Symbol	Values			Unit	Note or Test Condition	Number
		Min.	Typ.	Max.			
Thermal Resistances							
Junction to Ambient PG-TSON-8	R_{thJA_TSON8}	–	65	–	K/W	2)	P_8.3.1
Junction to Ambient PG-DSO-8	R_{thJA_DSO8}	–	120	–	K/W	2)	P_8.3.2

Thermal Shutdown (junction temperature)

Thermal shutdown temperature, rising	T_{JSD}	170	180	190	°C	temperature falling: Min. 150°C	P_8.3.3
Thermal shutdown hysteresis	ΔT	5	10	20	K	–	P_8.3.4

1) Not subject to production test, specified by design

2) Specified R_{thJA} value is according to Jedec JESD51-2,-7 at natural convection on FR4 2s2p board. The product (TLE9251) was simulated on a 76.2 x 114.3 x 1.5 mm board with 2 inner copper layers (2 x 70µm Cu, 2 x 35µm Cu)

5 High-speed CAN functional description

HS CAN is a serial bus system that connects microcontrollers, sensors and actuators for real-time control applications. The use of the Controller Area Network (abbreviated CAN) within road vehicles is described by the international standard ISO 11898. According to the 7-layer OSI reference model the physical layer of a HS CAN bus system specifies the data transmission from one CAN node to all other available CAN nodes within the network. The physical layer specification of a CAN bus system includes all electrical specifications of a CAN network. The CAN transceiver is part of the physical layer specification. Several different physical layer standards of CAN networks have been developed in recent years. The TLE9251 is a high-speed CAN transceiver with a dedicated bus wake-up function as defined in the latest ISO 11898-2 HS CAN standard.

5.1 High-speed CAN physical layer

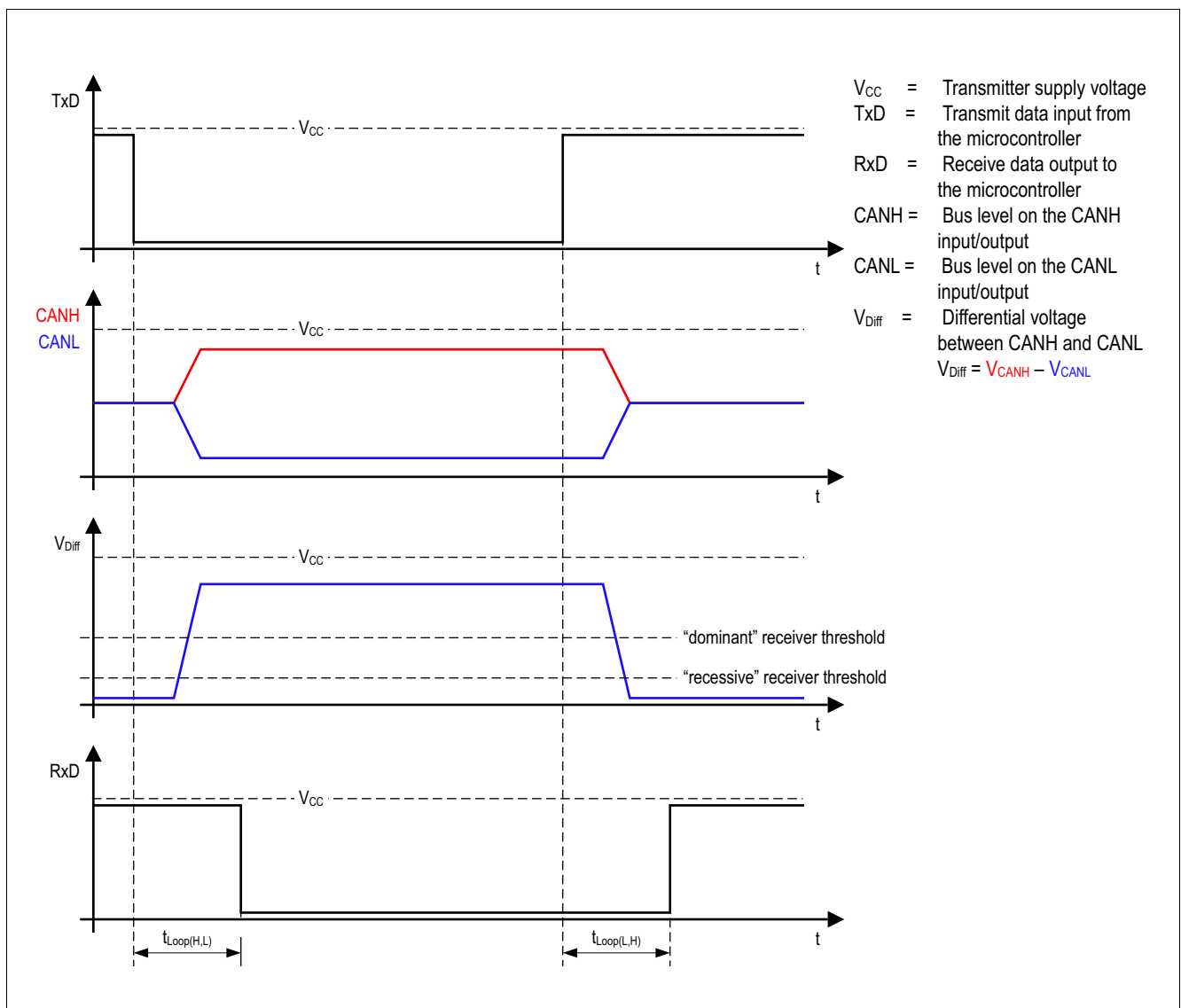

Figure 3 High-speed CAN bus signals and logic signals

High-speed CAN functional description

The TLE9251 is a high-speed CAN transceiver, operating as an interface between the CAN controller and the physical bus medium. A HS CAN network is a two wire, differential network which allows data transmission rates up to 5 MBit/s. The characteristic for a HS CAN network are the two signal states on the CAN bus: dominant and recessive (see [Figure 3](#)).

The CANH and CANL pins are the interface to the CAN bus and both pins operate as an input and output. The RxD and TxD pins are the interface to the microcontroller. The pin TxD is the serial data input from the CAN controller, the RxD pin is the serial data output to the CAN controller. As shown in [Figure 1](#), the HS CAN transceiver TLE9251 includes a receiver and a transmitter unit, allowing the transceiver to send data to the bus medium and monitor the data from the bus medium at the same time. The HS CAN transceiver TLE9251 converts the serial data stream which is available on the transmit data input TxD, into a differential output signal on the CAN bus, provided by the CANH and CANL pins. The receiver stage of the TLE9251 monitors the data on the CAN bus and converts them to a serial, single-ended signal on the RxD output pin. A logical “low” signal on the TxD pin creates a dominant signal on the CAN bus, followed by a logical “low” signal on the RxD pin (see [Figure 3](#)). The feature, broadcasting data to the CAN bus and listening to the data traffic on the CAN bus simultaneously is essential to support the bit-to-bit arbitration within CAN networks.

The voltage levels for HS CAN transceivers are defined in ISO 11898-2. Whether a data bit is dominant or recessive depends on the voltage difference between the CANH and CANL pins:

$$V_{\text{Diff}} = V_{\text{CANH}} - V_{\text{CANL}}$$

To transmit a dominant signal to the CAN bus the amplitude of the differential signal V_{Diff} is higher than or equal to 1.5 V. To receive a recessive signal from the CAN bus the amplitude of the differential V_{Diff} is lower than or equal to 0.5 V.

“Partially-supplied” high-speed CAN networks are those where the CAN bus nodes of one common network have different power supply conditions. Some nodes are connected to the common power supply, while other nodes are disconnected from the power supply and in power-down state. Regardless of whether the CAN bus subscriber is supplied or not, each subscriber connected to the common bus media must not interfere in the communication. The TLE9251 is designed to support “partially-supplied” networks. In power-down state, the receiver input resistors are switched off and the transceiver input has a high resistance.

For permanently supplied ECU's, the HS CAN transceiver TLE9251 provides a Stand-by mode. In Stand-by mode, the power consumption of the TLE9251 is optimized to a minimum, while the device is still able to recognize wake-up patterns on the CAN bus and signal the wake-up event to the external microcontroller.

The voltage level on the digital input TxD and the digital output RxD is determined by the power supply level at the V_{CC} pin. Depending on the voltage level at the V_{CC} pin, the signal levels on the logic pins (STB, TxD and RxD) are compatible with microcontrollers having a 5 V I/O supply.

Modes of operation

6 Modes of operation

The TLE9251 supports three different modes of operation (see [Figure 4](#) and [Table 5](#)):

- Normal-operating mode
- Stand-by mode

Mode changes are either triggered by the mode selection input pin STB . Wake-up events on the HS CAN bus are indicated on the RxD output pin in Stand-by mode, but no mode change is triggered by a wake-up event. An undervoltage event on the supply V_{CC} powers down the TLE9251.

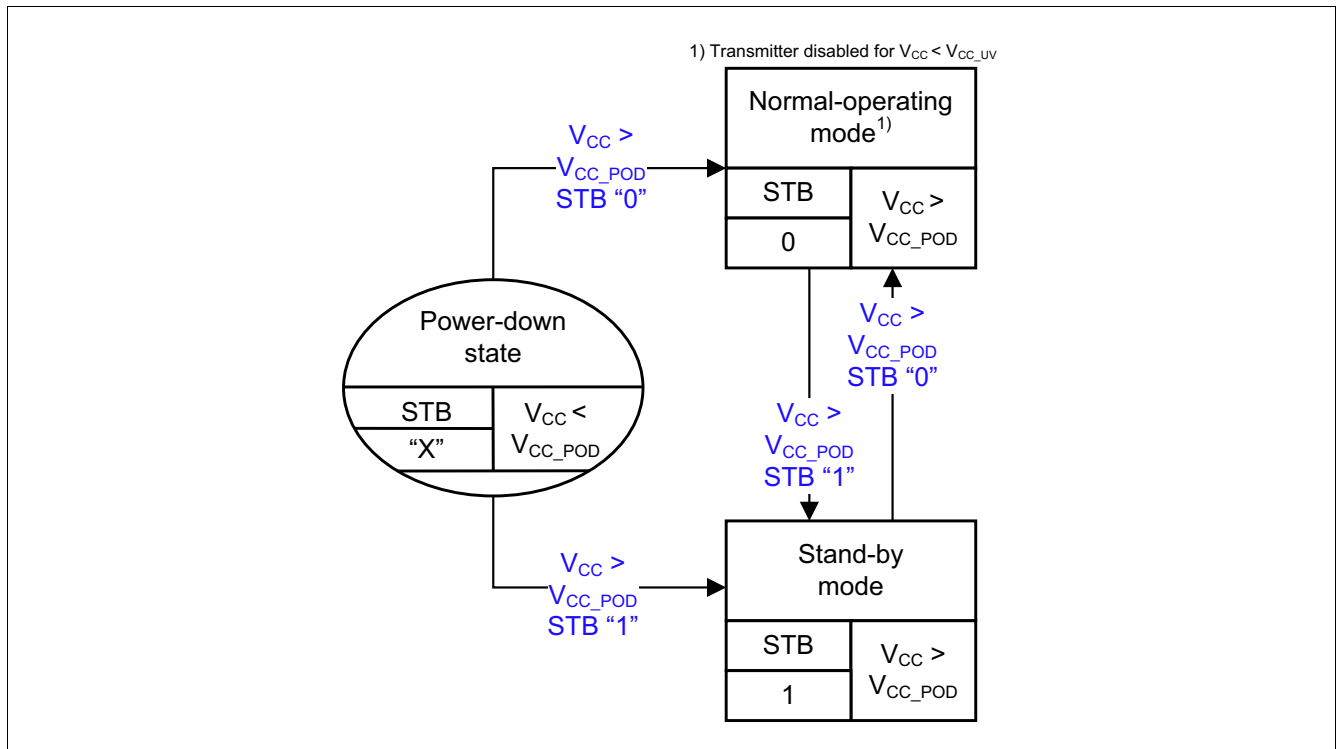

Figure 4 Mode state diagram

Table 5 Modes of operation

Mode	STB	V_{CC}	Bus Bias	Transmitter	Normal-mode Receiver	Low-power Receiver
Normal-operating	"low"	$V_{CC} > V_{CC_UV}$	$V_{CC}/2$	"on"	"on"	"off"
	"low"	$V_{CC_UV} > V_{CC} > V_{CC_POD}$	GND	"off"	"on"	"off"
Stand-by	"high"	$V_{CC} > V_{CC_POD}$	GND	"off"	"off"	"on"
Power-down state	"X"	$V_{CC} < V_{CC_POD}$	floating	"off"	"off"	"off"

Modes of operation

6.1 Normal-operating mode

In Normal-operating mode the transceiver TLE9251 sends and receives data from the HS CAN bus. All functions are active (see also [Figure 4](#) and [Table 5](#)):

- The transmitter is active and drives the serial data stream on the TxD input pin to the bus pins CANH and CANL.
- The normal-mode receiver is active and converts the signals from the bus to a serial data stream on the RxD output.
- The low-power receiver is turned off.
- The RxD output pin indicates the data received by the normal-mode receiver.
- The bus biasing is connected to $V_{CC}/2$.
- The STB input pin is active and changes the mode of operation.
- The TxD time-out function is enabled and disconnects the transmitter in case a time-out is detected.
- The overtemperature protection is enabled and disconnects the transmitter in case an overtemperature is detected.
- The undervoltage detection on V_{CC} is enabled .

Normal-operating mode is entered from Stand-by mode , when the STB input pin is set to logical “low”.

Normal-operating mode can only be entered when all supplies are available:

- The supply V_{CC} is available ($V_{CC} > V_{CC_POD}$).

6.2 Stand-by mode

The Stand-by mode is the power save mode of the TLE9251. In Stand-by mode most of the functions are turned off and the TLE9251 is monitoring the bus for a valid wake-up pattern (WUP). The following functions are available (see also [Figure 4](#) and [Table 5](#)):

- The transmitter is disabled and the data available on the TxD input is blocked.
- The normal-mode receiver is disabled.
- The low-power receiver is turned on and monitors the bus for a valid wake-up pattern (WUP).
- The RxD output pin follows the Bus signal after WUP detection.
- The bus biasing is connected to GND.
- The STB input pin is active and changes the mode of operation.
- The TxD time-out function is disabled.
- The overtemperature protection is disabled.
- The undervoltage detection on V_{CC} is enabled and powers down the device in case of detection.

The Stand-by mode can be entered from Normal-operating mode by setting the STB pin to logical “high”.

To enter Stand-by mode the supply V_{CC} needs to be available ($V_{CC} > V_{CC_POD}$).

6.3 Power-down state

Independent of the status at STB input pin the TLE9251 is powered down if the supply voltage $V_{CC} < V_{CC_POD}$ (see [Figure 4](#)).

In the power-down state the differential input resistors of the receiver are switched off. The CANH and CANL bus interface of the TLE9251 is floating and acts as a high-impedance input with a very small leakage current. The high-ohmic input does not influence the recessive level of the CAN network and allows an optimized EME performance of the entire HS CAN network. In power-down state the transceiver is an invisible node to the bus.

Changing the mode of operation

7 Changing the mode of operation

7.1 Power-up and power-down

The HS CAN transceiver TLE9251 powers up by applying the supply voltage V_{CC} to the device ($V_{CC} > V_{CC_POD}$). After powering up, the device enters one out of two operating modes (see **Figure 5** and **Figure 6**).

Depending on the condition of the mode selection pin STB the device can enter every mode of operation after the power-up:

- V_{CC} is available and STB input is set to “low” - Normal-operating mode

The device TLE9251 powers down when the supply falls below the undervoltage detection threshold. The power-down detection is active in every mode of operation.

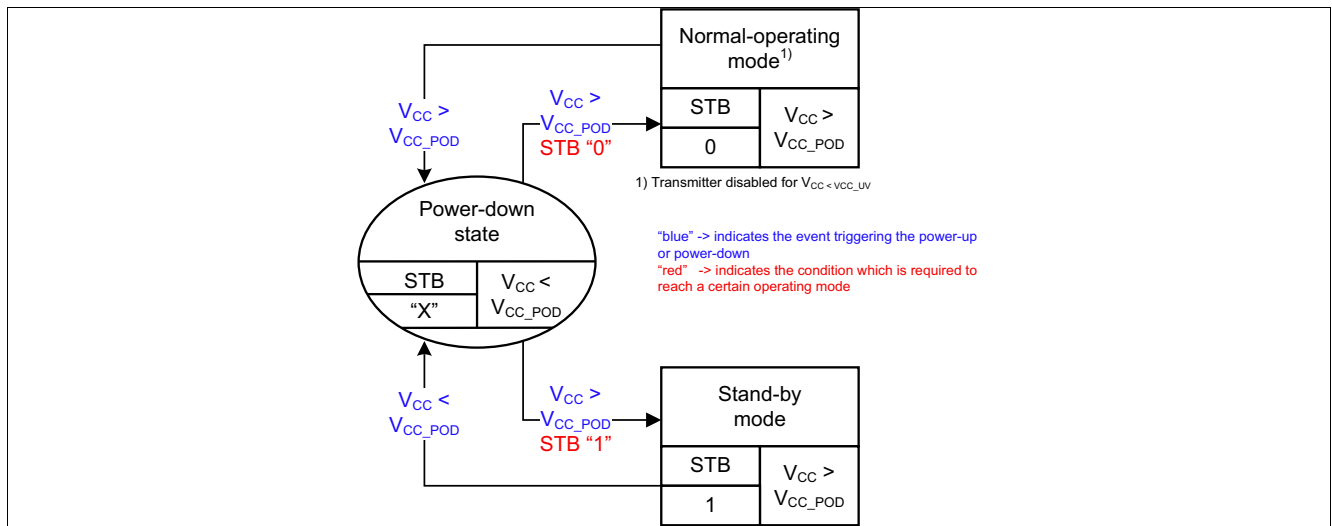

Figure 5 Power-up and power-down

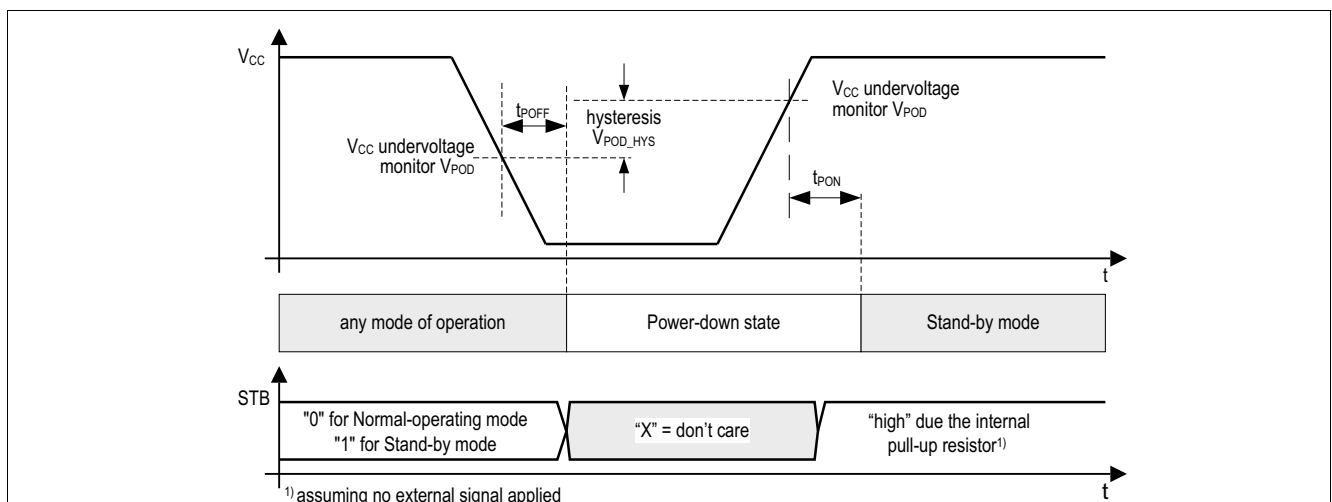

Figure 6 Power-up and power-down timings

Changing the mode of operation

7.2 Mode change by the STB pin

When the TLE9251 is supplied with the voltage V_{CC} the internal logic works and mode change by the mode selection pin STB is possible.

By default the STB input pin is logical “high” due to the internal pull-up current source to V_{CC} . Changing the STB input pin to logical “low” in Stand-by mode triggers a mode change to Normal-operating mode (see **Figure 7**).

Stand-by mode can be entered from Normal-operating mode by setting the STB pin to logical “high”. While changing the mode of operation from Normal-operating mode to Stand-by mode, the transceiver TLE9251 turns off the transmitter.

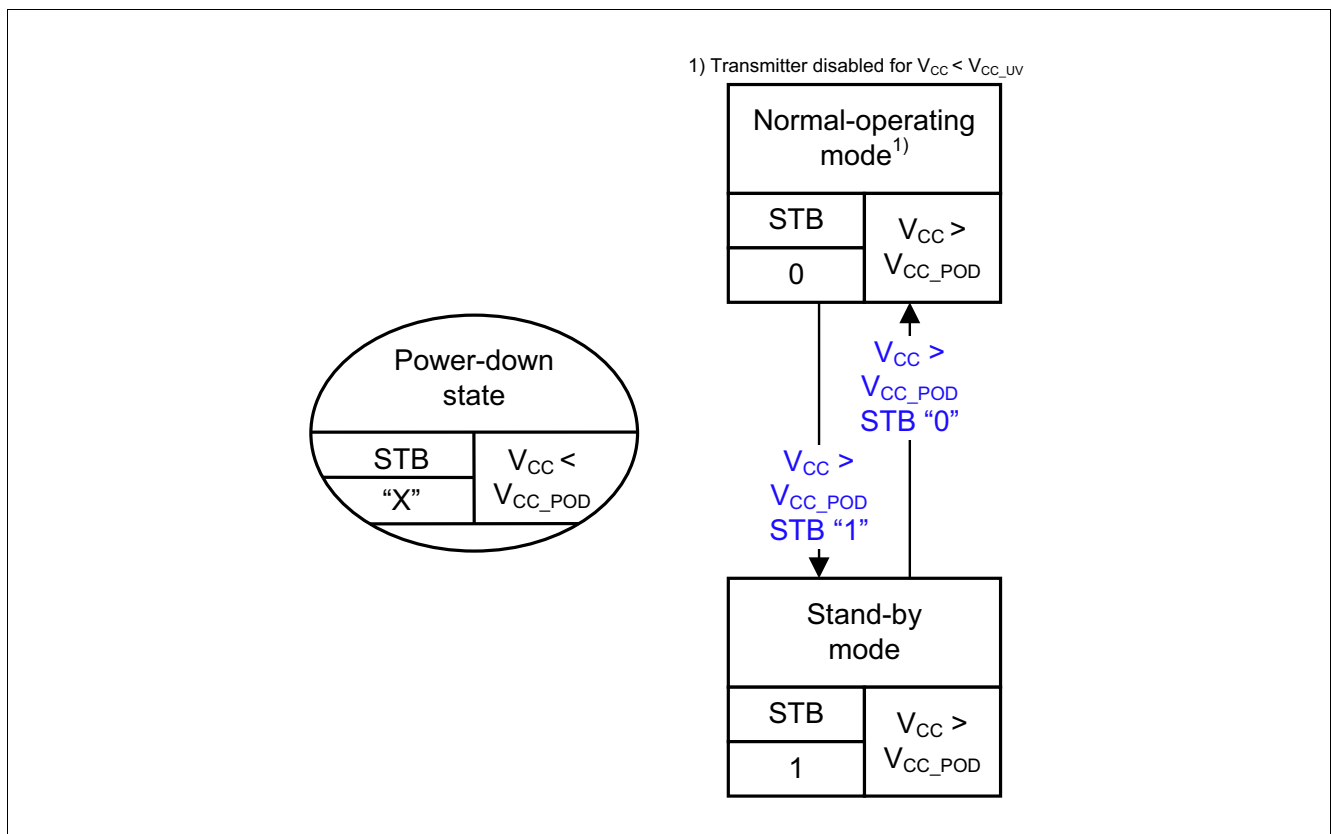

Figure 7 Mode selection by the STB pin

Changing the mode of operation

7.3 Remote wake-up

The TLE9251 has a remote wake-up feature also called bus wake-up feature according to the ISO 11898-2 (2016). In Stand-by mode the low-power receiver monitors the activity on the CAN bus and in case it detects a wake-up pattern it indicates the wake-up signal on the RxD output pin.

In Stand-by mode a wake-up event on the HS CAN is flagged on the RxD output pin (see Figure 9). The transceiver remains in the currently selected mode of operation. No mode change is applied due to the wake-up event (see Figure 8).

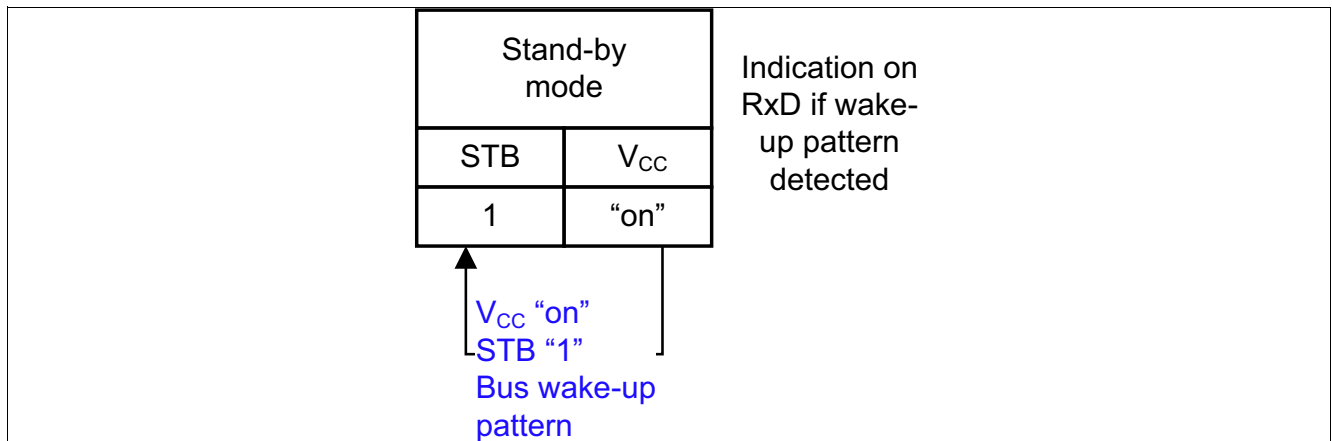

Figure 8 Remote wake-up

A bus wake-up is triggered by a dedicated valid wake-up pattern. The defined wake-up pattern avoids any false wake-up by spikes which might be on the HS CAN bus or by a permanent bus shortage.

The internal wake-up flag will be reset when:

- A mode change to Normal-operating mode is applied during the wake-up pattern.
- A power-down event occurs on the digital supply V_{CC}.

Within the maximum wake-up time t_{WAKE} , the wake-up pattern contents a dominant signal with the pulse width t_{Filter} , followed by a recessive signal with the pulse width t_{Filter} and another dominant signal with the pulse width t_{Filter} (see Figure 9). The RxD output remains logical "high" as long no wake-up event has been detected.

Changing the mode of operation

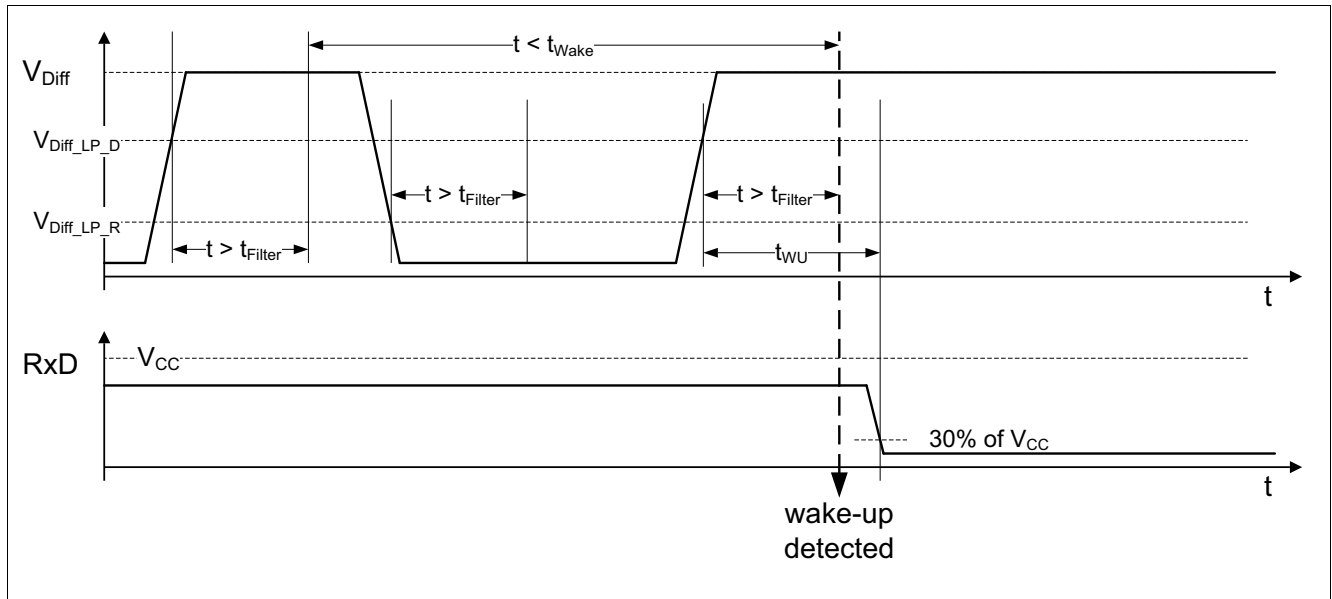

Figure 9 Remote wake-up signal

After a wake-up event has been detected the RxD output follows the CANH/CANL input pins. Dominant and recessive signals are indicated on the RxD output as logical “high” and “low” with the delay of t_{WU} as long their pulse width exceeds the filter time t_{Filter} (see also Figure 10).

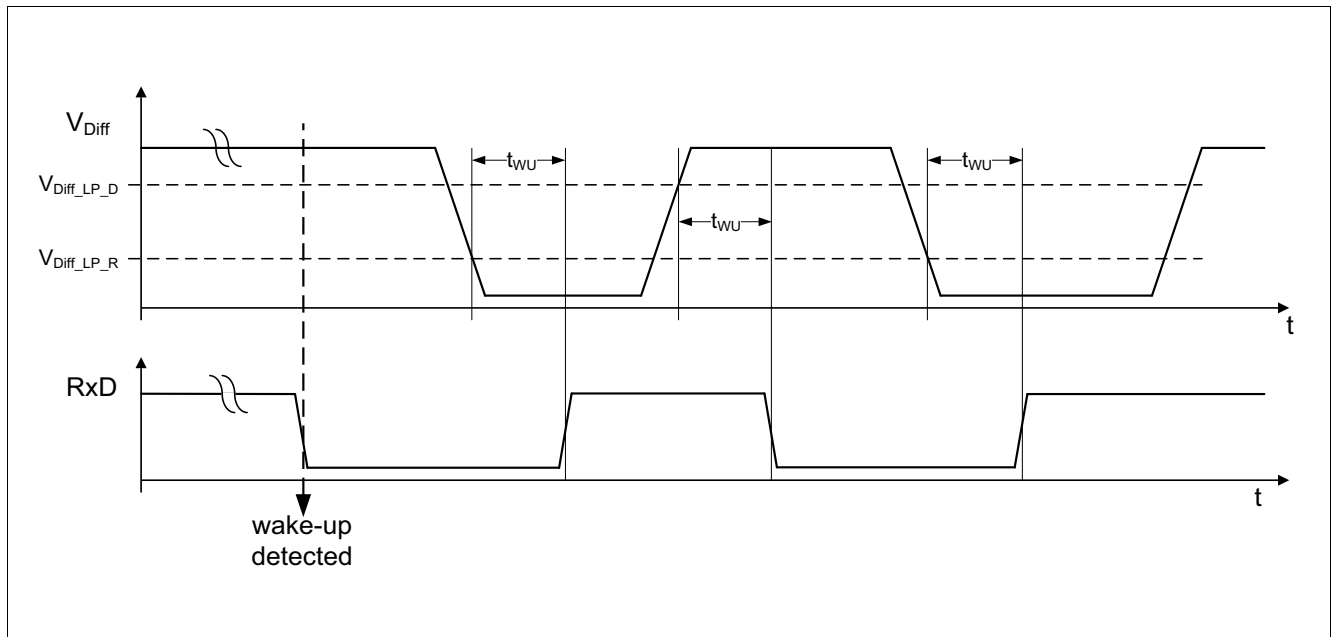

Figure 10 RxD signal after wake-up detection

8 Fail safe functions

8.1 Short circuit protection

The CANH and CANL bus pins are proven to cope with a short circuit fault against GND and against the supply voltages. A current limiting circuit protects the transceiver against damages. If the device is heating up due to a continuous short on the CANH or CANL, the internal overtemperature protection switches off the bus transmitter.

8.2 Unconnected logic pins

All logic input pins have an internal pull-up current source to V_{CC} . In case the V_{CC} supply is activated and the logical pins are open, the TLE9251 enters into the Stand-by mode by default.

8.3 TxD time-out function

The TxD time-out feature protects the CAN bus against permanent blocking in case the logical signal on the TxD pin is continuously “low”. A continuous “low” signal on the TxD pin might have its root cause in a locked-up microcontroller or in a short circuit on the printed circuit board, for example.

In Normal-operating mode, a logical “low” signal on the TxD pin for the time $t > t_{TxD}$ enables the TxD time-out feature and the TLE9251 disables the transmitter (see [Figure 11](#)). The receiver is still active and the data on the bus continues to be monitored by the RxD output pin.

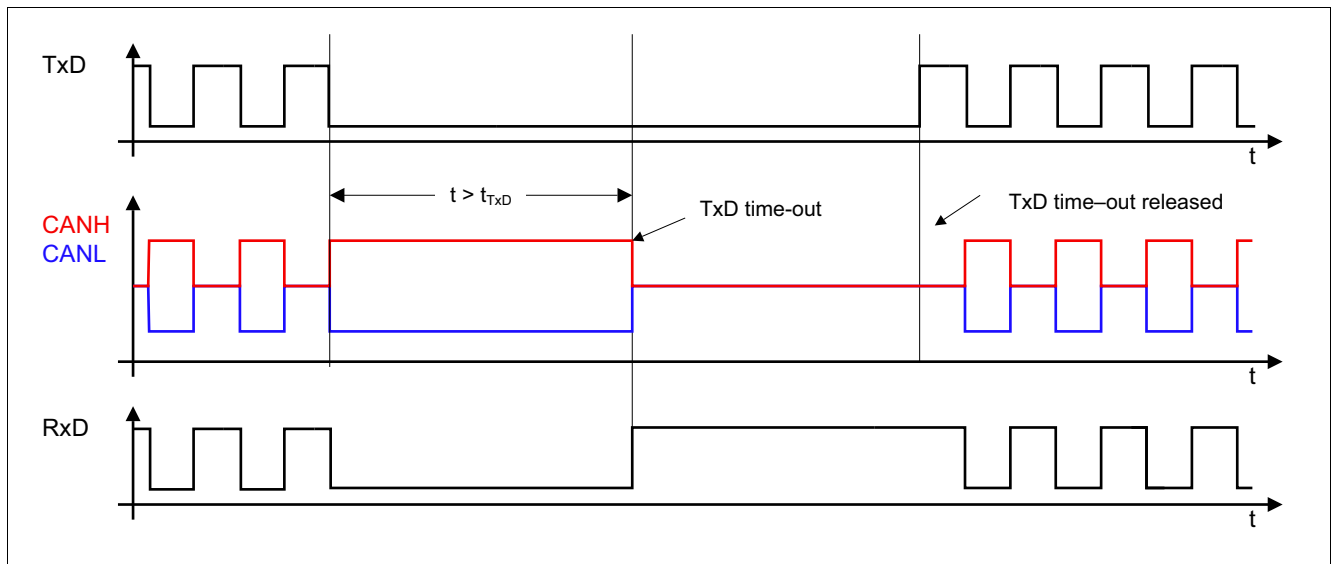

Figure 11 TxD time-out function

[Figure 11](#) illustrates how the transmitter is deactivated and activated again. A permanent “low” signal on the TxD input pin activates the TxD time-out function and deactivates the transmitter. To release the transmitter after a TxD time-out event, the TLE9251 requires a signal change on the TxD input pin from logical “low” to logical “high”.

8.4 Overtemperature protection

The TLE9251 has an integrated overtemperature detection to protect the TLE9251 against thermal overstress of the transmitter. The overtemperature protection is only active in Normal-operating mode. In case of an

Fail safe functions

overtemperature condition, the temperature sensor will disable the transmitter while the transceiver remains in Normal-operating mode. After the device has cooled down the transmitter is activated again (see [Figure 12](#)). A hysteresis is implemented within the temperature sensor.

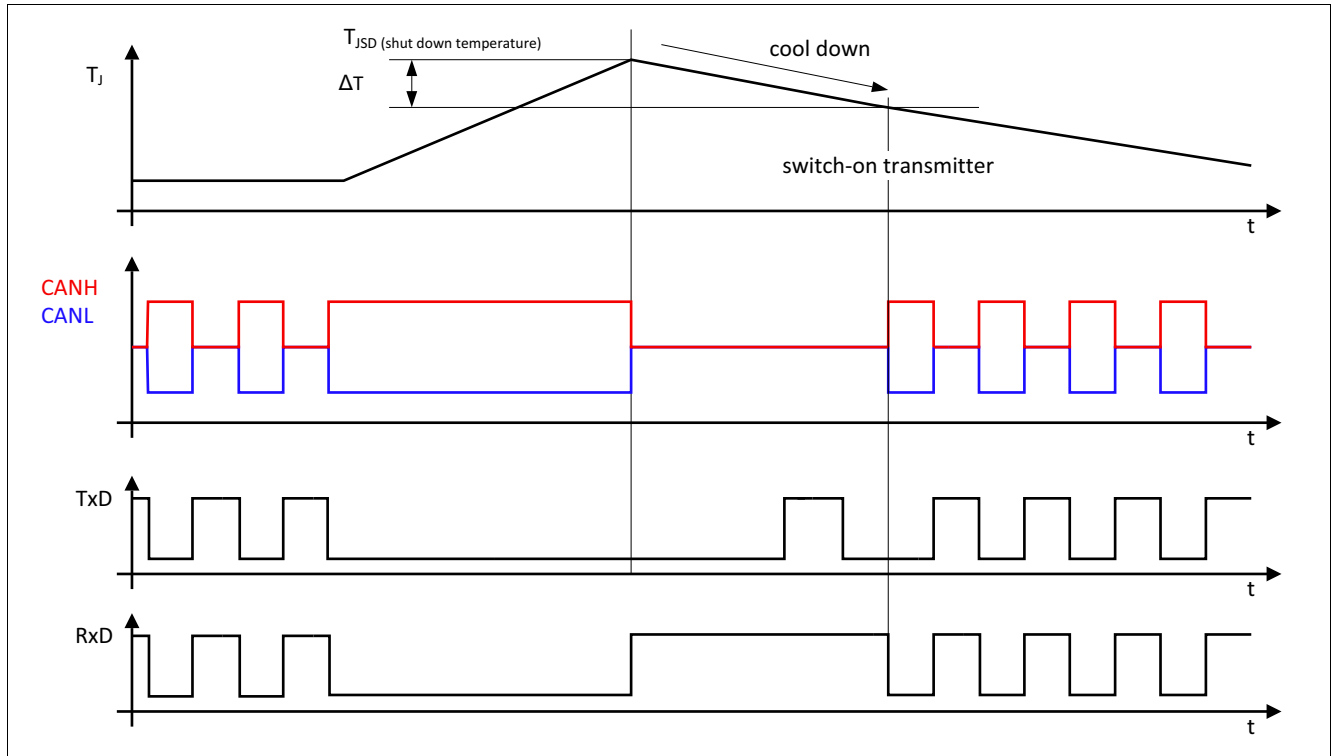

Figure 12 Overtemperature protection

Electrical characteristics

9 Electrical characteristics

9.1 Functional device characteristics

Table 6 Electrical characteristics

4.5 V < V_{CC} < 5.5 V; $R_L = 60 \Omega$; $-40^\circ\text{C} < T_j < 150^\circ\text{C}$; all voltages with respect to ground; positive current flowing into pin; unless otherwise specified.

Parameter	Symbol	Values			Unit	Note or Test Condition	Number
		Min.	Typ.	Max.			
Current Consumption							
Current consumption at V_{CC} Normal-operating, recessive state	I_{CC_R}	–	2	4	mA	$V_{\text{TxD}} = V_{CC}$; $V_{\text{STB}} = 0\text{ V}$;	P_9.1.1
Current consumption at V_{CC} Normal-operating mode, dominant state	I_{CC_D}	–	38	48	mA	$V_{\text{TxD}} = V_{\text{STB}} = 0\text{ V}$;	P_9.1.2
Current consumption at V_{CC} Stand-by mode	$I_{CC(\text{STB})}$	–	7	18	μA	$V_{\text{TxD}} = V_{\text{STB}} = V_{CC}$;	P_9.1.4
Current consumption at V_{CC} Stand-by mode	$I_{CC(\text{STB})_85}$	–	–	13	μA	¹⁾ $V_{\text{TxD}} = V_{\text{STB}} = V_{CC}$; $T_j < 85^\circ\text{C}$; $0\text{ V} < V_{CC} < 5.5\text{ V}$;	P_9.1.6
Supply resets							
V_{CC} undervoltage monitor rising edge	$V_{CC(\text{UV,R})}$	3.8	4.35	4.5	V	–	P_9.1.12
V_{CC} undervoltage monitor falling edge	$V_{CC(\text{UV,F})}$	3.8	4.25	4.5	V	–	P_9.1.13
V_{CC} undervoltage monitor hysteresis	$V_{CC(\text{UV,H})}$	–	100	–	mV	¹⁾	P_9.1.14
V_{CC} power-down threshold	V_{CC_POD}	2.0	2.55	3.0	V	–	P_9.1.92
V_{CC} delay time power-up	t_{PON}	–	–	280	μs	¹⁾ (see Figure 6);	P_9.1.19
V_{CC} delay time power-down	t_{POFF}	–	–	100	μs	¹⁾ (see Figure 6);	P_9.1.20
Receiver output RxD							
“High” level output current	$I_{\text{RxD,H}}$	–	-4	-1	mA	$V_{\text{RxD}} = V_{CC} - 0.4\text{ V}$; $V_{\text{Diff}} < 0.5\text{ V}$;	P_9.1.21
“Low” level output current	$I_{\text{RxD,L}}$	1	4	–	mA	$V_{\text{RxD}} = 0.4\text{ V}$; $V_{\text{Diff}} > 0.9\text{ V}$;	P_9.1.22
Transmission input TxD							
“High” level input voltage threshold	$V_{\text{TxD,H}}$	–	0.5 $\times V_{CC}$	0.7 $\times V_{CC}$	V	recessive state;	P_9.1.26
“Low” level input voltage threshold	$V_{\text{TxD,L}}$	0.3 $\times V_{CC}$	0.4 $\times V_{CC}$	–	V	dominant state;	P_9.1.27
Input hysteresis	$V_{\text{HYS}(\text{TxD})}$	–	200	–	mV	¹⁾	P_9.1.28

Electrical characteristics

Table 6 Electrical characteristics (cont'd)

4.5 V < V_{CC} < 5.5 V; R_L = 60 Ω; -40 °C < T_j < 150 °C; all voltages with respect to ground; positive current flowing into pin; unless otherwise specified.

Parameter	Symbol	Values			Unit	Note or Test Condition	Number
		Min.	Typ.	Max.			
“High” level input current	I _{TxD,H}	-2	-	2	μA	V _{TxD} = V _{CC} ;	P_9.1.29
“Low” level input current	I _{TxD,L}	-200	-	-20	μA	V _{TxD} = 0 V;	P_9.1.30
Input capacitance	C _{TxD}	-	-	10	pF	¹⁾	P_9.1.31
TxD permanent dominant time-out, optional	t _{TxD}	1	-	4	ms	Normal-operating mode;	P_9.1.32

stand-by input STB

“High” level input voltage threshold	V _{STB,H}	-	0.5 × V _{CC}	0.7 × V _{CC}	V	Stand-by mode;	P_9.1.36
“Low” level input voltage threshold	V _{STB,L}	0.3 × V _{CC}	0.4 × V _{CC}	-	V	Normal-operating mode;	P_9.1.37
Input hysteresis	V _{HYS(STB)}	-	200	-	mV	¹⁾	P_9.1.42
Input capacitance	C _(STB)	-	-	10	pF	¹⁾	P_9.1.43

Bus receiver

Differential range dominant Normal-operating mode	V _{Diff_D_Range}	0.9	-	8.0	V	-12 V ≤ V _{CMR} ≤ 12 V;	P_9.1.46
Differential range recessive Normal-operating mode	V _{Diff_R_Range}	-3.0	-	0.5	V	-12 V ≤ V _{CMR} ≤ 12 V;	P_9.1.48
Differential receiver hysteresis Normal-operating mode	V _{Diff,hys}		30		mV	¹⁾	P_9.1.49
Differential range threshold dominant Stand-by mode	V _{Diff_D_STB_Range}	1.15	-	8.0	V	-12 V ≤ V _{CMR} ≤ 12 V;	P_9.1.50
Differential range recessive Stand-by mode	V _{Diff_R_STB_Range}	-3.0	-	0.4	V	-12 V ≤ V _{CMR} ≤ 12 V;	P_9.1.51
Common mode range	CMR	-12	-	12	V	-	P_9.1.52
Single ended internal resistance	R _{CAN_H} , R _{CAN_L}	6	-	50	kΩ	recessive state; -2 V ≤ V _{CANH} ≤ 7 V; -2 V ≤ V _{CANL} ≤ 7 V;	P_9.1.53
Differential internal resistance	R _{Diff}	12	-	100	kΩ	recessive state; -2 V ≤ V _{CANH} ≤ 7 V; -2 V ≤ V _{CANL} ≤ 7 V;	P_9.1.54
Input resistance deviation between CANH and CANL	ΔR _i	-3	-	3	%	¹⁾ recessive state; V _{CANH} = V _{CANL} = 5 V;	P_9.1.55
Input capacitance CANH, CANL versus GND	C _{In}	-	20	40	pF	²⁾ recessive state	P_9.1.56
Differential input capacitance	C _{InDiff}	-	10	20	pF	²⁾ recessive state	P_9.1.57

Bus transmitter

Electrical characteristics

Table 6 Electrical characteristics (cont'd)

4.5 V < V_{CC} < 5.5 V; R_L = 60 Ω; -40 °C < T_j < 150 °C; all voltages with respect to ground; positive current flowing into pin; unless otherwise specified.

Parameter	Symbol	Values			Unit	Note or Test Condition	Number
		Min.	Typ.	Max.			
CANL, CANH recessive output voltage Normal-operating mode	V _{CANL,H}	2.0	2.5	3.0	V	V _{TxD} = V _{CC} ; no load;	P_9.1.58
CANH, CANL recessive output voltage difference Normal-operating mode	V _{Diff_R_NM} = V _{CANH} - V _{CANL}	-50	-	50	mV	V _{TxD} = V _{CC} ; no load;	P_9.1.59
CANL dominant output voltage Normal-operating mode	V _{CANL}	0.5	-	2.25	V	V _{TxD} = 0 V; 50 Ω < R _L < 65 Ω; 4.75 V < V _{CC} < 5.25 V;	P_9.1.60
CANH dominant output voltage Normal-operating mode	V _{CANH}	2.75	-	4.5	V	V _{TxD} = 0 V; 50 Ω < R _L < 65 Ω; 4.75 V < V _{CC} < 5.25 V;	P_9.1.61
Differential voltage dominant Normal-operating mode V _{Diff} = V _{CANH} - V _{CANL}	V _{Diff_D_NM}	1.5	2.0	2.5	V	V _{TxD} = 0 V; 50 Ω < R _L < 65 Ω; 4.75 V < V _{CC} < 5.25 V;	P_9.1.62
Differential voltage dominant extended bus load Normal-operating mode	V _{Diff_EXT_BL}	1.4	2.0	3.3	V	V _{TxD} = 0 V; 45 Ω < R _L < 70 Ω; 4.75 V < V _{CC} < 5.25 V;	P_9.1.63
Differential voltage dominant high extended bus load Normal-operating mode	V _{Diff_HEXT_BL}	1.5	-	5.0	V	V _{TxD} = 0 V; R _L = 2240 Ω; 4.75 V < V _{CC} < 5.25 V; static behavior; ¹⁾	P_9.1.64
CANH, CANL recessive output voltage difference Stand-by mode	V _{Diff_STB}	-0.2	-	0.2	V	no load;	P_9.1.65
CANL, CANH recessive output voltage Stand-by mode	V _{CANL,H}	-0.1	-	0.1	V	no load;	P_9.1.66
Driver symmetry (V _{SYM} = V _{CANH} + V _{CANL})	V _{SYM}	0.9 × V _{CC}	1.0 × V _{CC}	1.1 × V _{CC}	V	^{1) 3)} C ₁ = 4.7 nF;	P_9.1.67
CANL short circuit current	I _{CANLsc}	40	75	115	mA	V _{CANLshort} = 18 V; t < t _{TxD} ; V _{TxD} = 0 V;	P_9.1.68
CANH short circuit current	I _{CANHsc}	-115	-75	-40	mA	V _{CANHshort} = -3 V; t < t _{TxD} ; V _{TxD} = 0 V;	P_9.1.70
Leakage current, CANH	I _{CANH,lk}	-5	-	5	μA	V _{CC} = 0 V; 0 V < V _{CANH} ≤ 5 V; V _{CANH} = V _{CANL} ;	P_9.1.71

Electrical characteristics

Table 6 Electrical characteristics (cont'd)

4.5 V < V_{CC} < 5.5 V; R_L = 60 Ω; -40 °C < T_j < 150 °C; all voltages with respect to ground; positive current flowing into pin; unless otherwise specified.

Parameter	Symbol	Values			Unit	Note or Test Condition	Number
		Min.	Typ.	Max.			
Leakage current, CANL	I _{CANL,lk}	-5	-	5	μA	V _{CC} = 0 V; 0 V < V _{CANL} ≤ 5 V; V _{CANH} = V _{CANL} ;	P_9.1.72
CANH, CANL output voltage difference slope, recessive to dominant	V _{diff_slope_rd}	-	-	70	V/μs	¹⁾ 30 % to 70 % of measured differential bus voltage; C ₂ = 100 pF; R _L = 60 Ω; 4.75 V < V _{CC} < 5.25 V;	P_9.1.190
CANH, CANL output voltage difference slope, dominant to recessive	V _{diff_slope_dr}	-	-	70	V/μs	¹⁾ 70 % to 30 % of measured differential bus voltage; C ₂ = 100 pF; R _L = 60 Ω; 4.75 V < V _{CC} < 5.25 V;	P_9.1.191

Dynamic CAN-transceiver characteristics

Propagation delay TxD-to-RxD	t _{Loop}	80	-	215	ns	C ₁ = 0 pF; C ₂ = 100 pF; C _{RxD} = 15 pF; (see Figure 14)	P_9.1.73
Propagation delay increased load TxD-to-RxD	t _{Loop_150}	80	-	330	ns	¹⁾ C ₁ = 0 pF; C ₂ = 100 pF; C _{RxD} = 15 pF; R _L = 150 Ω;	P_9.1.74

Delay Times

Delay time for mode change	t _{Mode}	-	-	20	μs	¹⁾	P_9.1.79
CAN activity filter time	t _{Filter}	0.5	-	1.8	μs	¹⁾	P_9.1.81
Bus wake-up time-out	t _{Wake}	0.8	-	10	ms	¹⁾	P_9.1.82
Bus wake-up delay time	t _{WU}	-	-	5	μs		P_9.1.83

CAN FD characteristics

Received recessive bit width at 2 MBit/s	t _{Bit(RxD)_2M}	400	500	550	ns	C ₂ = 100 pF; C _{RxD} = 15 pF; t _{Bit} = 500 ns; (see Figure 15);	P_9.1.84
Received recessive bit width at 5 MBit/s	t _{Bit(RxD)_5M}	120	200	220	ns	C ₂ = 100 pF; C _{RxD} = 15 pF; t _{Bit} = 200 ns; (see Figure 15);	P_9.1.85
Transmitted recessive bit width at 2 MBit/s	t _{Bit(Bus)_2M}	435	500	530	ns	C ₂ = 100 pF; C _{RxD} = 15 pF; t _{Bit} = 500 ns; (see Figure 15);	P_9.1.86

Electrical characteristics

Table 6 Electrical characteristics (cont'd)

4.5 V < V_{CC} < 5.5 V; R_L = 60 Ω; -40 °C < T_j < 150 °C; all voltages with respect to ground; positive current flowing into pin; unless otherwise specified.

Parameter	Symbol	Values			Unit	Note or Test Condition	Number
		Min.	Typ.	Max.			
Transmitted recessive bit width at 5 MBit/s	$t_{\text{Bit(Bus)}_5\text{M}}$	155	200	210	ns	C ₂ = 100 pF; C _{RxD} = 15 pF; t _{Bit} = 200 ns; (see Figure 15);	P_9.1.87
Receiver timing symmetry at 2 MBit/s $\Delta t_{\text{Rec}_2\text{M}} = t_{\text{Bit(RxD)}_2\text{M}} - t_{\text{Bit(Bus)}_2\text{M}}$	$\Delta t_{\text{Rec}_2\text{M}}$	-65	-	40	ns	C ₂ = 100 pF; C _{RxD} = 15 pF; t _{Bit} = 500 ns; (see Figure 15);	P_9.1.88
Receiver timing symmetry at 5 MBit/s $\Delta t_{\text{Rec}_5\text{M}} = t_{\text{Bit(RxD)}_5\text{M}} - t_{\text{Bit(Bus)}_5\text{M}}$	$\Delta t_{\text{Rec}_5\text{M}}$	-45	-	15	ns	C ₂ = 100 pF; C _{RxD} = 15 pF; t _{Bit} = 200 ns; (see Figure 15);	P_9.1.89

- 1) Not subject to production test, specified by design
- 2) Not subject to production test, specified by design, S2P-Method; f = 10 MHz
- 3) VSYM shall be observed during dominant and recessive state and also during the transition from dominant to recessive and vice versa, while TxD is stimulated by a square wave signal with a frequency of 1 MHz.

Electrical characteristics

9.2 Diagrams

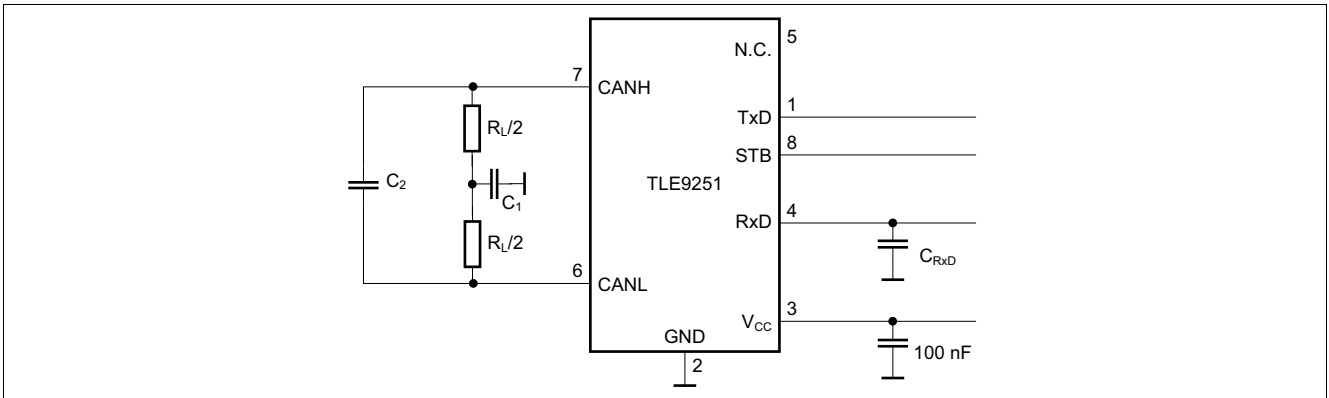

Figure 13 Test circuit for dynamic characteristics

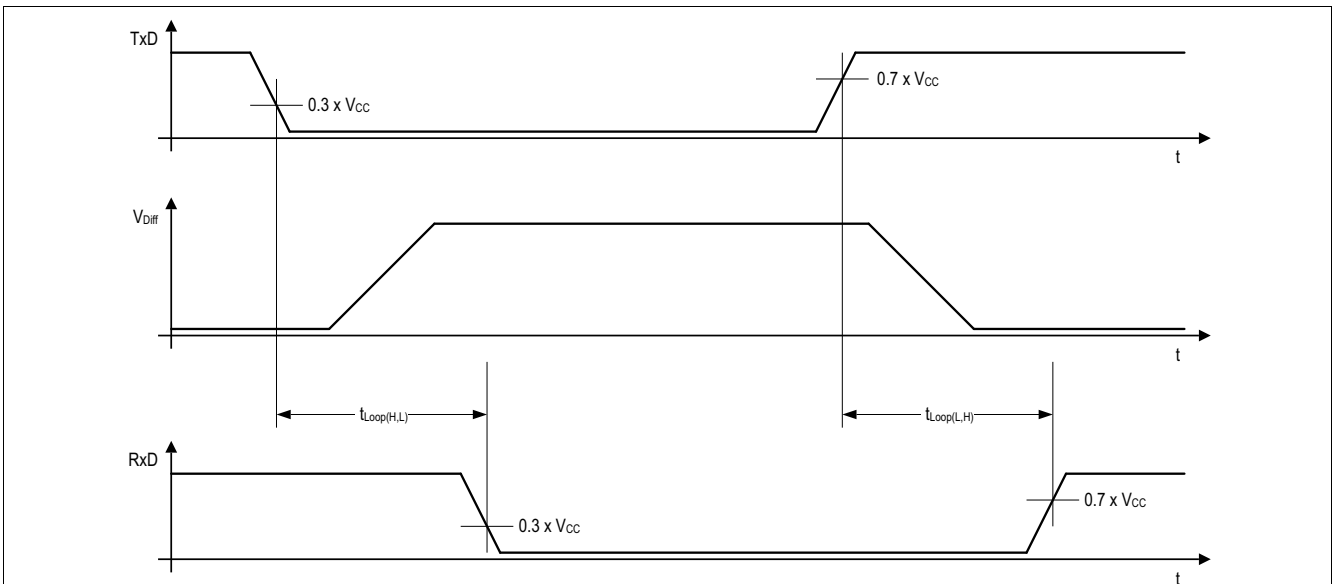

Figure 14 Timing diagrams for dynamic characteristics

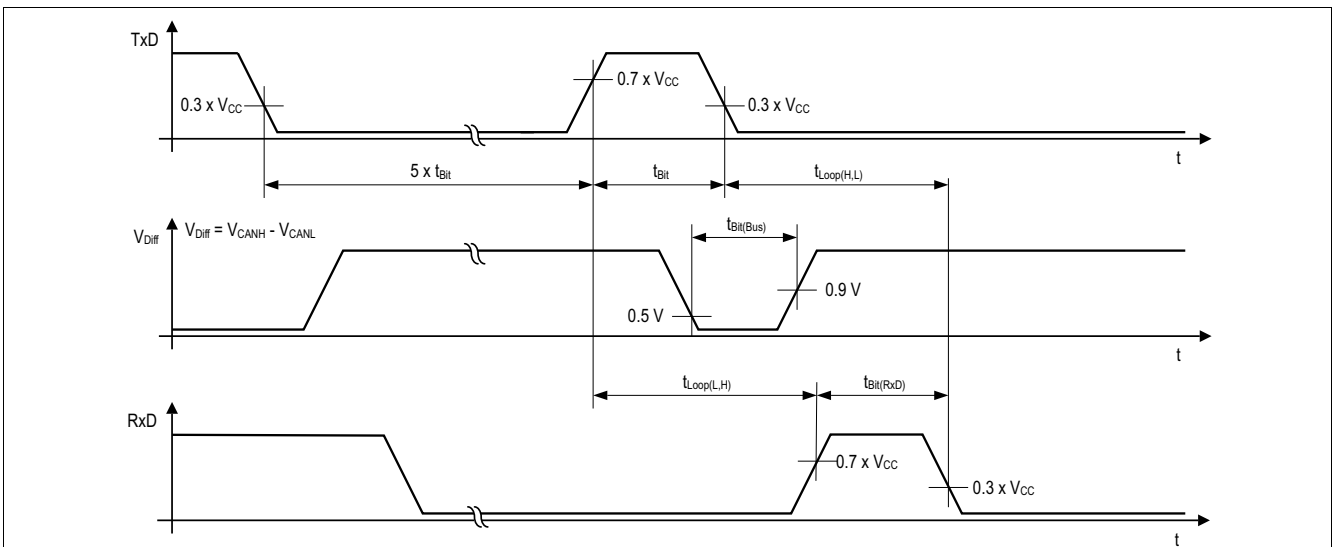

Figure 15 Recessive bit time for five dominant bits followed by one recessive bit

Application information

10 Application information

10.1 ESD robustness according to IEC61000-4-2

Tests for ESD robustness according to IEC61000-4-2 “Gun test” (150 pF, 330 Ω) have been performed. The results and test conditions are available in a separate test report.

Table 7 ESD robustness according to IEC61000-4-2

Performed Test	Result	Unit	Remarks
Electrostatic discharge voltage at pin CANH and CANL versus GND	≥ +11	kV	¹⁾ Positive pulse
Electrostatic discharge voltage at pin CANH and CANL versus GND	≤ -11	kV	¹⁾ Negative pulse

1) Not subject to production test. ESD susceptibility “ESD GUN” according to GIFT / ICT paper: “EMC Evaluation of CAN Transceivers, version IEC TS62228”, section 4.3. (DIN EN61000-4-2)
Tested by external test facility (IBEE Zwickau, EMC test report Nr. 01-07-2017 and Nr. 06-08-17)

10.2 Application example

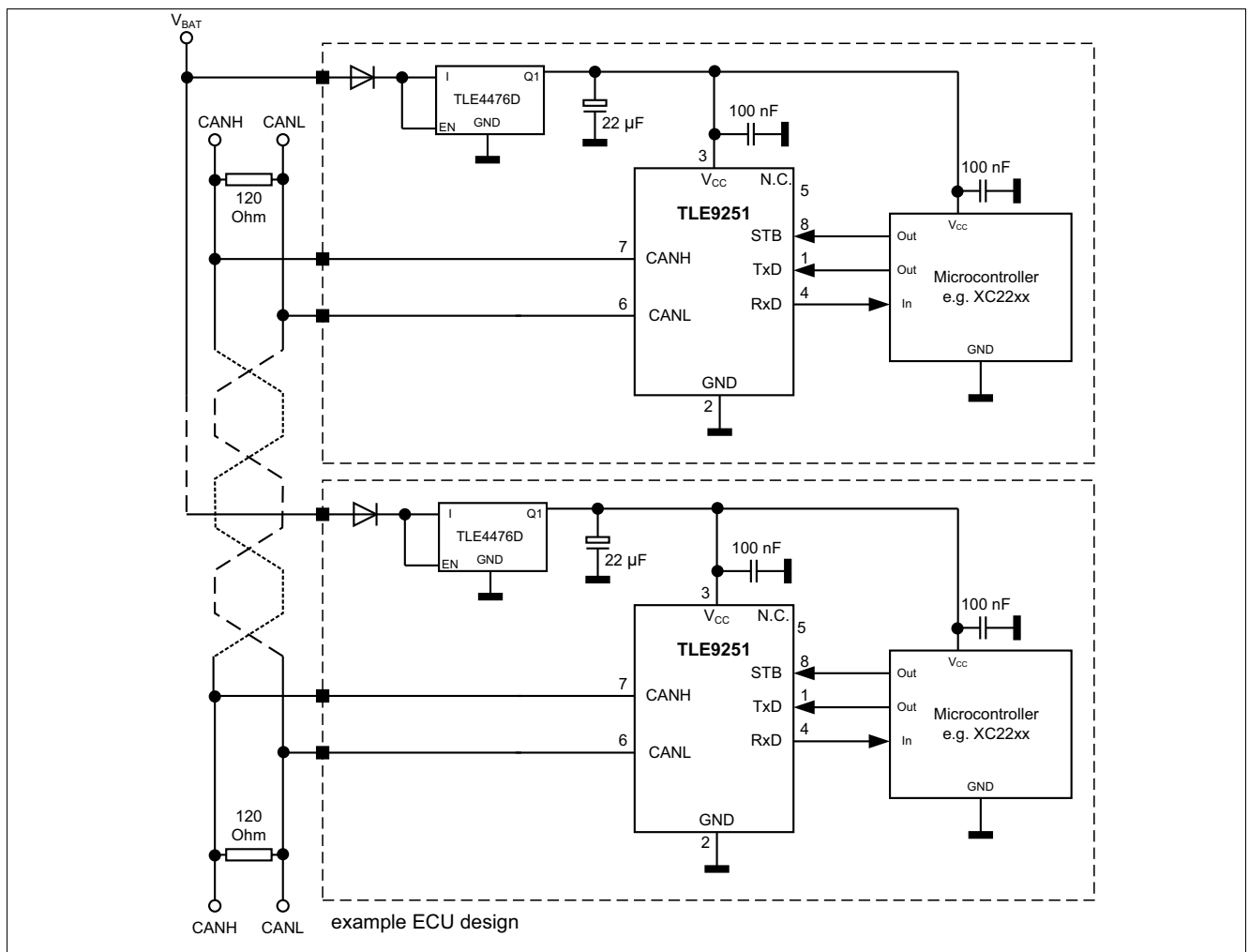

Figure 16 Application circuit

Application information

10.3 Further application information

- For further information you may visit: <http://www.infineon.com/automotive-transceiver>

Package outline

11 Package outline

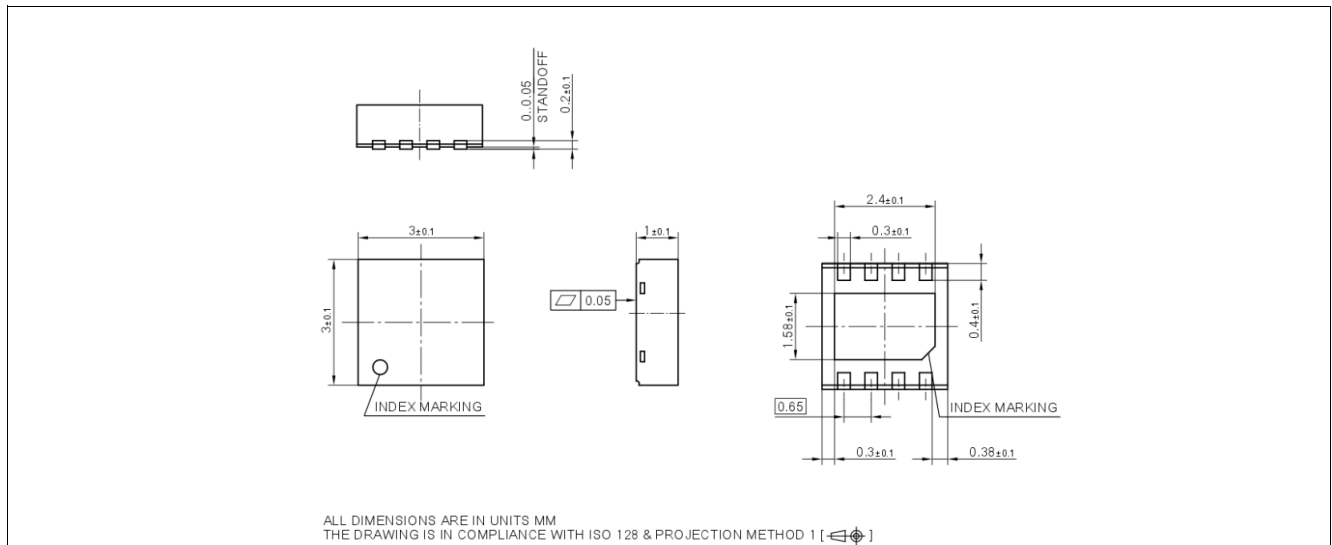

Figure 17 PG-TSON-8 (Plastic Thin Small Outline Nonleaded)

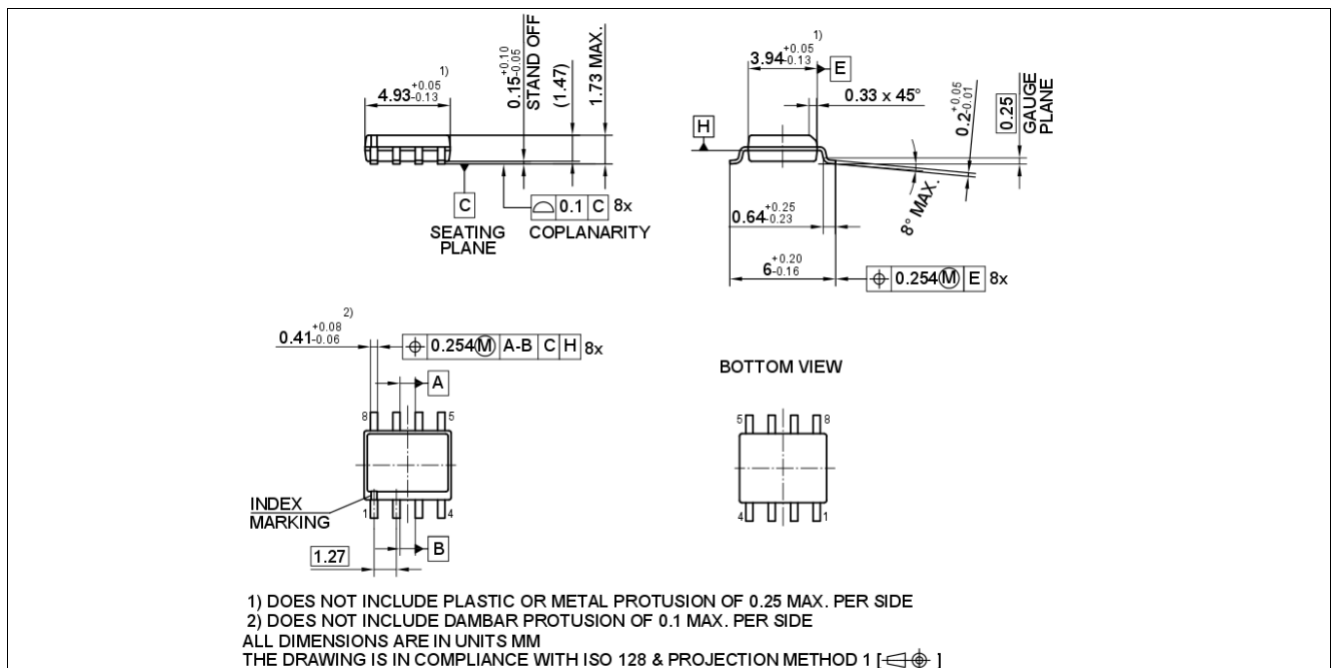

Figure 18 PG-DSO-8 (Plastic Dual Small Outline)

Green product (RoHS compliant)

To meet the world-wide customer requirements for environmentally friendly products and to be compliant with government regulations the device is available as a green product. Green products are RoHS compliant (i.e. Pb-free finish on leads and suitable for Pb-free soldering according to IPC/JEDEC J-STD-020).

For further information on alternative packages, please visit our website:
<http://www.infineon.com/packages>.

Dimensions in mm

Revision history

12 Revision history

Revision	Date	Changes
1.11	2019-09-19	<p>Datasheet updated:</p> <ul style="list-style-type: none"> • Editorial changes • Updated bus transmitter table <ul style="list-style-type: none"> – added P_9.1.190 and P_9.1.191 (no product change) – tightened P_9.1.59 and P_9.1.62 – tightened P_9.1.56 and P_9.1.57 by additional footnote • Updated dynamic CAN-transceiver characteristics table <ul style="list-style-type: none"> – tightened P_9.1.73
1.1	2018-05-23	<p>Datasheet updated:</p> <ul style="list-style-type: none"> • I_{CC_D} max. lowered from 60mA to 48mA (see P_9.1.2) • I_{CC_STB} max. lowered from 20μA to 18μA (see P_9.1.4) • Extended temperature condition $T_j < 150^\circ\text{C}$ (see P_9.1.4) • Introduced new Stand-by Mode current consumption for $V_{CC} t < 85^\circ\text{C}$: max. 13μA (see P_9.1.6) • Increased HBM robustness to +/-10kV (see P_8.1.11) • Updated Figure 14. Removed unspecified parameters $t_{d(L),T}$, $t_{d(L),R}$, $t_{d(H),T}$, $t_{d(H),R}$. • Editorial Changes
1.0	2017-09-14	Datasheet created

Trademarks

All referenced product or service names and trademarks are the property of their respective owners.

Edition 2019-09-19

Published by

Infineon Technologies AG

81726 Munich, Germany

© 2019 Infineon Technologies AG.

All Rights Reserved.

Do you have a question about any aspect of this document?

Email: erratum@infineon.com

Document reference

Z8F62138700

IMPORTANT NOTICE

The information given in this document shall in no event be regarded as a guarantee of conditions or characteristics ("Beschaffheitsgarantie").

With respect to any examples, hints or any typical values stated herein and/or any information regarding the application of the product, Infineon Technologies hereby disclaims any and all warranties and liabilities of any kind, including without limitation warranties of non-infringement of intellectual property rights of any third party.

In addition, any information given in this document is subject to customer's compliance with its obligations stated in this document and any applicable legal requirements, norms and standards concerning customer's products and any use of the product of Infineon Technologies in customer's applications.

The data contained in this document is exclusively intended for technically trained staff. It is the responsibility of customer's technical departments to evaluate the suitability of the product for the intended application and the completeness of the product information given in this document with respect to such application.

For further information on technology, delivery terms and conditions and prices, please contact the nearest Infineon Technologies Office (www.infineon.com).

WARNINGS

Due to technical requirements products may contain dangerous substances. For information on the types in question please contact your nearest Infineon Technologies office.

Except as otherwise explicitly approved by Infineon Technologies in a written document signed by authorized representatives of Infineon Technologies, Infineon Technologies' products may not be used in any applications where a failure of the product or any consequences of the use thereof can reasonably be expected to result in personal injury.